

YUKON SERIES

INDOOR UNITS ALL-IN-ONE

MSH-190TB/3
MSH-190TB-3/9
MSH-240TB/3
MSH-240TB-3/9

S-THERM

 **SINCLAIR**
HEAT PUMPS

„ORIGINAL INSTRUCTIONS“

IMPORTANT NOTE:

Read this manual carefully before installing or operating your new heat pump.
Make sure to save this manual for future reference.

CONTENTS

1	SAFETY PRECAUTIONS	02
2	ACCESSORIES	08
	• 2.1 Unpacking	08
	• 2.2 Remove the wooden base	09
3	INSTALLATION SITE	09
4	INSTALLATION	10
	• 4.1 Dimensions of the unit	10
	• 4.2 Installation requirements	11
	• 4.3 Servicing space requirements	11
	• 4.4 Mounting the indoor unit	11
5	CONNECTING THE REFRIGERANT PIPING	12
6	CONNECTING THE WATER PIPING	13
	• 6.1 Connecting the space heating(cooling) water piping	13
	• 6.2 Connecting the domestic water piping	13
	• 6.3 Connecting the recirculation water piping	14
	• 6.4 Connecting the drainage hose to the indoor unit	15
	• 6.5 Connecting the solar circulation piping (if needed)	15
	• 6.6 Water piping insulation	15
	• 6.7 Water circuit anti-freeze protection	15
	• 6.8 Filling water	17
	• 6.9 Typical Applications	18
7	FIELD WIRING	20
	• 7.1 Precautions on electrical wiring work	20
	• 7.2 Precautions on wiring of power supply	20
	• 7.3 Safety device requirements	21
	• 7.4 Before connecting the wiring	21
	• 7.5 Connecting the main power supply	22
	• 7.6 Connecting for other components	23
8	START-UP AND CONFIGURATION	29
	• 8.1 Initial start-up at low outdoor ambient temperature	29
	• 8.2 Pre-operation checks	29
	• 8.3 Field settings	30
	• 8.4 About FOR SERVICEMAN	31

9 TEST RUN AND FINAL CHECKS	37
• 9.1 Final checks	37
• 9.2 Test run operation (manually)	37
10 MAINTENANCE AND SERVICE	37
11 TECHNICAL SPECIFICATIONS	38
12 ERROR CODE	44
ANNEX A	47

1 SAFETY PRECAUTIONS

The precautions listed here are divided into the following types. They are quite important, so be sure to follow them carefully. Read these instructions carefully before installation. Keep this manual in a handy for future reference.

Meanings of DANGER, WARNING, CAUTION and NOTE symbols.

DANGER

Indicates an imminently hazardous situation which if not avoided, will result in death or serious injury.

WARNING

Indicates a potentially hazardous situation which if not avoided, could result in death or serious injury.

CAUTION

Indicates a potentially hazardous situation which if not avoided, may result in minor or moderate injury. It is also used to alert against unsafe practices.

NOTE

Indicates situations that could only result in accidental equipment or property damage.

WARNING

- Improper installation of equipment or accessories may result in electric shock, short-circuit, leakage, fire or other damage to the equipment. Be sure to only use accessories made by the supplier, which are specifically designed for the equipment and make sure to get installation done by a professional.
- All the activities described in this manual must be carried out by a licensed technician. Be sure to wear adequate personal protection equipment such as gloves and safety glasses while installing the unit or carrying out maintenance activities.
- This appliance which connect 1-phase 6KW backup heater can be connected only to a supply with system impedance no more than 0.3079Ω. In case necessary, please consult your supply authority for system impedance information.



Caution: Risk of fire/
flammable materials

WARNING

Servicing shall only be performed as recommended by the equipment manufacturer. Maintenance and repair requiring the assistance of other skilled personnel shall be carried out under the supervision of the person competent in the use of flammable refrigerants.

Special requirements for R32

WARNING

- Refrigerant leakage and open flame are not allowed.
- Be aware that the R32 refrigerant does NOT contain an odour.

WARNING

The appliance shall be stored so as to prevent mechanical damage and in a well-ventilated room without continuously operating ignition sources (example: open flames, an operating gas appliance) and have a room size as specified below.

NOTE

- Do NOT re-use joints which have been used already.
- Joints made in installation among parts of refrigerant system shall be accessible for maintenance purposes.

WARNING

Make sure installation, servicing, maintenance and repair comply with instructions and with applicable legislation (for example national gas regulation) and are executed only by authorised persons.

NOTE

- Pipework should be protected from physical damage.
- Installation of pipework should be kept to a minimum.

If the total refrigerant charged in the system is ≤ 1.842 kg, there are no additional minimum floor area requirements.

If the total refrigerant charged in the system is > 1.842 kg, you need to comply with additional minimum floor area requirements as described in the following flow chart. The flow chart uses the following tables: "Table 1-Maximum refrigerant charge allowed in a room: indoor unit" on page 5, "Table 2-Minimum floor area: indoor unit" on page 5 and "Table 3-Minimum venting opening area for natural ventilation: indoor unit" on page 5.

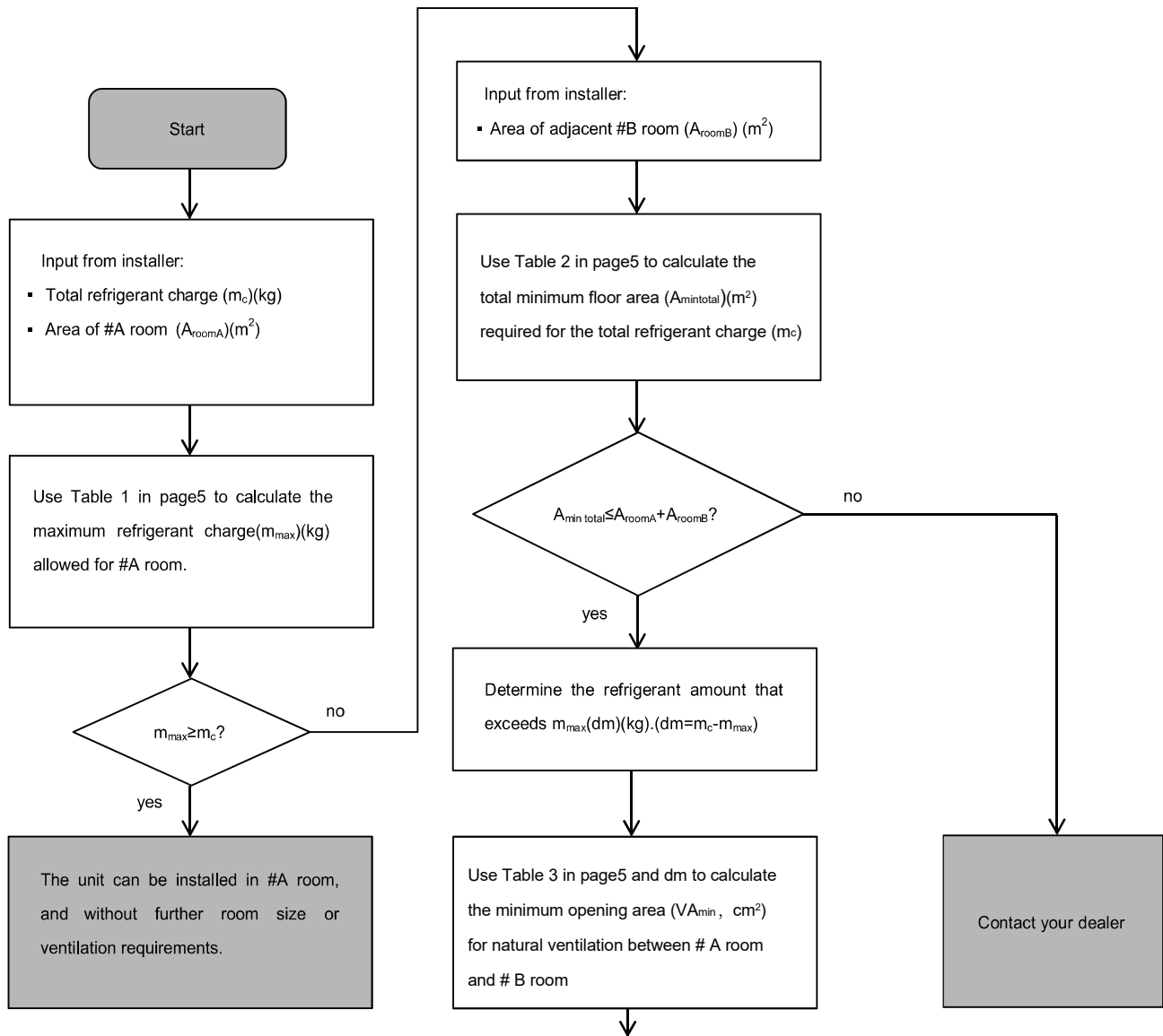

Unit can be installed at #A room if:

- 2 ventilation openings (permanently open) are provided between #A room and #B room, one is in the top and the other is in the bottom.
- Bottom opening: The bottom opening must meet the minimum area requirements (VA_{min}). It must be as close as possible to the floor. If the ventilation opening starts from the floor, the height must be $\geq 20\text{mm}$. The bottom of the opening must be situated $\leq 100\text{mm}$ from the floor.
- The area of the top opening must be larger than or equal to the bottom opening.
- The bottom of the top opening must be situated at least 1.8 m above the top of the bottom opening.
- Ventilation openings to the outside are NOT considered suitable ventilation openings (the user can block them when it is cold).

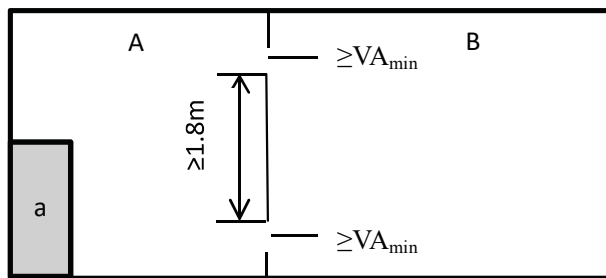

a Indoor unit

#A Room where the indoor unit is installed.

#B Room adjacent to #A room.

The area of A plus B has to be greater than or equal to 6.9 m².

Table 1-Maximum refrigerant charge allowed in a room:indoor unit

$A_{room}(m^2)$	Maximum refrigerant charge in a room(m_{max})(kg)	
	H=1230mm(100/190)	H=1500mm(100/240,160/240)
6.9	1.85	1.85
7.0	1.87	1.93
8.0	1.98	2.01
9.0	2.13	2.10
10.0	2.23	2.19
11.0	2.34	2.27
12.0	2.44	2.34
		8.0
		2.44

Table 2-Minimum floor area:indoor unit

$m_c(kg)$	Minimum floor area(m^2)	
	H=1230mm(100/190)	H=1500mm(100/240,160/240)
1.85	6.90	4.70
1.90	7.31	4.92
1.95	7.70	5.18
2.00	8.10	5.45
2.05	8.51	5.72
2.10	8.93	6.01
2.15	9.36	6.30
2.20	9.80	6.59
2.25	10.3	6.89
2.30	10.7	7.20
2.35	11.2	7.52
2.40	11.7	7.84
2.45	12.2	8.10

Table 3-Minimum venting opening area for natural ventilation: indoor unit

m_c	m_{max}	$dm=m_c-m_{max}(kg)$	Minimum venting opening area(cm^2)	
			H=1230mm(100/190)	H=1500mm(100/240,160/240)
2.41	0.3	2.11	375	290
2.41	0.5	1.91	350	280
2.41	0.7	1.71	330	268
2.41	0.9	1.51	315	258
2.41	1.1	1.31	302	247
2.41	1.3	1.11	278	228
2.41	1.5	0.91	245	200
2.41	1.7	0.71	203	167
2.41	1.9	0.51	154	126
2.41	2.1	0.31	98	80

NOTE

- The value of "installation height(H)" is the distance from the lowest point of the refrigerant pipe of indoor unit to the ground .

DANGER

- Before touching electric terminal parts, turn off power switch.
- When service panels are removed, live parts can be easily touched by accident.
- Never leave the unit unattended during installation or servicing when the service panel is removed.
- Do not touch water pipes during and immediately after operation as the pipes may be hot and could burn your hands. To avoid injury, give the piping time to return to normal temperature or be sure to wear protective gloves if you must touch them.
- Do not touch any switch with wet fingers. Touching a switch with wet fingers can cause electrical shock.
- Before touching electrical parts, turn off all applicable power to the unit.

WARNING

- Tear apart and throw away plastic packaging bags so that children will not play with them. Children playing with plastic bags face danger of death by suffocation.
- Safely dispose of packing materials such as nails and other metal or wood parts that could cause injuries.
- Ask your dealer or qualified personnel to perform installation work in accordance with this manual. Do not install the unit by yourself. Improper installation could result in water leakage, electric shocks or fire.
- Be sure to use only specified accessories and parts for installation work. Failure to use specified parts may result in water leakage, electric shocks, fire or the unit falling from its mount.
- Install the unit on a foundation that can withstand its weight. Insufficient physical strength may cause the equipment to fall and possible injury.
- Perform specified installation work with full consideration of strong wind, hurricanes or earthquakes. Improper installation work may result in accidents due to equipment falling.
- Make certain that all electrical work is carried out by qualified personnel according to the local laws and regulations and this manual using a separate circuit. Insufficient capacity of the power supply circuit or improper electrical construction may lead to electric shocks or fire.
- Be sure to install a ground fault circuit interrupter according to local laws and regulations. Failure to install a ground fault circuit interrupter may cause electric shocks and fire.
- Make sure all wiring is secure. Use the specified wires and ensure that terminal connections or wires are protected from water and other adverse external forces. Incomplete connection or affixing may cause a fire.
- When wiring the power supply, form the wires so that the front panel can be securely fastened. If the front panel is not in place there could be overheating of the terminals, electric shocks or fire.
- After completing the installation work, make sure that there is no refrigerant leakage.
- Never directly touch any leaking refrigerant as it could cause severe frostbite. Do not touch the refrigerant pipes during and immediately after operation as the refrigerant pipes may be hot or cold, depending on the condition of the refrigerant flowing through the refrigerant piping, compressor and other refrigerant cycle parts. Burns or frostbite are possible if you touch the refrigerant pipes. To avoid injury, give the pipes time to return to normal temperature or if you must touch them, be sure to wear protective gloves.
- Do not touch the internal parts (pump, backup heater, etc.) during and immediately after operation. Touching the internal parts can cause burns. To avoid injury, give the internal parts time to return to normal temperature or if you must touch them, be sure to wear protective gloves.

CAUTION

- Ground the unit.
- Grounding resistance should be according to local laws and regulations.
- Do not connect the ground wire to gas or water pipes, lightning conductors or telephone ground wires.
- Incomplete grounding may cause electric shocks.
 - Gas pipes: Fire or an explosion might occur if the gas leaks.
 - Water pipes: Hard vinyl tubes are not effective grounds.
 - Lightning conductors or telephone ground wires: Electrical threshold may rise abnormally if struck by a lightning bolt.

CAUTION

- Install the power wire at least 3 feet (1 meter) away from televisions or radios to prevent interference or noise. (Depending on the radio waves, a distance of 3 feet (1 meter) may not be sufficient to eliminate the noise.)
- Do not wash the unit. This may cause electric shocks or fire. The appliance must be installed in accordance with national wiring regulations. If the supply cord is damaged, it must be replaced by the manufacturer, its service agent or similarly qualified persons in order to avoid a hazard.
- Do not install the unit in the following places:
 - Where there is mist of mineral oil, oil spray or vapors. Plastic parts may deteriorate, and cause them to come loose or water to leak.
 - Where corrosive gases (such as sulphurous acid gas) are produced. Where corrosion of copper pipes or soldered parts may cause refrigerant to leak.
 - Where there is machinery which emits electromagnetic waves. Electromagnetic waves can disturb the control system and cause equipment malfunction.
 - Where flammable gases may leak, where carbon fiber or ignitable dust is suspended in the air or where volatile flammables such as paint thinner or gasoline are handled. These types of gases might cause a fire.
 - Where the air contains high levels of salt such as near the ocean.
 - Where voltage fluctuates a lot, such as in factories.
 - In vehicles or vessels.
 - Where acidic or alkaline vapors are present.
- This appliance can be used by children 8 years old and above and persons with reduced physical, sensory or mental capabilities or lack of experience and knowledge if they are supervised or given instruction on using the unit in a safe manner and understand the hazards involved. Children should not play with the unit. Cleaning and user maintenance should not be done by children without supervision.

Children should be supervised to ensure that they do not play with the appliance.
- If the supply cord is damaged, it must be replaced by the manufacturer or its service agent or a similarly qualified person.
- DISPOSAL: Do not dispose this product as unsorted municipal waste. Collection of such waste separately for special treatment is necessary. Do not dispose of electrical appliances as municipal waste, use separate collection facilities. Contact your local government for information regarding the collection systems available. If electrical appliances are disposed of in landfills or dumps, hazardous substance can leak into the groundwater and get into the food chain, damaging your health and well-being.
- The wiring must be performed by professional technicians in accordance with national wiring regulation and this circuit diagram. An all-pole disconnection device which has at least 3mm separation distance in all pole and a residual current device (RCD) with the rating not exceeding 30mA shall be incorporated in the fixed wiring according to the national rule.
- Confirm the safety of the installation area (walls, floors, etc.) without hidden dangers such as water, electricity, and gas before wiring/pipes.
- Before installation , check whether the user's power supply meets the electrical installation requirements of unit (including reliable grounding , leakage , and wire diameter electrical load, etc.). If the electrical installation requirements of the product are not met, the installation of the product is prohibited until the product is rectified.

Product installation should be fixed firmly, Take reinforcement measures, when necessary.

NOTE

- About Fluorinated Gases
 - This air-conditioning unit contains fluorinated gases. For specific information on the type of gas and the amount, please refer to the relevant label on the unit itself. Compliance with national gas regulations shall be observed.
 - Installation, service, maintenance and repair of this unit must be performed by a certified technician.
 - Product uninstallation and recycling must be performed by a certified technician.
 - If the system has a leak-detection system installed, it must be checked for leaks at least every 12 months. When the unit is checked for leaks, proper record-keeping of all checks is strongly recommended.

2 ACCESSORIES

2.1 Unpacking

Removing the package

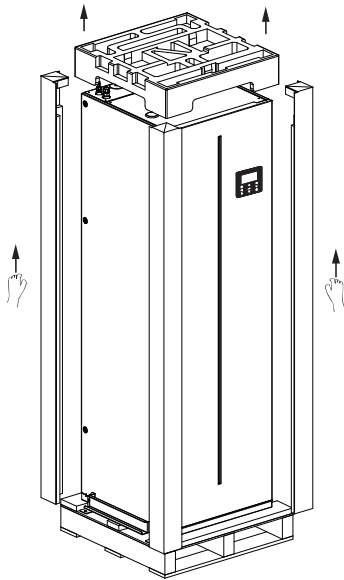

Fig.2-1

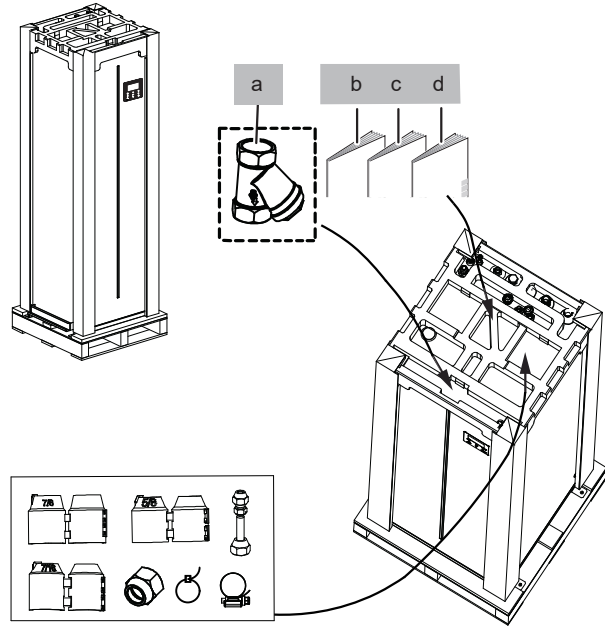

Fig.2-2

Installation Fittings					Installation Fittings				
Name	Shape	Quantity			Name	Shape	Quantity		
		100/190	100/240	160/240			100-190	100-240	160-240
Installation and owner's manual(this book)		1	1	1	M9 Copper Nut		1	1	1
Operation manual		1	1	1	M16 Copper Nut		1	1	1
M16 Copper Nut Tamper Cap		1	1	1	Y-shape filter		1	1	1
M9 Copper Nut Tamper Cap		1	1	1	Operation manual (Wire controller)		1	1	1
M6 Copper Nut Tamper Cap		1	1	1	Transfer 9.52-6.35		1	1	1
					Belt L200		2	2	2
					Throat bander		1	1	1

2.2 Remove the wooden base

- Remove the 4 screws of the wooden base (Refer to Fig.2-3).
- Four people hold the sheet metal lifting machine, one of them pull the wooden base (Refer to Fig.2-4).
- Remove the 8 screws of the sheet metal and remove the sheet metal (Refer to Fig.2-5).
- Take carefully when lifting machine and pull the wooden.
- Care should be taken when transporting the heat pump unit that the casing is not damaged by impact. Do not remove the protective packaging unit heat pump unit has reached its final location. This will help protect the structure and control panel. The heat pump unit can be transported ONLY vertically.
- Be careful with the Installation and Operation manual and with the factory-supplied accessories box located at the top of the unit.
- Four people are required when lifting because of the heavy weight of the unit.

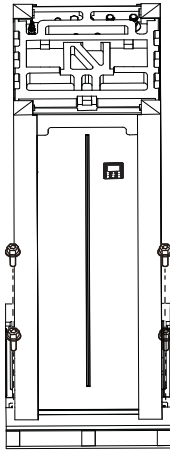

Fig.2-3

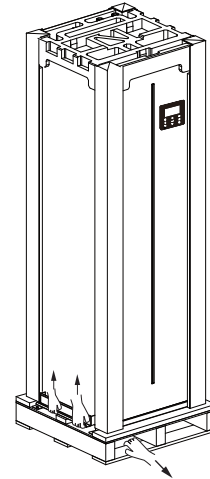

Fig.2-4

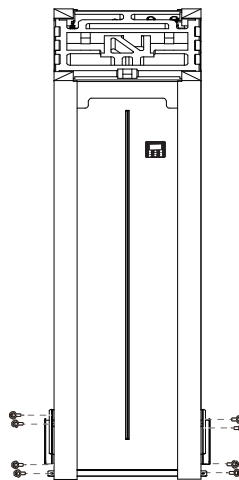

Fig.2-5

3 INSTALLATION SITE

WARNING

- Do not install the IDU near a bedroom;
- Suggest install it in a garage, utility room, corridor, basement, or laundry room;
- Be sure to adopt adequate measures to prevent the unit from being used as a shelter by small animals.
- Small animals making contact with electrical parts can cause malfunction, smoke or fire. Please instruct the customer to keep the area around the unit clean.
- The equipment is not intended for use in a potentially explosive atmosphere.
- Please connect the top pipe or fill the water tank immediately after removing the wooden frame, so as not to cause the machine to tip over.

- Select an installation site where the following conditions are satisfied and one that meets with your customer's approval.
 - Safe places which can bear the unit's weight and where the unit can be installed at an even level.
 - Places where there is no possibility of flammable gas or product leak.
 - The equipment is not intended for use in a potentially explosive atmosphere.
 - Places where servicing space can be well ensured.
 - Places where the units' piping and wiring lengths come within the allowable ranges.
 - Places where water leaking from the unit cannot cause damage to the location (e.g. in case of a blocked drain pipe).
 - Do not install the unit in places often used as a work space. In case of construction work (e.g. grinding etc.) where a lot of dust is created, the unit must be covered.
 - Do not place any object or equipment on top of the unit (top plate)
 - Do not climb, sit or stand on top of the unit.
 - Be sure that sufficient precautions are taken in case of refrigerant leakage according to relevant local laws and regulations.
 - Don't install the unit near the sea or where there is corrosion gas.
- When installing the unit in a place exposed to strong wind, pay special attention to the following.
In normal condition, refer to the figures below for installation of the unit:

CAUTION

The indoor unit should be installed in an indoor water proof place.

The indoor unit is to be floor mounted in an indoor location that meets the following requirements:

- The installation location is frost-free.
- The space around the unit is adequate for servicing (Refer to Fig.4-2).
- There is a provision for condensate drain and pressure relief valve blow-off.

CAUTION

When the unit is running in the cooling mode, condensate may drop from the water inlet and water outlet pipes. Please make sure the dropping condensate will not result in damage of your furniture and other devices.

4 INSTALLATION

4.1 Dimensions of the unit:

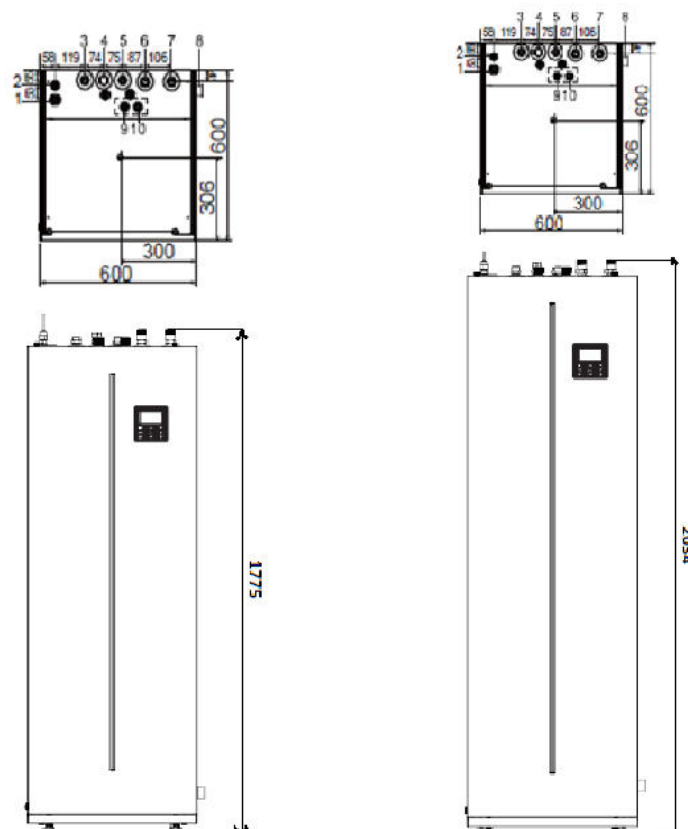

Obr.4-1:

unit:mm

NO.	NAME	NO.	NAME
1	Refrigerant gas connection 5/8"-14UNF	6	Space heating (cooling) water inlet .R1"
2	Refrigerant liquid connection 3/8" -14 UNF	7	Space heating (cooling) water outlet .R1"
3	Domestic hot water outlet R3/4"	8	Drainage Ø 25
4	Domestic hot water recirculation water inlet (Plugged by the nut).	9	Solar circulation outlet (customized)
5	Domestic cold water inlet	10	Solar circulation inlet (customized)

- The content in the dotted line area is for customized.

4.2 Installation requirements

- The indoor unit is packed by the carton cap and corner.
- At delivery, the unit must be checked and any damage must be reported immediately to the carrier claims agent.
- Check if all indoor unit accessories are enclosed.
- Bring the unit as close as possible to the final installation position in its original package in order to prevent damage during transport.
- When the water tank is free of water, the maximum net weight of indoor unit with water tank shall reach about 158Kg, which needs to be lifted by special equipment.

4.3 Servicing space requirements

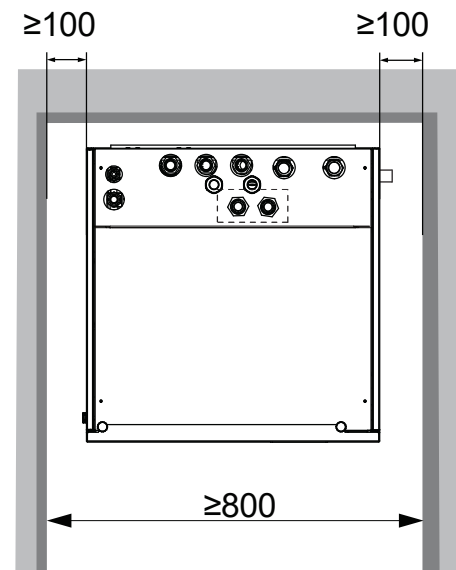
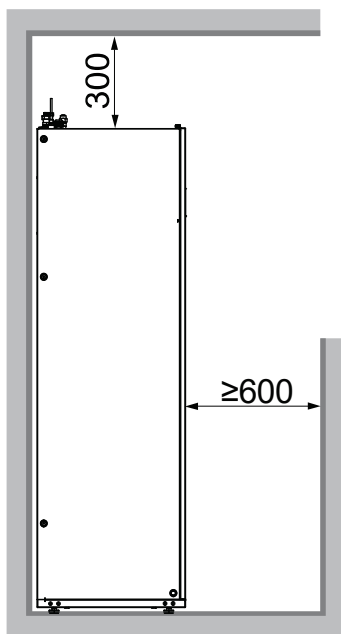

Unit:mm

Fig.4-2

4.4 Mounting the indoor unit

Lift the indoor unit from the pallet and place it on the floor.

Slide the indoor unit into position.

Adjust the height of the leveling feet (Refer to Fig.4-3) to compensate for floor irregularities. The maximum allowed deviation is 1° (Refer to Fig. 4-4)

Be specially careful with the mounting foot once the unit is on the floor. Avoid harsh handling of the unit, as it could cause damages to the foot.

Each mounting feet can be adjusted up to 30mm, but keep all them in the factory supplied position unit has been installed in its final position.

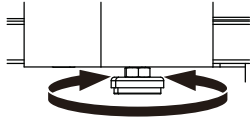

Fig.4-3

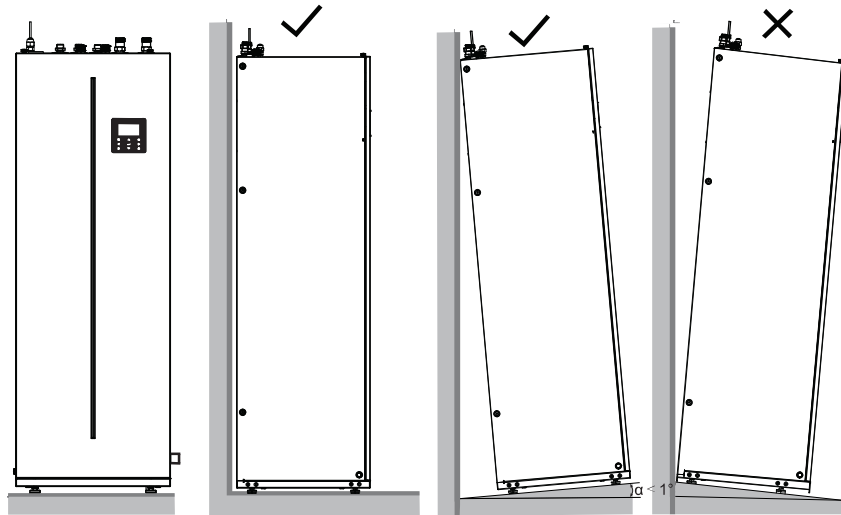

Fig.4-4

5 CONNECTING THE REFRIGERANT PIPING

For all guidelines, instructions and specifications regarding refrigerant pipe between the indoor unit and outdoor unit, please refer to "Installation and owner's manual " (M-thermal split outdoor unit).
Connecting the 16mm refrigerant pipe to the refrigerant gas connection.

- Sufficiently tighten the flare nut (Refer to Fig.5-3)
- Check the tightening torque (Refer to the right table) .
- Tighten it with a spanner and torque wrench (Refer to Fig.5-4)
- The protective nut is a one-time part, it can not be reused. In case it is removed, it should be replaced with a new one. (Refer to Fig.5-5)

Outer diam.	Tightening torque(N.cm)	Additional tightening torque(N.cm)
φ 6.35	1500 (153kgf.cm)	1600 (163kgf.cm)
φ 9.52	2500 (255kgf.cm)	2600 (265kgf.cm)
φ 16	4500 (459kgf.cm)	4700 (479kgf.cm)

⚠ CAUTION

- When connecting the refrigerant pipes, always use two wrenches/spanners to tighten or loosen the nuts ! (Refer to Fig.5-4) Otherwise, it will cause damage of piping connections and leakage .
- If the indoor unit is matched with outdoor unit (4/6kW), the transfer 9.52-6.35(Refer to the table in Page 8) should be mounted on the refrigerant liquid connection of indoor unit(Refer to Fig.5-2); The transfer is not used in other types of outdoor unit(8/10/12/14/16kW).

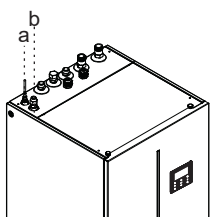

Fig.5-1

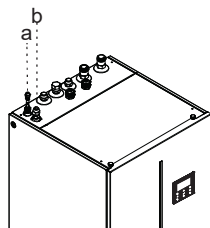

Fig.5-2

a Refrigerant liquid connection
b Refrigerant gas connection

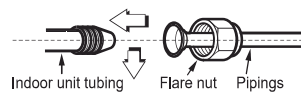

Fig.5-3

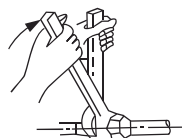

Fig.5-4

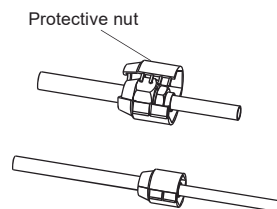

Fig.5-5

⚠ CAUTION

- Under installation conditions, excessive torque can damage the nut.
- When flared joints are reused, the flare part should be re-fabricated.

6 CONNECTING THE WATER PIPING

6.1 Connecting the space heating(cooling) water piping

To facilitate service and maintenance, two shut-off valves(field supply) and one overpressure bypass valve should be installed. The two shut-off valves should be mounted on the space heating(cooling)water inlet and outlet pipe of indoor unit.

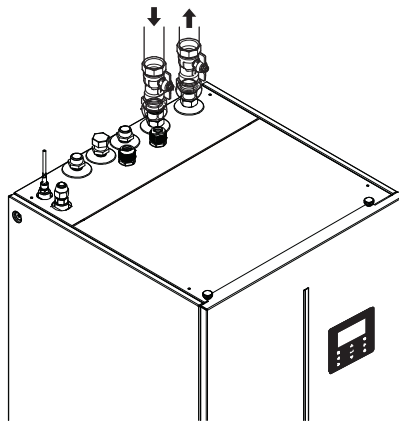

Fig.6-1

- 1.Connecting the shut-off valves to the indoor units.
- 2.Connecting the shut-off valves to the space heating(cooling) water pipes.

6.2 Connecting the domestic water piping

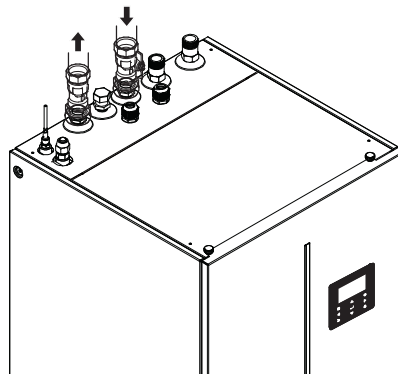

Fig.6-2

The shut-off valve should be mounted on the domestic cold water inlet.

- 1.Connect the shut-off valve to the cold water inlet of indoor unit.
- 2 Connect the cold water pipe to the shut-off valve.
- 3 Connect the domestic hot water pipe to the hot water outlet of indoor unit.

6.3 Connecting the recirculation water piping

If domestic hot water recirculation function is requested, the recirculation pipe should be connected.

1. Removing the nut of the recirculation on the indoor unit.
2. Connecting the recirculation water pipe to the indoor unit.

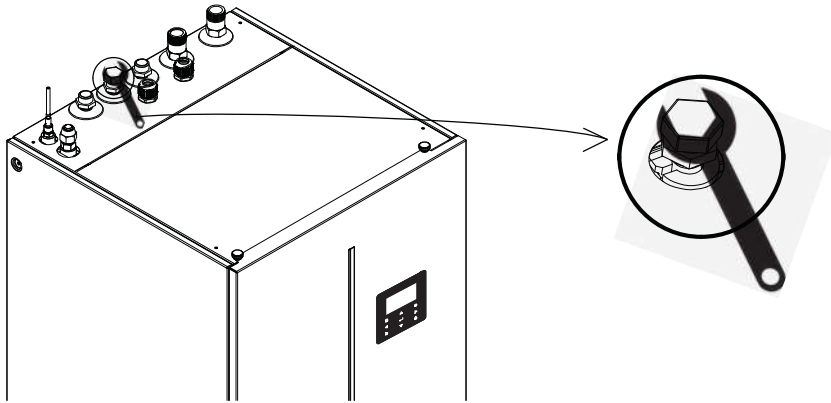

Fig.6-3

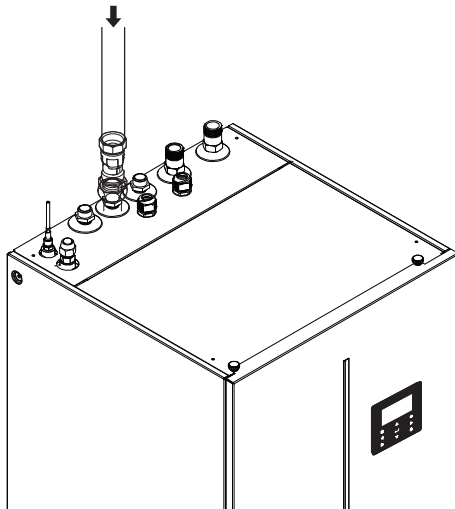

Fig.6-4

6.4 Connecting the drainage hose to the indoor unit

The water coming from the pressure relief valve and the condensate water is collected in the drainage pan. The drainage hose should be connected to the drainage pipe. Connect the drainage pipe with a throat bender and insert the drainage pipe into the floor drain.

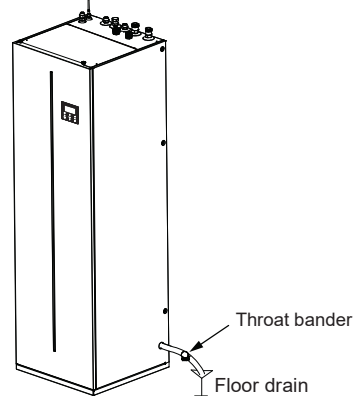

Fig.6-5

6.5 Connecting the solar circulation piping(if needed)

If the solar kit is designed in the system. The solar circulation water pipe should be connected to the inlet and outlet connector of indoor unit.

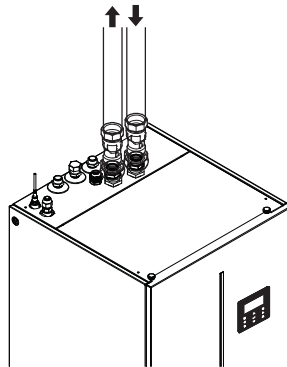

Fig.6-6

6.6 Water piping insulation

The insulation materials should be covered on the all piping in the water circuit piping system to prevent condenser water during cooling operation, the capacity reduction and freezing of the outside water piping during winter. The insulation material should at least of B1 fire resistance rating and complies with all applicable legislation. The thickness of the sealing materials must be at least 13 mm with thermal conductivity 0.039 W/mK in order to prevent freezing on the outside water piping.

If the outside temperature is higher than 30°C and the humidity is higher than RH 80%, then the thickness of the insulation materials should be at least 20 mm in order to avoid condensation on the surface of the insulation piping.

6.7 Water circuit anti-freeze protection

All hydronic parts inside of the unit are insulated to reduce the heat lose. Insulation materials must be added on the field water piping.

The unit program has special functions which use the heat pump and backup heater (if available) to protect the entire system from freezing. When the temperature of the water flow in the system drops to a certain value, the unit will heat the water by using the heat pump or the electric heating tap or the backup heater. The anti-freeze protection function will turn off only when the temperature increases to a certain value.

When unit lose the power, the above function will not active to protect the unit from freezing.

⚠ CAUTION

When the unit is not running for a long time, make sure the unit is powered on all the time. If the unit should be cut off the power, make sure the water in the piping of the system should be drained completely to avoid the water pump and piping system being damaged by freezing. The power of the unit also needs to be cut off after water in the system is drained.

Water may enter into the flow switch and cannot be drained out, it may freeze when the temperature is low enough. The flow switch should be removed and dried, then can be reinstalled in the unit.

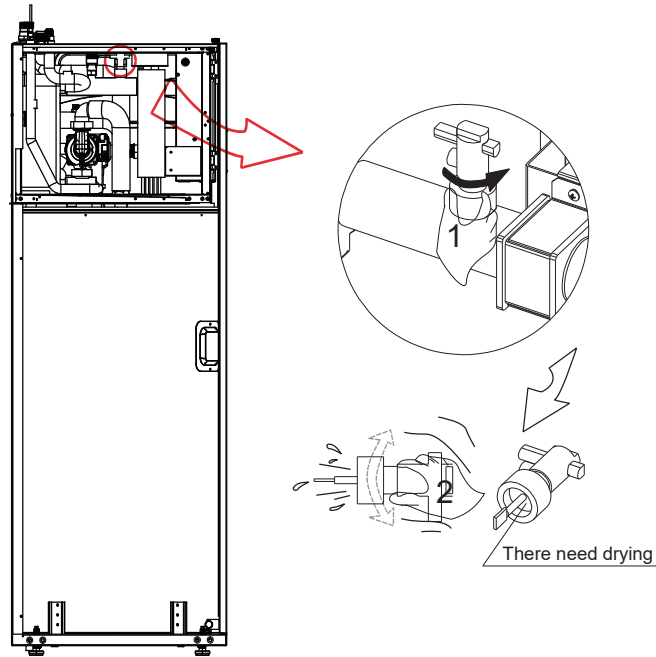

Fig.6-7

NOTE

- 1.Counterclockwise rotation, remove the flow switch.
- 2.Dry the flow switch completely.

CAUTION

Be careful not to deform the unit's piping by using excessive force when connecting the piping. Deforming the piping may lead to malfunction of heat pump.

If air, moisture or dust gets in the water circuit, problems may occur. Therefore, always take into account the following when connecting the water circuit:

- Use clean pipes only.
- Hold the pipe end downwards when removing burrs.
- Cover the pipe end when inserting it through a wall to prevent dust and dirt entering.
- Use a good thread sealant for sealing the connections. The sealing must be able to withstand the pressures and temperatures of the system.
- When using non-copper metallic piping, be sure to insulate two kind of materials from each other to prevent galvanic corrosion.
- As copper is a soft material, use appropriate tools for connecting the water circuit. Inappropriate tools will cause damage to the pipes

NOTE

The unit is only to be used in a closed water system. Application in an open water circuit can lead to excessive corrosion of the water piping:

- Never use Zn-coated parts in the water circuit. Excessive corrosion of these parts may occur as copper piping is used in the unit's internal water circuit.
- When using a 3-way valve in the water circuit. Preferably choose a ball type 3-way valve to guarantee full separation between the domestic hot water and floor heating water circuit.
- When using a 3-way valve or a 2-way valve in the water circuit. The recommended maximum changeover time of the valve should be less than 60 seconds.

6.8 Filling water

6.8.1 Filling the water circuit

- Connect the water supply to the filling valve and open the valve.
- Make sure all the automatic air purge valves are open (at least 2 turns).
- Filling with water until the manometer(field supply) indicates a pressure of approximately 2.0 bar. Remove air in the circuit as much as possible using the automatic air purge valves.

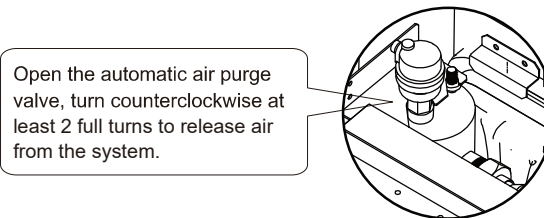

Fig.6-8

NOTE

During filling, it might not be possible to remove all air in the system. Remaining air will be removed through the automatic air purge valve during the first operating hours of the system. Topping up the water afterwards might be required.

- The water pressure indicated on the manometer will vary depending on the water temperature (higher pressure at higher water temperature). However, at all times water pressure should remain above 0.5 bar to avoid air entering the circuit. The unit might drain-off too much water through the pressure relief valve.
- Water quality should be complied with EN 98/83 EC Directives.
- Detailed water quality condition can be found in EN 98/83 EC Directives.

NOTE

- In most applications this minimum water volume will be satisfactory.
- In critical processes or in rooms with a high heat load though, extra water might be required.
- When circulation in each space heating loop is controlled by remotely controlled valves, it is important that this minimum water volume is kept even if all the valves are closed.
- if each space heating (cooling loop is controlled by the valves, the overpressure bypass valve(field supply) should be mounted between the heating(cooling) loops.

6.8.2 Filling the domestic hot water tank

- 1 Open every hot water tap in turn to purge air from the pipes of the system.
- 2 Open the cold water supply valve.
- 3 Close all water taps after all air is purged.
- 4 Check for water leakage.
- 5 Manually operate the field-installed pressure relief valve to ensure a free water flow through the discharge pipe.

CAUTION

- Cold water inlet pressure should be less than 1.0MPa. Expansion vessel and safety valve (field supply, protection pressure is 1.0MPa) must be installed.
- Warning and Water Quality Directive and Groundwater: This product is designed to comply with the European Water Quality Directive 98/83/EC amended by 2015/1787/EU. The lifespan of the product is not guaranteed in the case of the use of groundwater, such as spring water or well water, the use of tap water when salt or other impurities are contained, nor in areas of acidic water quality. Maintenance and warranty costs related to these cases are the customer's responsibility.

6.9 TYPICAL APPLICATIONS

6.9.1 Application1

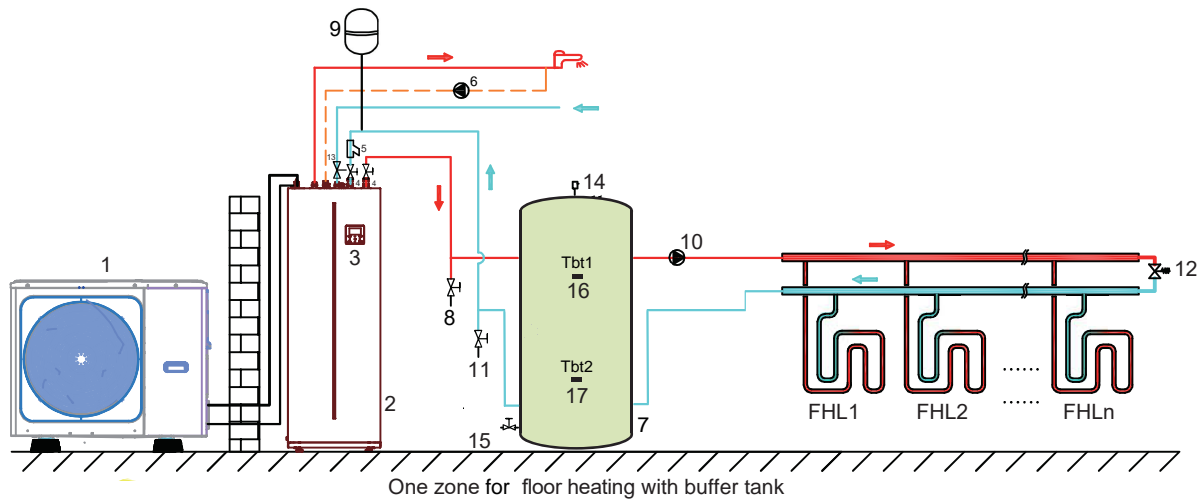

Code	Assembly unit	Code	Assembly unit
1	Outdoor unit	13	Pressure relief valve (field supply)
2	Indoor unit with tank	14	Automatic air purge valve
3	User interface (Display)	15	Drainage valve
4	Shut-off valve (field supply)	16	Tbt1: temperature sensor of buffer tank 1 (field supply)
5	Filter (accessories)	17	Tbt2: temperature sensor of buffer tank 2 (field supply)
6	P_d: water pump DHW (field supply)		
7	Buffer tank (field supply)		
8	Drainage valve (field supply)		
9	Expansion vessel (field supply)		
10	External water pump (field supply)		
11	Filling valve (field supply)		
12	Bypass valve (field supply)		

6.9.2 Application 2

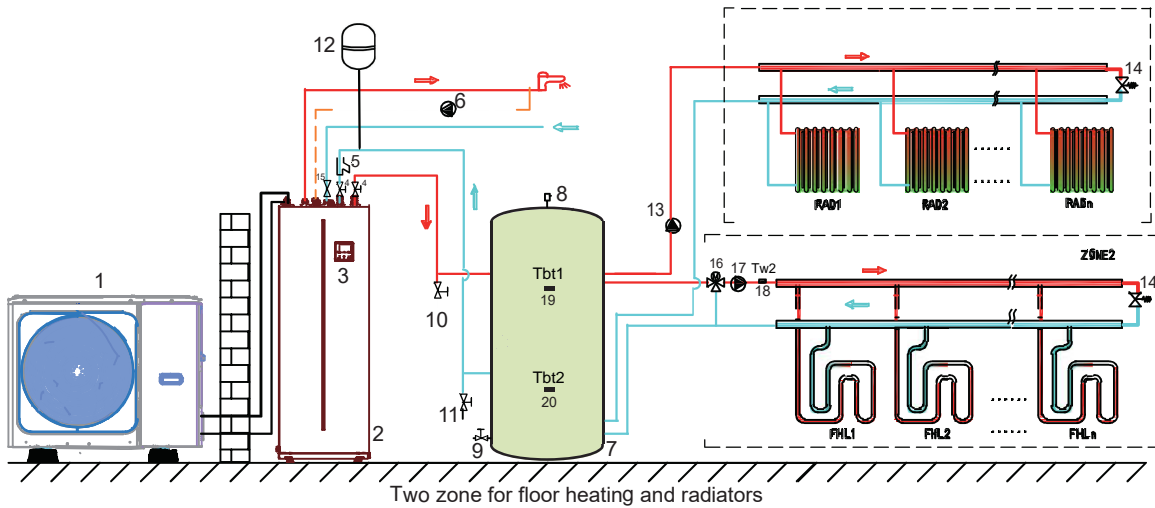

Code	Assembly unit	Code	Assembly unit
1	Outdoor unit	13	External water pump (field supply)
2	Outdoor unit	14	Bypass valve (field supply)
3	User interface (Display)	15	Pressure relief valve (field supply)
4	Shut-off valve (field supply)	16	SV3: 3-way valve (field supply)
5	Filter (accessories)	17	P_c: water pump zone 2 (field supply)
6	P_d: water pump DHW (field supply)	18	Tw2: temperature sensor zone 2 (field supply)
7	Buffer tank (field supply)	19	Tbt1: temperature sensor of buffer tank 1 (field supply)
8	Automatic air purge valve	20	Tbt2: temperature sensor of buffer tank 2 (field supply)
9	Drainage valve		
10	Drainage valve (field supply)		
11	Filling valve (field supply)		
12	Expansion vessel (field supply)		

6.9.3 Application 3

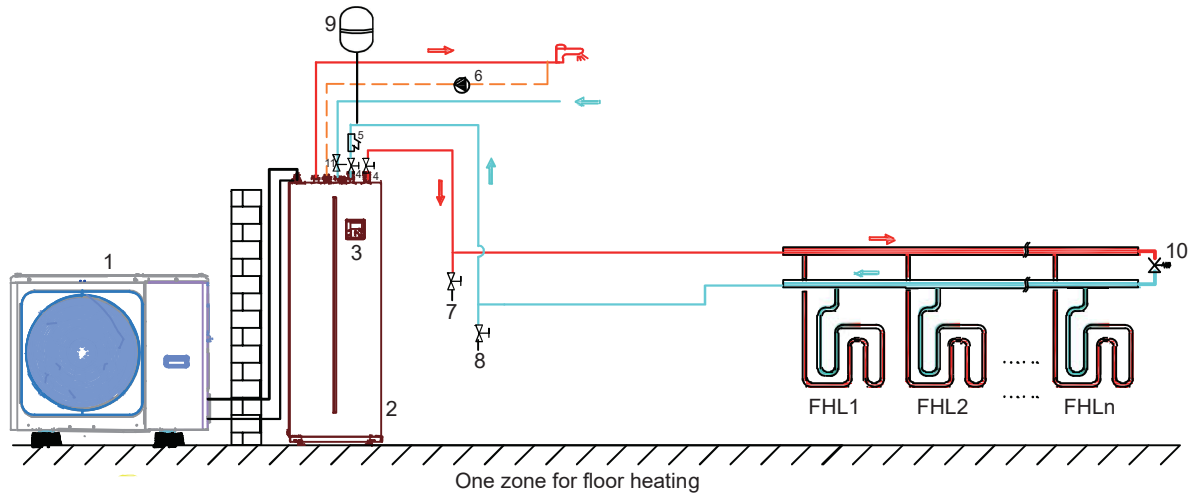

Code	Assembly unit
1	Outdoor unit
2	Indoor unit with tank
3	User interface (Display)
4	Shut-off valve (field supply)
5	Filter (accessories)
6	P_d: water pump DHW (field supply)
7	Drainage valve (field supply)
8	Filling valve (field supply)
9	Expansion vessel (field supply)
10	Bypass valve (field supply)
11	Pressure relief valve (field supply)

Space heating/cooling

One zone application

- 1)When the unit is ON, P_o keeps running, if unit is OFF, P_o stops running
- 2) When the unit cooling mode is ON, SV2 keeps OFF
- 3) When the unit heating mode is ON, SV2 keeps ON,

Double zone application

When zone 1 is ON, P_o keeps running, if zone 1 is OFF, P_o stops running

When zone 2 is ON, P_c keeps running , SV3 switches between ON and OFF according to the Tw2 sensor,if zone 2 is OFF, SV3 keeps OFF, P_c stops running.

The floor heating loops require a lower water temperature in heating mode compared to Radiators or fan coil. To achieve these two set points, a mixing station is used to adapt the water temperature according to requirements of the floor heating loops. The radiators are directly connected to the unit water circuit and the floor heating loops are after the mixing station. The mixing station includes SV3,P_c and Tw2, can be controlled by indoor unit.

Domestic water heating

The ON/OFF signal and target tank water temperature (T5S) are set on the user interface.

P_o/P_c stops running as long as the unit is ON for domestic water heating.

Solar energy control

Indoor unit recognizes solar energy signal by judging Tsolar or receiving SL1SL2 signal.

The control method can be set via "FOR SERVICEMAN>>INPUT DEFINE>>SOLAR INPUT "on the user interface.

1)When Tsolar control is set to be valid

P_s starts running, if Tsolar is higher enough than T5.

P_s stops running, if Tsolar is lower than T5.

2)When SL1SL2 control is set to be valid

P_s starts running, if SL1SL2 receives a closed signal.

P_s stops running, if SL1SL2 receives a open signal.

NOTE

1. Install air purge valves at all local high points
2. Drainage valve must be installed at the lowest position of the piping system.
3. A pressure relief valve with an opening pressure of maximum 10 bar (= 1 MPa) must be installed on the domestic cold water inlet connection in accordance with the applicable legislation.

7 FIELD WIRING

WARNING

A main switch or other means of disconnection, having a contact separation in all poles, must be incorporated in the fixed wiring in accordance with relevant local laws and regulations. Switch off the power supply before making any connections. Use only copper wires. Never squeeze bundled cables and make sure they do not come in contact with the piping and sharp edges. Make sure no external pressure is applied to the terminal connections. All field wiring and components must be installed by a licensed electrician and must comply with relevant local laws and regulations.

The field wiring must be carried out in accordance with the wiring diagram supplied with the unit and the instructions given below.

Be sure to use a dedicated power supply. Never use a power supply shared by another appliance.

Be sure to establish a ground. Do not ground the unit to a utility pipe, surge protector, or telephone ground. Incomplete grounding may cause electrical shock.

Be sure to install a ground fault circuit interrupter (30 mA). Failure to do so may cause electrical shock.

Be sure to install the required fuses or circuit breakers.

7.1 Precautions on electrical wiring work

- Fix cables so that cables do not make contact with the pipes (especially on the high pressure side).
- Secure the electrical wiring with cable ties as shown in figure so that it does not come in contact with the piping, particularly on the high-pressure side.
- Make sure no external pressure is applied to the terminal connectors.
- When installing the ground fault circuit interrupter make sure that it is compatible with the inverter (resistant to high frequency electrical noise) to avoid unnecessary opening of the ground fault circuit interrupter.

NOTE

The ground fault circuit interrupter must be a high-speed type breaker of 30 mA (<0.1 s).

NOTE

- Maximum length of communication wirings is 50m.
- Power cords and communication wiring must be laid out separately, they can not be placed in the same conduit. Otherwise, it may lead to electromagnetic interference. Power cords and communication wirings should not come in contact with the refrigerant pipe so as to prevent the high temperature pipe from damaging the wires.
- Communication wirings must use shielded lines. Including indoor unit to outdoor unit PQE line, indoor unit to controller ABXYE line.

- This unit is equipped with an inverter. Installing a phase advancing capacitor not only will reduce the power factor improvement effect, but also may cause abnormal heating of the capacitor due to high-frequency waves. Never install a phase advancing capacitor as it could lead to an accident.
- Equipment must be grounded.
- All high-voltage external load, if it is metal or a grounded port, must be grounded.
- All external load current is needed less than 0.2A, if the single load current is greater than 0.2A, the load must be controlled through AC contactor.

7.2 Precautions on wiring of power supply

- Use a round crimp-style terminal for connection to the power supply terminal board. In case it cannot be used due to unavoidable reasons, be sure to observe the following instructions.
- Do not connect different gauge wires to the same power supply terminal. (Loose connections may cause overheating.)
- When connecting wires of the same gauge, connect them according to the figure below.

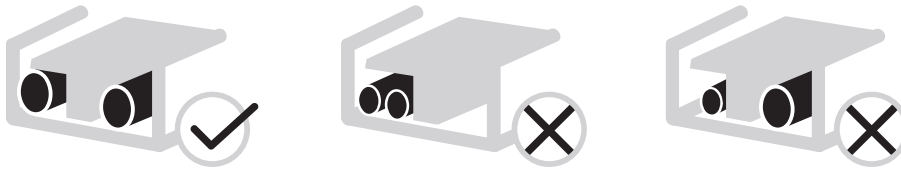

Fig.7-1

- Use the correct screwdriver to tighten the terminal screws. Small screwdrivers can damage the screw head and prevent appropriate tightening.
- Over-tightening the terminal screws can damage the screws.
- Attach a ground fault circuit interrupter and fuse to the power supply line.
- In wiring, make certain that prescribed wires are used, carry out complete connections, and fix the wires so that outside force cannot affect the terminals.

7.3 Safety device requirements

1. Select the wire diameters(minimum value) individually for each unit based on the table below.

Model	Power supply	Circuit breaker	Power supply cable (mm ²)	Inrush current	Nominal current	Maximum current (rated)
	V, phase, Hz	(A)		(A)	(A)	(A)
MSH-60EB	230V~; 1 phase; 50 Hz	16	CYKY-J 3x2,5	1	5,5	12
MSH-80EB		16	CYKY-J 3x2,5	1	7	14,5
MSH-100EB		20	CYKY-J 3x4	1	8,7	16
MSH-120EB		32	CYKY-J 3x10	1	10,7	24,5
MSH-140EB		32	CYKY-J 3x10	1	13,5	25
MSH-160EB		32	CYKY-J 3x10	1	15,5	26
MSH-120EB-3	400V~; 3 phase; 50 Hz	16	CYKY-J 5x2,5	1	3,6	9
MSH-140EB-3		16	CYKY-J 5x2,5	1	4,4	10
MSH-160EB-3		16	CYKY-J 5x2,5	1	5,2	11
MSH-190TB/3	230V~; 1 phase; 50 Hz	16	CYKY-J 3x2,5	13,5	13,5	13,5
MSH-240TB/3		16	CYKY-J 3x2,5	13,5	13,5	13,5
MSH-190TB-3/9	400V~; 3 phase; 50 Hz	16	CYKY-J 5x2,5	4,5	13,5	13,5
MSH-240TB-3/9		16	CYKY-J 5x2,5	4,5	13,5	13,5

7.4 Before connecting the wiring

- 1.Remove the bolt in the lower left corner of indoor unit.
- 2.Open the front panel.
- 3.Remove the cover of the control box.

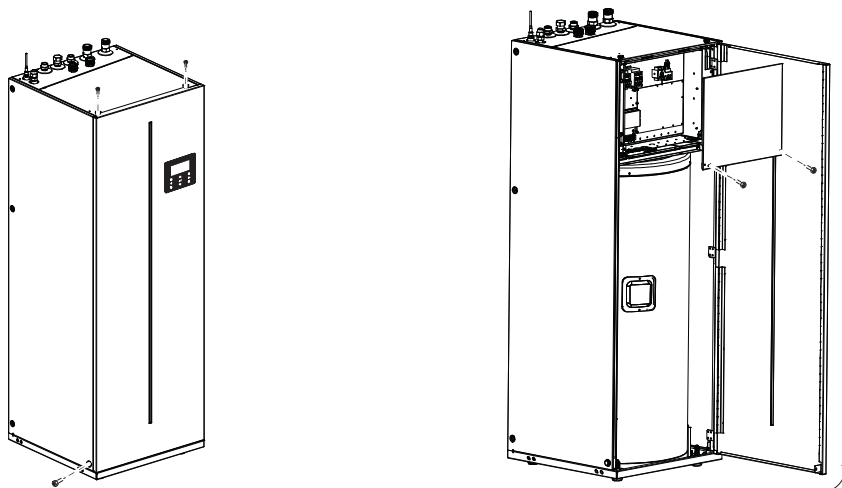

Fig.7-2

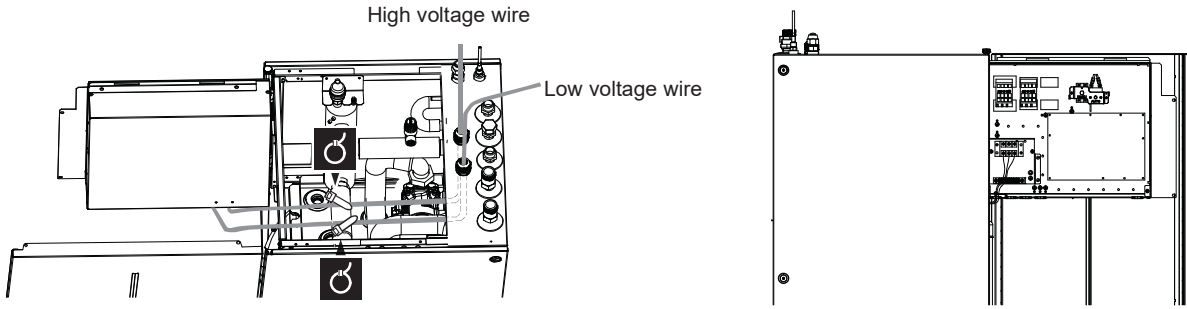
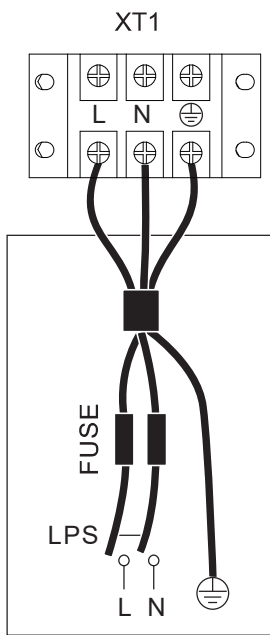

Fig.7-3

7.5 Connecting the main power supply

NOTE

Leakage Protection Switch must be installed to the Power Supply of the unit.



INDOOR UNIT
POWER SUPPLY
1-phase 3kW backup heater
standard

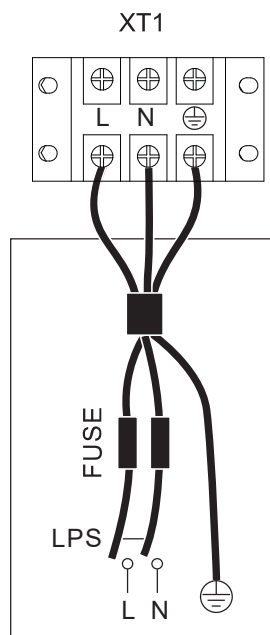

INDOOR UNIT
POWER SUPPLY
1-phase 6kW backup heater
optional

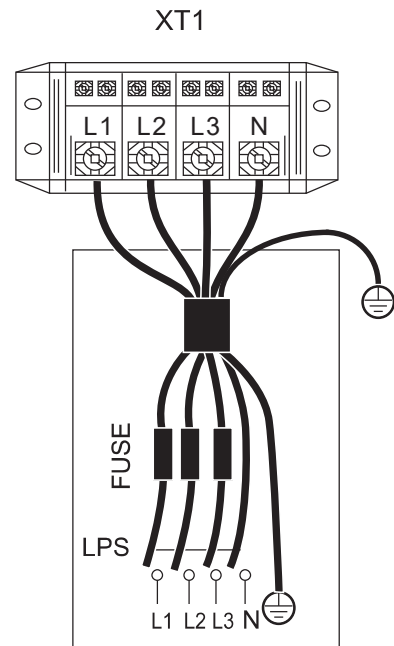

INDOOR UNIT
POWER SUPPLY
3-phase 9kW backup heater
optional

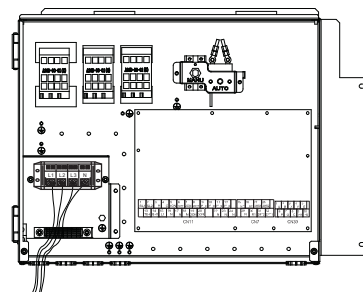
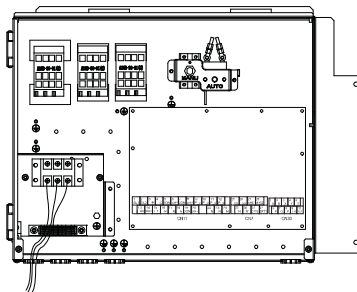
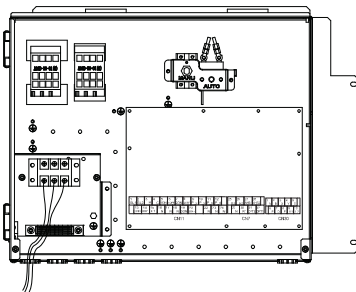

Unit	3kW-1PH	6kW-1PH	9kW-3PH
Wiring size(mm ²)	4.0	8.0	4.0

- Stated values are maximum values (see electrical data for exact values).

NOTE

The ground fault circuit interrupter must be a high-speed type breaker of 30 mA (<0.1 s). Flexible cord must meet 60245IEC(H05VV-F) standards.

7.6 Connecting for other components

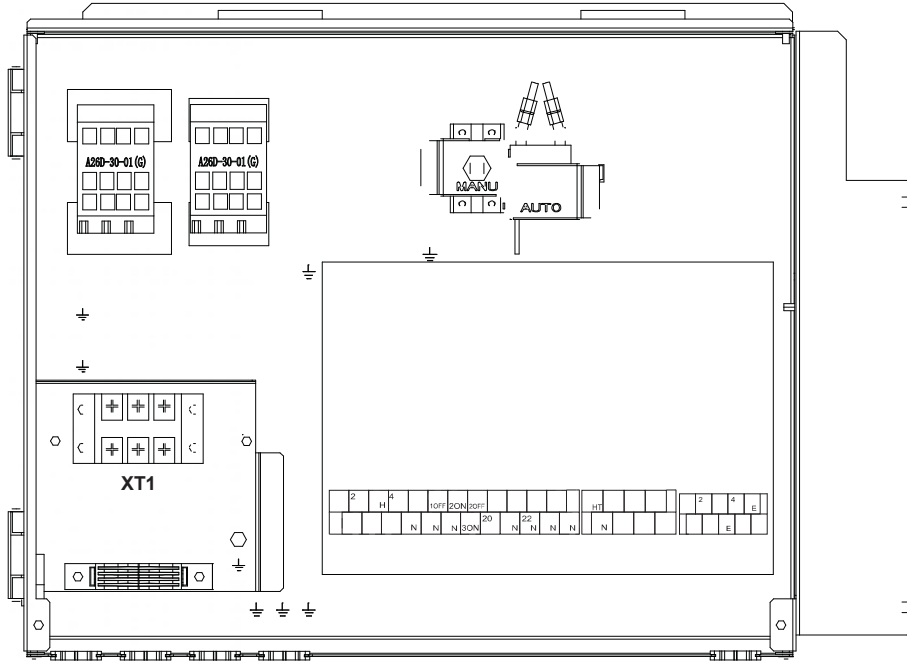

	Print	Connect to
CN11	1	SL1
	2	SL2
	3	H
	4	C
	15	L1
	5	1ON
	6	1OFF
	16	N
	7	2ON
	8	2OFF
	17	N
	9	P_c
	21	N
	10	P_o
	22	N
	11	P_s
	23	N
	12	P_d
	24	N
	13	TBH
16	N	
14	IBH1	
17	N	
18	N	
19	3ON	
20	3OFF	

	Print	Connect to
CN7	26	R2
	30	R1
	31	DFT2
	32	DFT1
	25	HT
	29	N
	27	AHS1
28	AHS2	

	Print	Connect to
CN30	1	A
	2	B
	3	X
	4	Y
	5	E
	6	P
	7	Q
	8	E
	9	H1
	10	H2

Port provide the control signal to the load. Two kind of control signal port:

Type 1 : Dry connector without voltage.

Type 2 : Port provide the signal with 220V voltage. If the current of load is <0.2A, load can connect to the port directly.

If the current of load is >=0.2A, the AC contactor is required to be connected for the load.

7.6.1 connecting the communication wire to outdoor unit

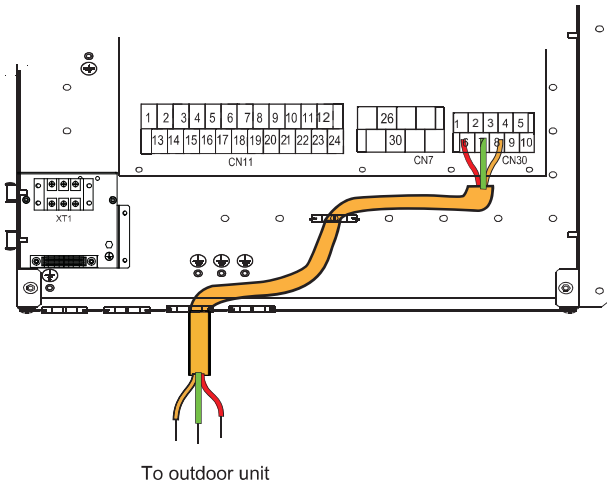

7.6.2 For remote shut down:

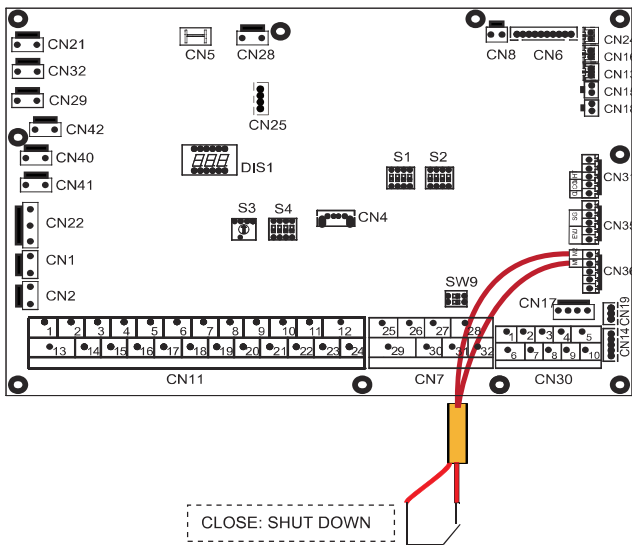

7.6.3 Room thermostat (Low voltage):

There are three methods for connecting the thermostat cable (as described in the pictures) and it depends on the application.

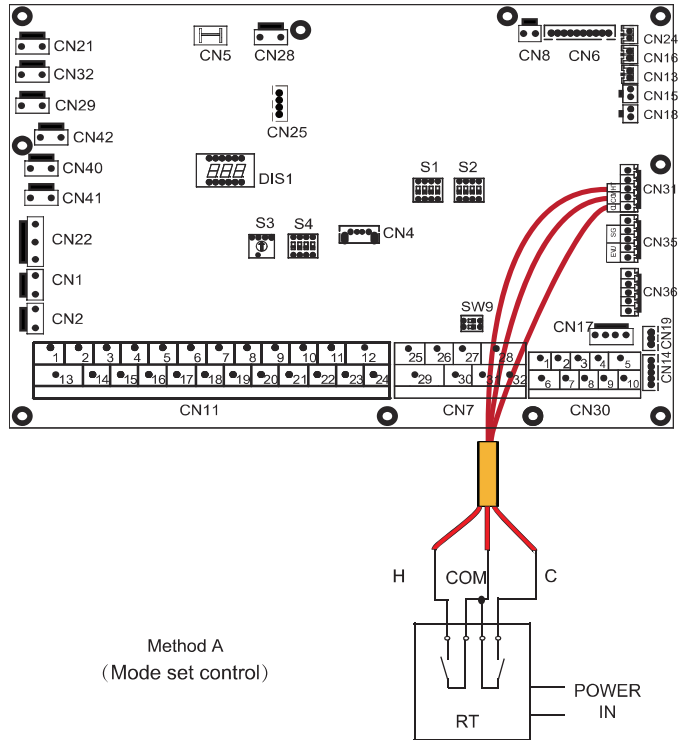

Method A
(Mode set control)

RT=Room Thermostat

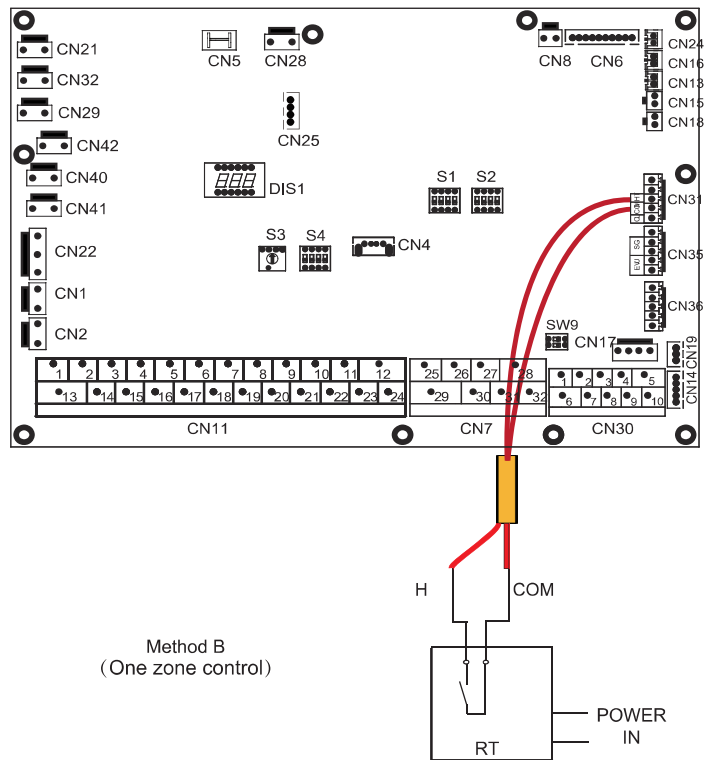

Method B
(One zone control)

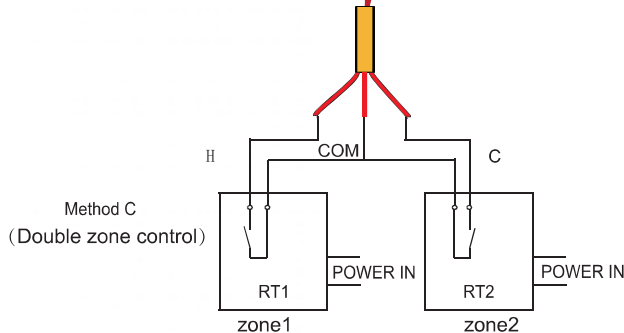
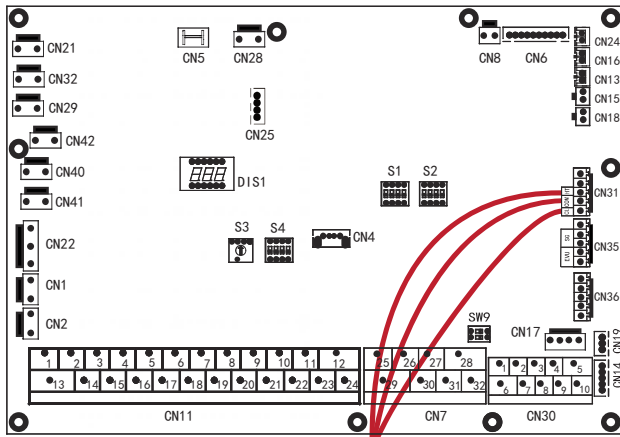

RT1=1# Room Thermostat
RT2=2# Room Thermostat

• **Method A** (Mode set control)

RT can control heating and cooling individually, like the controller for 4-pipe FCU. When the indoor unit is connected with the external temperature controller, user interface FOR SERVICEMAN set ROOM THERMOSTAT to MODE SET:

- A.1 When unit detect voltage is 12VDC between CL and COM, the unit operates in the cooling mode.
- A.2 When unit detect voltage is 12VDC between HT and COM, the unit operates in the heating mode.
- A.3 When unit detect voltage is 0VDC for both side(CL-COM, HT-COM) the unit stop working for space heating or cooling.
- A.4 When unit detect voltage is 12VDC for both side(CL-COM, HT-COM) the unit working in cooling mode.

• **Method B** (One zone control)

RT provide the switch signal to unit. User interface FOR SERVICEMAN set ROOM THERMOSTAT to ONE ZONE:

- B.1 When unit detect voltage is 12VDC between HT and COM, unit turns on.
- B.2 When unit detect voltage is 0VDC between HT and COM, unit turns off.

• **Method C** (Double zone control)

Indoor unit is connected with two room thermostat, while user interface FOR SERVICEMAN set ROOM THERMOSTAT to DOUBLE ZONE:

- C.1 When unit detect voltage is 12VDC between HT and COM, zone1 turn on. When unit detect voltage is 0VDC between HT and COM, zone1 turn off.
- C.2 When unit detect voltage is 12VDC between CL and COM, zone2 turn on according to climate temp curve. When unit detect voltage is 0V between CL and COM, zone2 turn off.
- C.3 When HT-COM and CL-COM are detected as 0VDC, unit turn off.
- C.4 when HT-COM and CL-COM are detected as 12VDC, both zone1 and zone2 turn on.

The wiring of the thermostat should correspond to the settings of the user interface. Refer to **ROOM THERMOSTAT**.

Power supply of machine and room thermostat must be connected to the same Neutral Line .

When ROOM THERMOSTAT is not set to NON, the indoor temperature sensor Ta can't be set to valid

Zone 2 can only operate in heating mode, When cooling mode is set on user interface and zone1 is OFF, "CL" in zone2 closes, system still keeps 'OFF'. While installation, the wiring of thermostats for zone1 and zone2 must be correct.

a) **Procedure**

Connect the cable to the appropriate terminals as shown in the picture.

Fix the cable with cable ties to the cable tie mountings to ensure stress relief.

7.6.4 For smart grid:

The unit has smart grid function, there are two ports on PCB to connect SG signal and EVU signal as following(SG is municipal power, and EVU is free power):

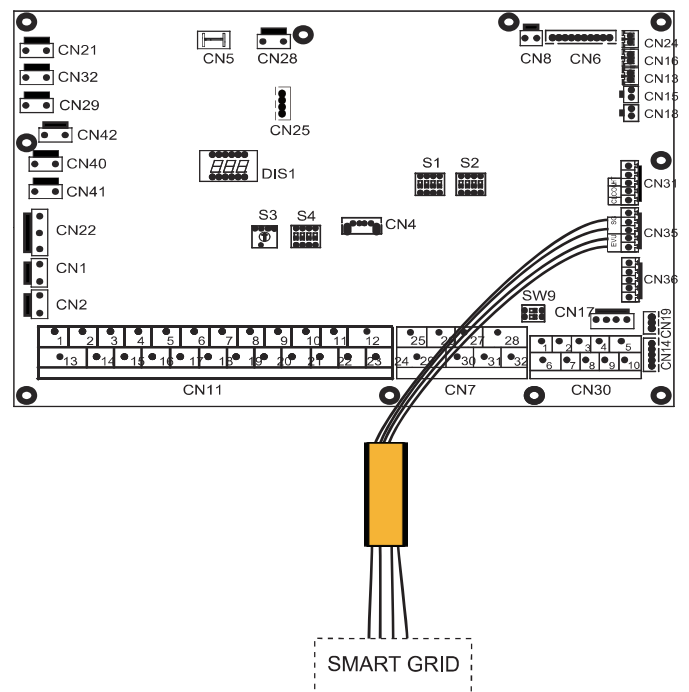

1. When EVU signal is on, and SG signal is on, as long as the DHW mode is set to be valid, the heat pump and IBH will operate in DHW mode at the same time automatically. When T5 rises to 60°C, the DHW mode will exit and switch to cooling/heating mode normally.
2. When EVU signal is on, and SG signal is off, as long as the DHW mode is set to be valid and the mode is on, the heat pump and IBH will operate in DHW mode at the same time automatically, when $T5 \geq \text{Min}(T5S+3, 60)$, the DHW mode will exit and switch to cooling/heating mode normally. (T5S is the setting temperature)
3. When EVU signal is off, SG signal is on, the unit operates normally.
4. When EVU signal is off, and SG signal is off, the unit operates as below: The unit will not operate DHW mode, and the IBH is invalid, disinfect function is invalid. The max running time for cooling/heating is "SG RUNNING TIME", then unit will be off.

7.6.5 For P_o:

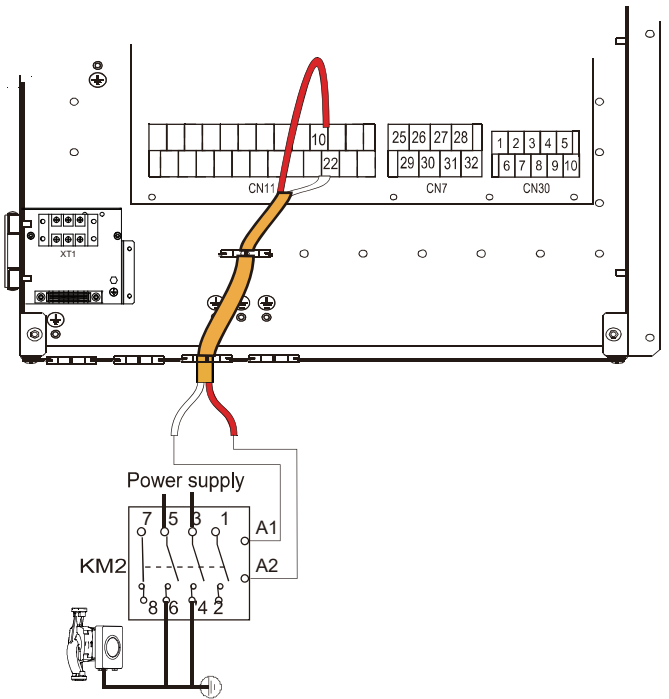

Voltage	220-240VAC
Maximum running current(A)	0.2
Wiring size(mm ²)	0.75
Control port signal type	Type 2

a) Procedure

Connect the cable to the appropriate terminals as shown in the picture.
Fix the cable with cable ties to the cable tie mountings to ensure stress relief.

7.6.6 For P_c

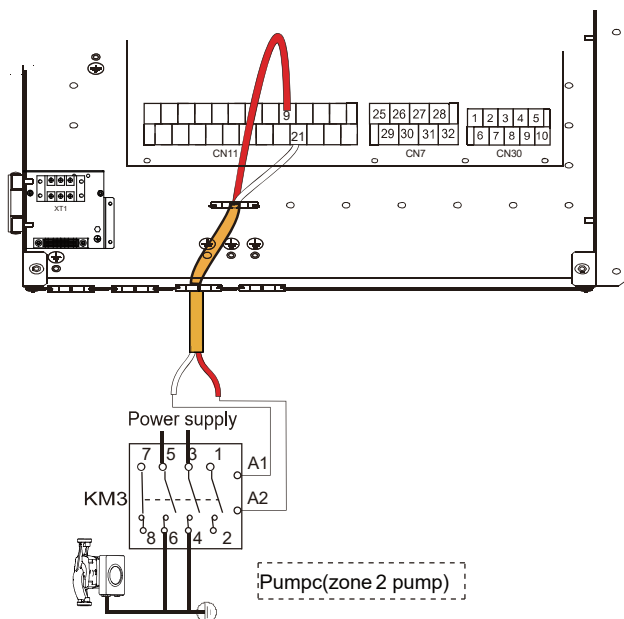

Voltage	220-240VAC
Maximum running current(A)	0.2
Wiring size(mm ²)	0.75
Control port signal type	Type 2

7.6.7 For P_d

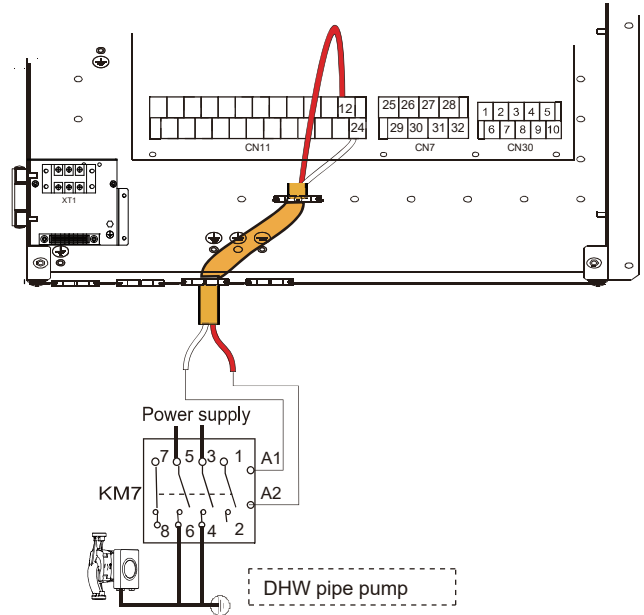

Voltage	220-240VAC
Maximum running current(A)	0.2
Wiring size(mm ²)	0.75
Control port signal type	Type 2

7.6.8 For 3-way valve SV2

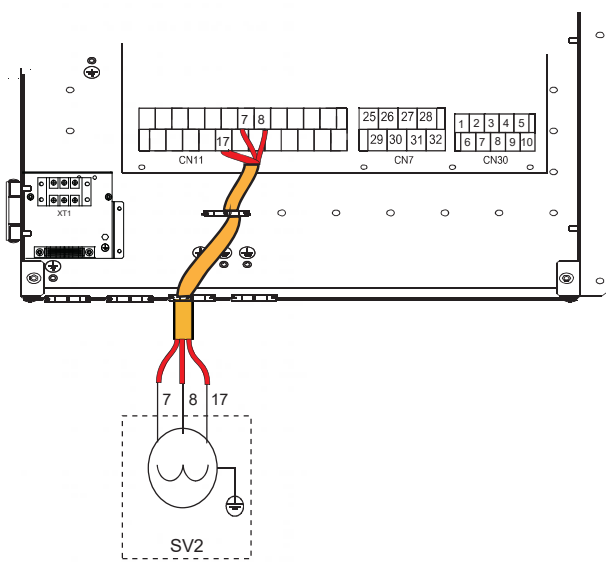

7.6.9 For 3-way valve SV3

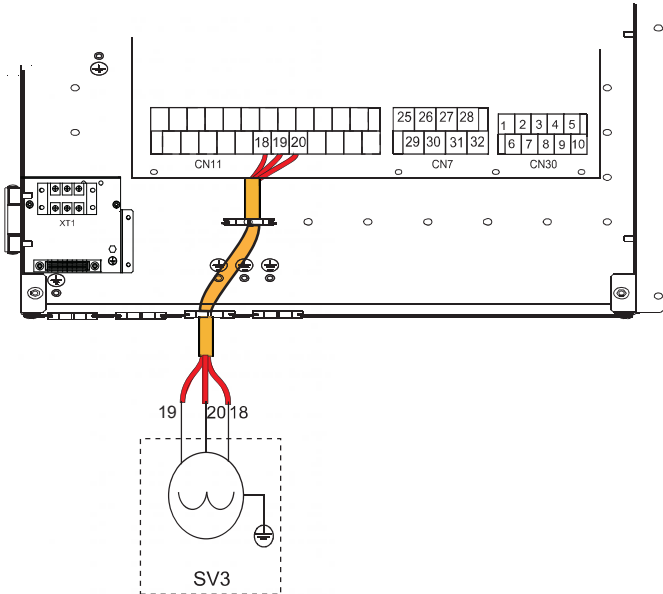

7.6.10 For defrosting signal output:

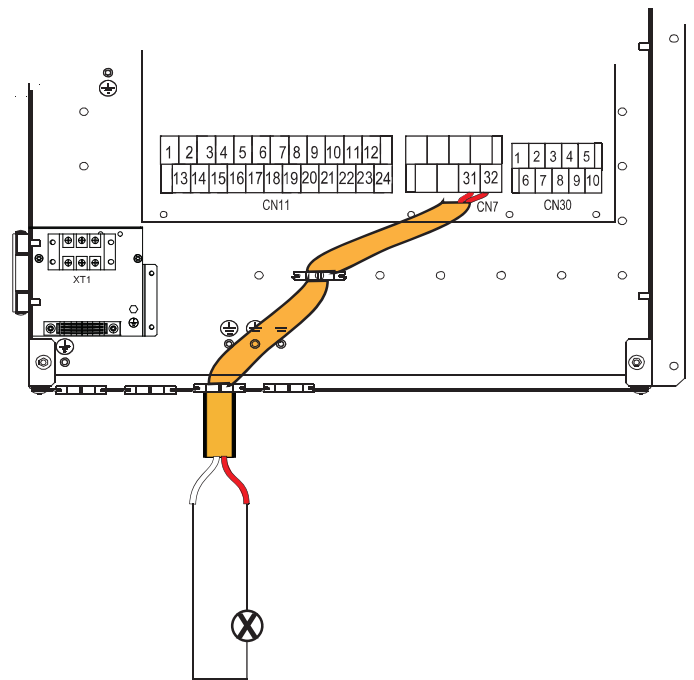

7.6.11 For unit operating status signal output

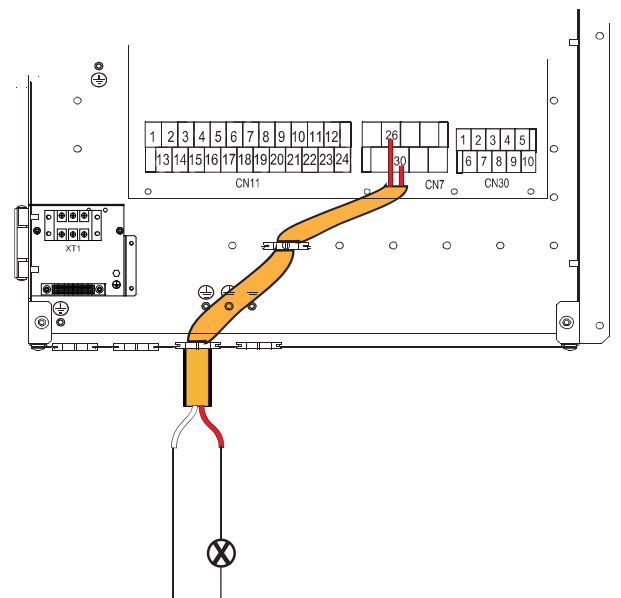

7.6.12 For room thermostat:

Room thermostat type 1(High voltage): "POWER IN" provide the working voltage to the RT, doesn't provide the voltage to the RT connector directly. Port "15 L1" provide the 220V voltage to the RT connector. Port "15 L1" connect from the unit main power supply port L of 1- phase power supply.

Room thermostat type 2(Low voltage) : "POWER IN" provide the working voltage to the RT

There are two optional connecting methods depending on the room thermostat type.

Room thermostat type 1 (High voltage):

Room thermostat type 1 (High voltage):

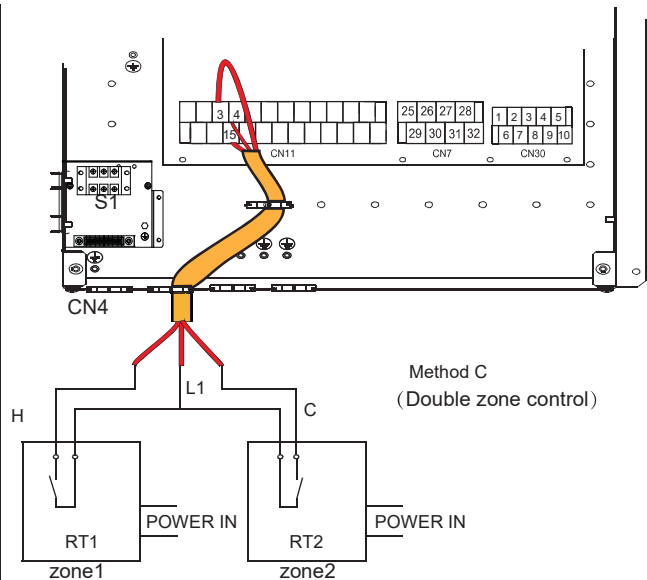
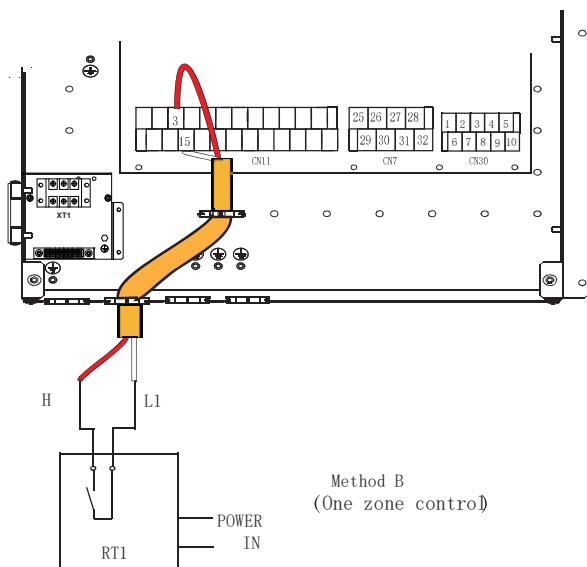
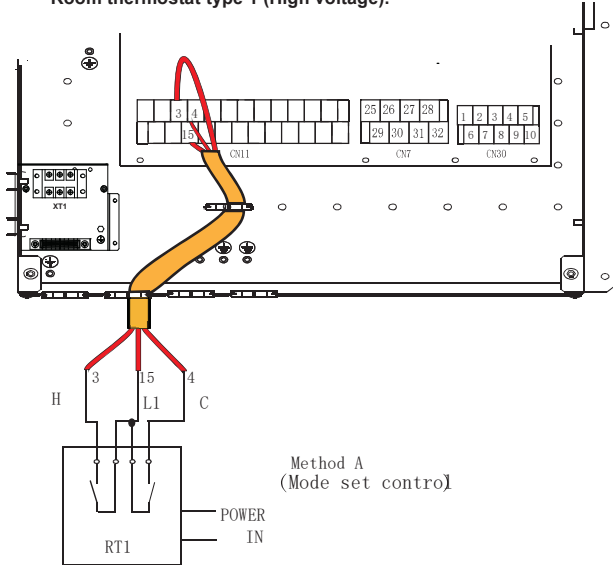

Voltage	220-240VAC
Maximum running current(A)	0.2
Wiring size(mm ²)	0.75

There are three methods for connecting the thermostat cable (as described in the picture above) and it depends on the application.

• Method A (Mode set control)

RT can control heating and cooling individually, like the controller for 4-pipe FCU. When the indoor unit is connected with the external temperature controller, user interface FOR SERVICEMAN set ROOM THERMOSTAT to MODE SET :

A.1 When unit detect voltage is 230VAC between C and L1 ,the unit operates in the cooling mode.

A.2 When unit detect voltage is 230VAC between H and L1, the unit operates in the heating mode.

A.3 When unit detect voltage is 0VAC for both side(C-L1, H-L1) the unit stop working for space heating or cooling.

A.4 When unit detect voltage is 230VAC for both side(C-L1, H-L1) the unit working in cooling mode.

• Method B (One zone control)

RT provide the switch signal to unit. User interface FOR SERVICEMAN set ROOM THERMOSTAT to ONE ZONE :

B.1 When unit detect voltage is 230VAC between H and L1, unit turns on.

B.2 When unit detect voltage is 0VAC between H and L1, unit turns off.

• Method C (Double zone control)

Indoor unit is connected with two room thermostat, while user interface FOR SERVICEMAN set ROOM THERMOSTAT to DOUBLE ZONE:

C.1 When unit detect voltage is 230VAC between H and L1 ,zone1 turns on.When unit detect voltage is 0VAC between H and L1, zone1 turns off.

C.2 When unit detect voltage is 230VAC between C and L1, zone2 turns on according to climate temp curve. When unit detect voltage is 0V between C and L1, zone2 turns off.

C.3 When H-L1 and C-L1 are detected as 0VAC, unit turns off.

C.4 when H-L1 and C-L1 are detected as 230VAC, both zone1 and zone2 turn on.

7.6.13 For solar energy input signal

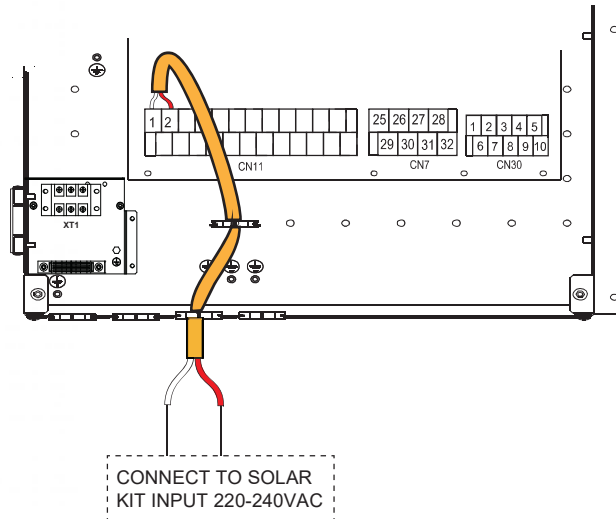

Voltage	220-240VAC
Maximum running current(A)	0.2
Wiring size(mm ²)	0.75

8 START-UP AND CONFIGURATION

The unit should be configured by the installer to match the installation environment (outdoor climate, installed options, and user expertise).

⚠ CAUTION

It is important that all information in this chapter is read sequentially by the installer and that the system is configured applicable.

8.1 Initial start-up at low outdoor ambient temperature

During initial start-up and when water temperature is low, it is important that the water is heated gradually. Failure to result in concrete floors cracking due to rapid temperature change. Please contact the responsible cast concrete contractor for further details.

To do so, the lowest water flow set temperature can be decreased to a value between 25°C and 35°C by adjusting SERVICEMAN.

8.2 Pre-operation checks

Checks before initial start-up

⚠ DANGER

Switch off the power supply before making any connections.

After the installation of the unit, check the following before switching on the circuit breaker:

- Field wiring : Make sure that the field wiring between the local supply panel and unit and valves (when applicable), unit and room thermostat (when applicable), unit and domestic hot water tank, and unit and backup heater kit have been connected according to the instructions described in the chapter 7 "FIELD WIRING", according to the wiring diagrams and to local laws and regulations.
- Fuses, circuit breakers, or protection devices Check that the fuses or the locally installed protection devices are of the size and type specified in 7.3 "Safety device requirements". Make sure that no fuses or protection devices have been bypassed.
- Backup heater circuit breaker : Do not forget to turn on the backup heater circuit breaker in the switchbox (it depends on the backup heater type). Refer to the wiring diagram.
- Booster heater circuit breaker : Do not forget to turn on the booster heater circuit breaker (applies only to units with optional domestic hot water tank installed).
- Ground wiring : Make sure that the ground wires have been connected properly and that the ground terminals are tightened.
- Internal wiring : Visually check the switch box for loose connections or damaged electrical components.
- Mounting : Check that the unit is properly mounted, to avoid abnormal noises and vibrations when starting up the unit.
- Damaged equipment : Check the inside of the unit for damaged components or squeezed pipes.
- Refrigerant leak : Check the inside of the unit for refrigerant leakage. If there is a refrigerant leak, call your local dealer.
- Power supply voltage : Check the power supply voltage on the local supply panel. The voltage must correspond to the voltage on the identification label of the unit.
- Air purge valve : Make sure the air purge valve is open (at least 2 turns).
- Shut-off valves : Make sure that the shut-off valves are fully open.

8.3 Field settings

The unit should be configured to match the installation environment (outdoor climate, installed options, etc.) and user demand. A number of field settings are available. These settings are accessible and programmable through "FOR SERVICEMAN" in user interface.

Powering on the unit

When power on the unit, "1%~99%" is displayed on the user interface during initialization. During this process the user interface cannot be operated.

Procedure

To change one or more field settings, proceed as follows.

💡 NOTE

Temperature values displayed on the wired controller (user interface) are in °C.

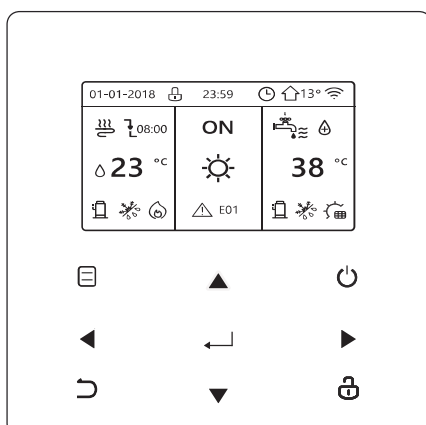

Keys	Function
	• Go to the menu structure(on the home page)
	• Navigate the cursor on the display • Navigate in the menu structure • Adjust settings
	• Turn on/off the space heating/cooling operation or DHW mode • Turn on/or off functions in the menu structure
	• Come back to the up level
	• Long press for unlock /lock the controller • Unlock /lock some functions such as "DHW temperature adjusting"
	• Go to the next step when programming a schedule in the menu structure; and confirm a selection to enter in the submenu of the menu structure.

8.4 About FOR SERVICEMAN

"FOR SERVICEMAN" is designed for the installer to set the parameters.

- Setting the composition of equipment.
- Setting the parameters.

How to go to FOR SERVICEMAN

Go to > FOR SERVICEMAN. Press :

FOR SERVICEMAN	
Please input the password:	
0 0 0	

Press to navigate and press to adjust the numerical value. Press . The password is 234, the following pages will be displayed after putting the password:

FOR SERVICEMAN	1/3
1. DHW MODE SETTING	
2. COOL MODE SETTING	
3. HEAT MODE SETTING	
4. AUTO MODE SETTING	
5. TEMP.TYPE SETTING	
6. ROOM THERMOSTAT	

FOR SERVICEMAN	2/3
7. OTHER HEATING SOURCE	
8. HOLIDAY AWAY MODE SET	
9. SERVICE CALL SETTING	
10. RESTORE FACTORY SETTINGS	
11. TEST RUN	
12. SPECIAL FUNCTION	

FOR SERVICEMAN	3/3
13. AUTO RESTART	
14. POWER INPUT LIMITATION	
15. INPUT DEFINE	
16. CASCADE SET	
17. HMI ADDRESS SET	

Press to scroll and use "

8.4.1 DHW MODE SETTING

DHW = domestic hot water

Go to > FOR SERVICEMAN> 1.DHW MODE SETTING. Press . The following pages will be displayed:

1 DHW MODE SETTING	1/5
1.1 DHW MODE	YES
1.2 DISINFECT	YES
1.3 DHW PRIORITY	YES
1.4 PUMP_D	YES
1.5 DHW PRIORITY TIME SET	NON

1 DHW MODE SETTING	2/5
1.6 dT5_ON	5 °C
1.7 dT1S5	10 °C
1.8 T4DHWMAX	43 °C
1.9 T4DHWMIN	-10 °C
1.10 t_INTERVAL_DHW	5 MIN

1 DHW MODE SETTING	3/5
1.11 dT5_TBH_OFF	5 °C
1.12 T4_TBH_ON	5 °C
1.13 t_TBH_DELAY	30 MIN
1.14 T5S_DISINFECT	65 °C
1.15 t_DI_HIGHTEMP.	15MIN

1 DHW MODE SETTING	4/5
1.16 t_DI_MAX	210 MIN
1.17 t_DHWHP_RESTRICT	30 MIN
1.18 t_DHWHP_MAX	120 MIN
1.19 PUMP_D TIMER	YES
1.20 PUMP_D RUNNING TIME	5 MIN

1 DHW MODE SETTING	5/5
1.21 PUMP_D DISINFECT RUN	NON

8.4.2 COOL MODE SETTING

Go to > FOR SERVICEMAN> 2.COOL MODE SETTING. Press .

The following pages will be displayed:

2 COOL MODE SETTING	1/3
2.1 COOL MODE	YES
2.2 t_T4_FRESH_C	2.0HRS
2.3 T4CMAX	43°C
2.4 T4CMIN	20°C
2.5 dT1SC	5°C
ADJUST	

2 COOL MODE SETTING	2/3
2.6 dTSC	2°C
2.7 t_INTERVAL_C	5MIN
2.8 T1SetC1	10°C
2.9 T1SetC2	16°C
2.10 T4C1	35°C
ADJUST	

2 COOL MODE SETTING	3/3
2.11 T4C2	25°C
2.12 ZONE1 C-EMISSION	FCU
2.13 ZONE2 C-EMISSION	FLH
ADJUST	

8.4.3 HEAT MODE SETTING

Go to > FOR SERVICEMAN > 3.HEAT MODE SETTING. Press . The following pages will be displayed:

3 HEAT MODE SETTING	1/3
3.1 HEAT MODE	YES
3.2 t_T4_FRESH_H	2.0HRS
3.3 T4HMAX	16°C
3.4 T4HMIN	-15°C
3.5 dT1SH	5°C
ADJUST	

3 HEAT MODE SETTING	2/3
3.6 dTSH	2°C
3.7 t_INTERVAL_H	5MIN
3.8 T1SetH1	35°C
3.9 T1SetH2	28°C
3.10 T4H1	-5°C
ADJUST	

3 HEAT MODE SETTING	3/3
3.11 T4H2	7°C
3.12 ZONE1 H-EMISSION	RAD.
3.13 ZONE2 H-EMISSION	FLH
3.14 t_DELAY_PUMP	2MIN
ADJUST	

8.4.4 AUTO MODE SETTING

Go to > FOR SERVICEMAN > 4.AUTO MODE SETTING. Press , the following page will be displayed.

4 AUTO. MODE SETTING	
4.1 T4AUTO CMIN	25°C
4.2 T4AUTO HMAX	17°C
ADJUST	

8.4.5 TEMP. TYPE SETTING

About TEMP. TYPE SETTING

The TEMP. TYPE SETTING is used for selecting whether the water flow temperature or room temperature is used to control the ON/OFF of the heat pump.

When ROOM TEMP. is enabled, the target water flow temperature will be calculated from climate-related curves.

How to enter the TEMP. TYPE SETTING

Go to > FOR SERVICEMAN > 5.TEMP. TYPE SETTING. Press . The following page will be displayed:

5 TEMP. TYPE SETTING	
5.1 WATER FLOW TEMP.	YES
5.2 ROOM TEMP.	NON
5.3 DOUBLE ZONE	NON
ADJUST	

If you only set WATER FLOW TEMP. to YES, or only set ROOM TEMP. to YES, The following pages will be displayed.

01-01-2018	23:59	↑13°
	ON	
Δ 35 °C		38 °C

only WATER FLOW TEMP. YES

01-01-2018	23:59	↑13°
	ON	
23.5 °C		38

only ROOM TEMP. YES

If you set WATER FLOW TEMP. and ROOM TEMP. to YES, meanwhile set DOUBLE ZONE to NON or YES, the following pages will be displayed.

01-01-2018	23:59	↑13°	01-01-2018	23:59	↑13°
	ON			ON	
Δ 35 °C		38 °C	23.5 °C		

Homepage (zone 1)

Addition page (zone 2)

(Double zone is effective)

In this case, the setting value of zone 1 is T1S, the setting value of zone 2 is T1S2 (The corresponding T1S2 is calculated according to the climate related curves.)

If you set DOUBLE ZONE to YES and set ROOM TEMP. to NON, meanwhile set WATER FLOW TEMP. to YES or NON, the following pages will be displayed.

01-01-2018	23:59	↑13°	01-01-2018	23:59	↑13°
	ON			ON	
Δ 35 °C		38 °C	Δ 35 °C		

Homepage (zone 1)

Addition page (zone 2)

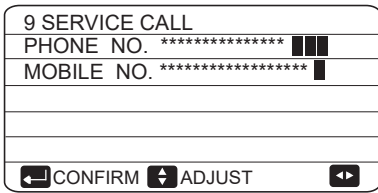

The number displayed on the user interface is the phone number of your local dealer.

8.4.10 RESTORE FACTORY SETTINGS

The RESTORE FACTORY SETTINGS is used to restore all the parameters set in the user interface to the default setting.

Go to > FOR SERVICEMAN > 10.RESTORE FACTORY SETTINGS. Press . The following page will be displayed:

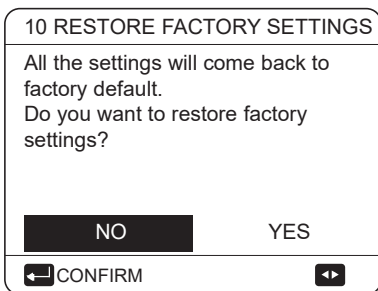

Press to scroll the cursor to YES and press . The following page will be displayed:

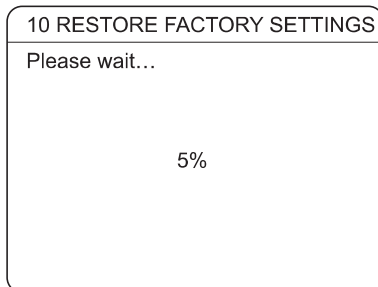

After a few seconds, all the parameters set in the user interface will be restored to factory settings.

8.4.11 TEST RUN

TEST RUN is used to check normal operation of the valves, air purge, circulation pump operation, cooling, heating and domestic water heating.

Go to > FOR SERVICEMAN> 11.TEST RUN. Press . The following page will be displayed:

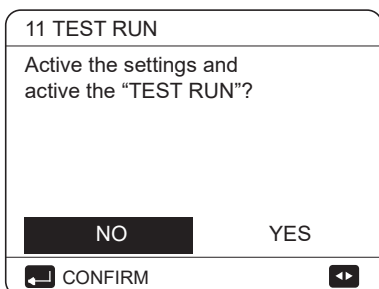

If YES is selected, the following pages will be displayed:

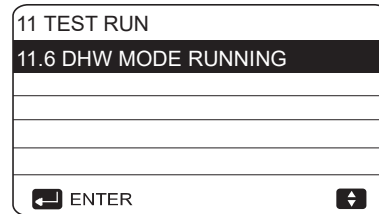
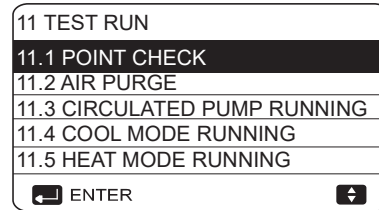

If POINT CHECK is selected, the following pages will be displayed:

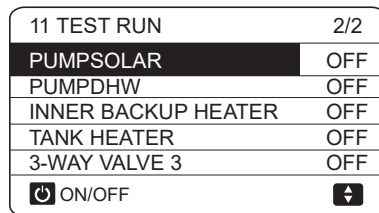
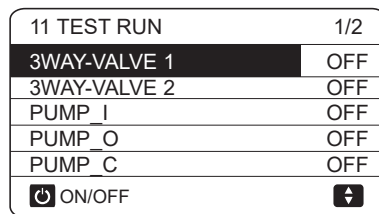

Press to scroll to the components you want to check and press . For example, when 3-way valve is selected and is pressed, if the 3-way valve is open/close, then the operation of 3-way valve is normal, and so are other components.

CAUTION

Before the point check, make sure the tank and the water system is filled with water, and air is expelled, otherwise it may cause the pump or backup heater burn out.

If you select AIR PURGE and is pressed, the following page will be displayed :

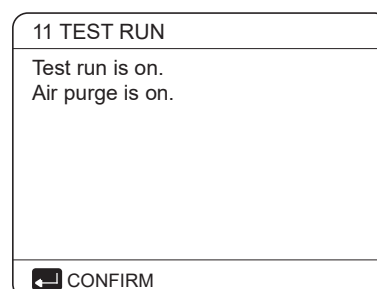

When in air purge mode, SV1 will open, SV2 will close. 60s later the pump in the unit (PUMPI) will operate for 10min during which the flow switch will not work. After the pump stops, the SV1 will close and the SV2 will open. 60s later both the PUMPI and PUMPO will operate until the next command is received.

When CIRCULATION PUMP RUNNING is selected, the following page will be displayed:

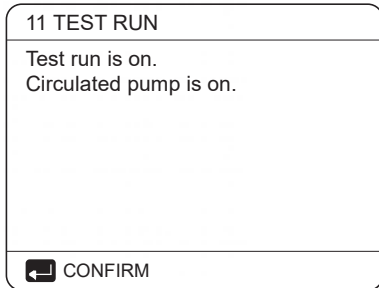

When circulation pump running is turned on, all running components will stop. 60 seconds later, the SV1 will open, the SV2 will close, 60 seconds later PUMPI will operate. 30s later, if the flow switch checked normal flow, PUMPI will operate for 3min, after the pump stops 60 seconds, the SV1 will close and the SV2 will open. 60s later the both PUMPI and PUMPO will operate, 2 mins later, the flow switch will check the water flow. If the flow switch closes for 15s, PUMPI and PUMPO will operate until the next command is received.

When the COOL MODE RUNNING is selected, the following page will be displayed:

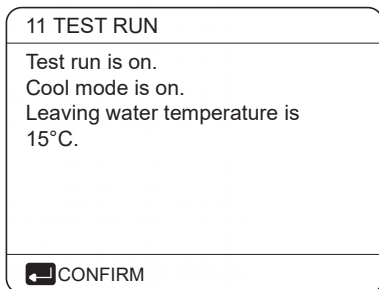

During COOL MODE test running, the default target outlet water temperature is 7°C. The unit will operate until the water temperature drops to a certain value or the next command is received.

When the HEAT MODE RUNNING is selected, the following page will be displayed:

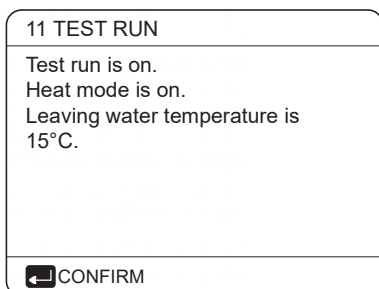

During HEATMODEtest running , the default target outlet water temperature is 35°C. The IBH (internal backup heater) will turn on after the compressor runs for 10 min. After the IBH runs for 3 minutes, the IBH will turn off, the heat pump will operate until the water temperature increase to a certain value or the next command is received.

When the DHW MODE RUNNING is selected, the following page will be displayed:

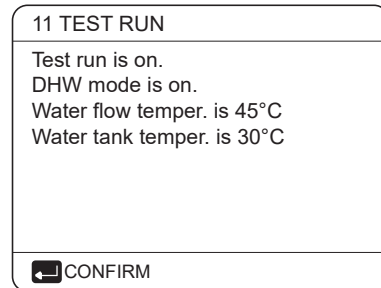

During DHW MODE test running, the default target temperature of the domestic water is 55°C. The TBH(tank boost heater) will turn on after the compressor runs for 10min. The TBH will turn off 3 minutes later, the heat pump will operate until the water temperature increase to a certain value or the next command is received.

During test run, all buttons except are invalid. If you want to turn off the test run, please press . For example ,when the unit is in air purge mode, after you press , the following page will be displayed:

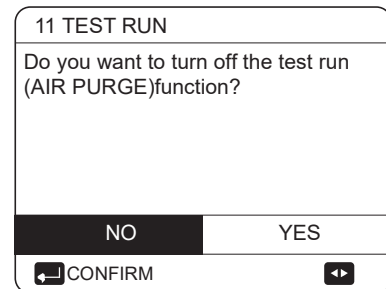

Press to scroll the cursor to YES and press . The test run will turn off.

8.4.12 SPECIAL FUNCTION

When it is in special function modes,the wired controller can not operate, the page do not return to the homepage, and the screen showed the page that special function runs, the wired controller do not locked.

NOTE

During special function operating other functions (WEEKLY SCHEDULE/TIMER , HOLIDAY AWAY, HOLIDAY HOME) can't be used.

Go to > FOR SERVICEMAN> 12.SPECIAL FUNCTION.

Before floor heating, if a large amount of water remains on the floor, the floor may be warped or even rupture during floor heating operation, in order to protect the floor, floor drying is necessary, during which the temperature of the floor should be increased gradually.

12 SPECIAL FUNCTION	
Active the settings and active the "SPECIAL FUNCTION"?	
NO	YES
← CONFIRM	→

12 SPECIAL FUNCTION	
12.1 PREHEATING FOR FLOOR	
12.2 FLOOR DRYING UP	
← ENTER	↓

Press ▼ ▲ to scroll and press ↵ to enter.

During first operation of the unit, air may remain in the water system which can cause malfunctions during operation. It is necessary to run the air purge function to release the air (make sure the air purge valve is open).

If PREHEATING FOR FLOOR is selected, after press ↵, the following page will be displayed:

12.1 PREHEATING FOR FLOOR	
T1S	30°C
t_fristFH	72 HOURS
ENTER	EXIT
↓ ADJUST	→

When the cursor is on OPERATE PREHEATING FOR FLOOR, Use ◀ ▶ to scroll to YES and press ↵. The following page will be displayed:

12.1 PREHEATING FOR FLOOR	
Preheat for floor is running for 25 minutes. Water flow temperature is 20°C.	
← CONFIRM	

During preheating for floor, all the buttons except ↵ are invalid. If you want to turn off the preheating for floor, please press ↵.

The following page will be displayed:

12.1 PREHEATING FOR FLOOR	
Do you want to turn off the preheating for floor function?	
NO	YES
← CONFIRM	→

Use ◀ ▶ to scroll the cursor to YES and press ↵, the preheating for floor will turn off.

The operation of the unit during preheating for floor described in the picture below:

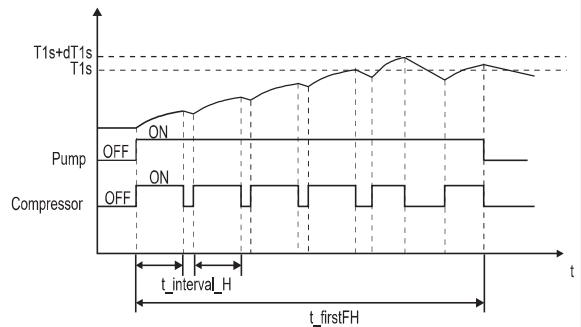

If FLOOR DRYING UP is selected, after pressing ↵, the following pages will be displayed:

12.2 FLOOR DRYING UP	
WARM UP TIME(t_DRYUP)	8 days
KEEP TIME(t_HIGHPEAK)	5 days
TEMP. DOWN TIME(t_DRYDOWN)	5 days
PEAK TEMP.(T_DRYPEAK)	45°C
START TIME	15:00
↓ ADJUST	→

12.2 FLOOR DRYING UP	
START DATE	01-01-2019
ENTER	EXIT
↓ ADJUST	→

During floor drying, all the buttons except are invalid. When the heat pump malfunctions, the floor drying mode will turn off when the backup heater and additional heating source is unavailable. If you want to turn off floor drying up, please press . The following page will be displayed:

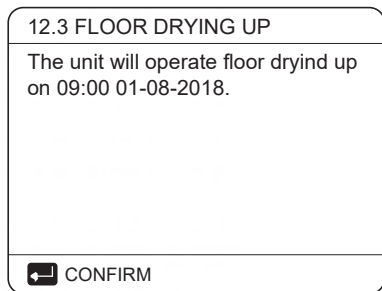

Use ◀ ▶ to scroll the cursor to YES and press ↵. Floor drying will turn off.

The target outlet water temperature during floor drying up described in the picture below:

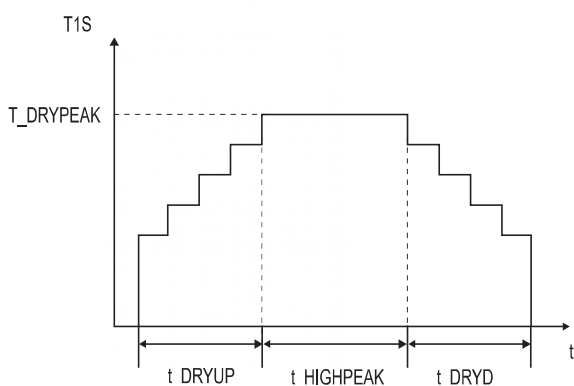

8.4.13 AUTO RESTART

The AUTO RESTART function is used to select whether the unit reapplies the user interface settings at the time when power returns after a power supply failure.

Go to [Menu] > FOR SERVICEMAN>13.AUTO RESTART

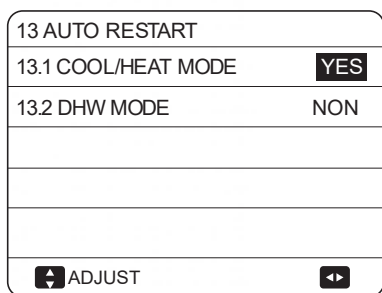

The AUTO RESTART function reapplies the user interface settings at the time of the power supply failure. If this function is disabled, when power returns after a power supply failure, the unit won't auto restart.

8.4.14 POWER INPUT LIMITATION

How to set the POWER INPUT LIMITATION

Go to [Menu] > FOR SERVICEMAN> 14.POWER INPUT LIMITATION

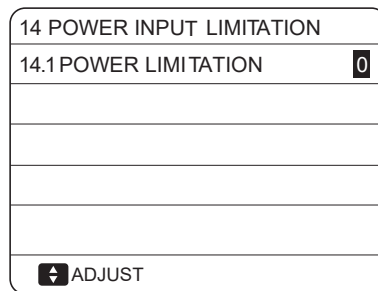

8.4.15 INPUT DEFINE

How to set the INPUT DEFINE

Go to [Menu] > FOR SERVICEMAN> 15.INPUT DEFINE

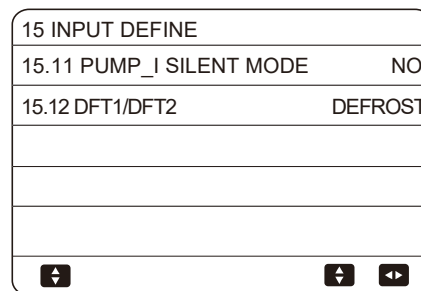
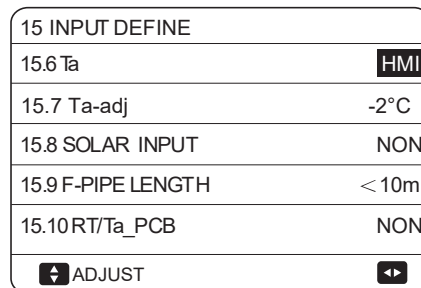
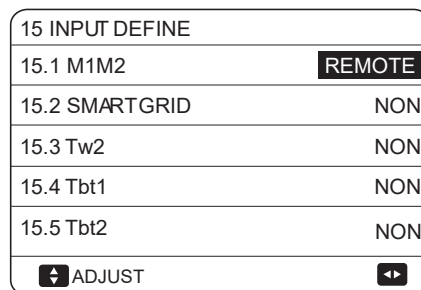

8.4.16 SETTING PARAMETERS

The parameters related to this chapter are shown in the table below.

Order number	Code	State	Default	Minumum	Maximum	Setting interval	Unit
1.1	DHW MODE	Enable or disable the DHW mode:0=NON,1=YES	1	0	1	1	/
1.2	DISINFECT	Enable or disable the disinfect mode:0=NON,1=YES	1	0	1	1	/
1.3	DHW PRIORITY	Enable or disable the DHW priority mode:0=NON,1=YES	1	0	1	1	/
1.4	PUMP_D	Enable or disable the DHW pump mode:0=NON,1=YES	0	0	1	1	/
1.5	DHW PRIORITY TIME SET	Enable or disable the DHW priority time set:0=NON,1=YES	0	0	1	1	/
1.6	dT5_ON	The temperature difference for starting the heat pump	10	1	30	1	°C
1.7	dT1S5	The difference value between Twout and T5 in DHW mode	10	5	40	1	°C
1.8	T4DHWMAX	The maximum ambient temperature that the heat pump can operate at for domestic water heating	43	35	43	1	°C
1.9	T4DHWMIN	The minimum ambient temperature that the heat pump can operate for domestic water heating	-10	-25	30	1	°C
1.10	t_INTERVAL_DHW	the start time interval of the compressor in DHW mode.	5	5	5	1	MIN
1.11	dT5_TBH_OFF	the temperature difference between T5 and T5S that turns the booster heater off.	5	0	10	1	°C
1.12	T4_TBH_ON	the highest outdoor temperature the TBH can operate.	5	-5	50	1	°C
1.13	t_TBH_DELAY	the time that the compressor has run before starting the booster heater	30	0	240	5	MIN
1.14	T5S_DISINFECT	the target temperature of water in the domestic hot water tank in the DISINFECT function.	65	60	70	1	°C
1.15	t_DI_HIGHTEMP.	the time that the highest temperature of water in the domestic hot water tank in the DISINFECT function will last	15	5	60	5	MIN
1.16	t_DI_MAX	the maximum time that disinfection will last	210	90	300	5	MIN
1.17	t_DHWHP_RESTRICT	he operation time for the space heating/cooling operation.	30	10	600	5	MIN
1.18	t_DHWHP_MAX	the maximum continuous working period of the heat pump in DHW PRIORITY mode.	90	10	600	5	MIN
1.19	PUMP_D TIMER	Enable or disable the DHW pump run as timed and keeps running for PUMP RUNNING TIME:0=NON,1=YES	1	0	1	1	/
1.20	PUMP_D RUNNING TIME	the certain time that the DHW pump will keep running for	5	5	120	1	MIN
1.21	PUMP_D DISINFECT RUN	Enable or disable the DHW pump operate when the unit is in disinfect mode and T5: T5S_DI-2:0=NON,1=YES	1	0	1	1	/
2.1	COOL MODE	Enable or disable the cooling mode:0=NON,1=YES	1	0	1	1	/
2.2	t_T4_FRESH_C	The refresh time of climate related curves for cooling mode	0.5	0.5	6	0.5	hours
2.3	T4CMAX	The highest ambient operation temperature for cooling mode	52	35	52	1	°C
2.4	T4CMIN	the lowest ambient operating temperature for cooling mode	10	-5	25	1	°C
2.5	dT1SC	the temperature difference for starting the heat pump(T1)	5	2	10	1	°C
2.6	dTSC	the temperature difference for starting the heat pump(Ta)	2	1	10	1	°C
2.7	t_INTERVAL_COOL	the start time interval of the compressor in COOL mode	5	5	5	1	°C
2.8	T1SetC1	The setting temperature 1 of climate related curves for cooling mode.	10	5	25	1	MIN
2.9	T1SetC2	The setting temperature 2 of climate related curves for cooling mode.	16	5	25	1	°C
2.10	T4C1	The ambient temperature 1 of climate related curves for cooling mode.	35	-5	46	1	°C
2.11	T4C2	The ambient temperature 2 of climate related curves for cooling mode.	25	-5	46	1	°C
2.12	ZONE1 C-EMISSION	The type of zone1 end for cooling mode 0=FCU(fan coil unit), 1=RAD.(radiator), 2=FLH(floor heating)	0	0	2	1	/
2.13	ZONE2 C-EMISSION	The type of zone2 end for cooling mode 0=FCU(fan coil unit), 1=RAD.(radiator), 2=FLH(floor heating)	0	0	2	1	/

3.1	HEAT MODE	Enable or disable the heating mode	1	0	1	1	/
3.2	t_T4_FRESH_H	The refresh time of climate related curves for heating mode	0.5	0.5	6	0.5	hours
3.3	T4HMAX	The maximum ambient operating temperature for heating mode	25	20	35	1	°C
3.4	T4HMIN	The minimum ambient operating temperature for heating mode	-15	-25	30	1	°C
3.5	dT1SH	The temperature difference for starting the unit (T1)	5	2	20	1	°C
3.6	dTSH	The temperature difference for starting the unit (Ta)	2	1	10	1	°C
3.7	t_INTERVAL_HEAT	the start time interval of the compressor in HEAT mode	5	5	5	1	MIN
3.8	T1SetH1	The setting temperature 1 of climate related curves for heating mode	35	25	65	1	°C
3.9	T1SetH2	The setting temperature 2 of climate related curves for heating mode	28	25	65	1	°C
3.10	T4H1	The ambient temperature 1 of climate related curves for heating mode	-5	-25	35	1	°C
3.11	T4H2	The ambient temperature 2 of climate related curves for heating mode	7	-25	35	1	°C
3.12	ZONE1 H-EMISSION	The type of zone1 end for heating mode : 0=FCU(fan coil unit), 1=RAD.(radiator), 2=FLH(floor heating)	1	0	2	1	/
3.13	ZONE2 H-EMISSION	The type of zone2 end for heating mode : 0=FCU(fan coil unit), 1=RAD.(radiator), 2=FLH(floor heating)	2	0	2	1	/
3.14	t_DELAY_PUMP	The delay time for water pump to stop after the compressor stops	2	0.5	20	0.5	MIN
4.1	T4AUTOCMIN	The minimum operating ambient temperature for cooling in auto mode	25	20	29	1	°C
4.2	T4AUTOHMAX	The maximum operating ambient temperature for heating in auto mode	17	10	17	1	°C
5.1	WATER FLOW TEMP.	Enable or disable the WATER FLOW TEMP.:0=NON,1=YES	1	0	1	1	/
5.2	ROOM TEMP.	Enable or disable the ROOM TEMP.:0=NON,1=YES	0	0	1	1	/
5.3	DOUBLE ZONE	Enable or disable the ROOM THERMOSTAT DOUBLE ZONE:0=NON,1=YES	0	0	1	1	/
6.1	ROOM THERMOSTAT	The style of room thermostat 0=NON,1=MODE SET,2=ONE ZONE,3=DOUBLE ZONE	0	0	3	1	/
7.1	dT1_IBH_ON	The temperature difference between T1S and T1 for starting the backup heater.	5	2	10	1	°C
7.2	t_IBH_DELAY	The time that the compressor has run before the first backup heater turns on	30	15	120	5	MIN
7.3	T4_IBH_ON	The ambient temperature for starting the backup heater	-5	-15	30	1	°C
7.4	dT1_AHS_ON	The temperature difference between T1S and T1 for turning the additional heating source on	5	2	20	1	°C
7.5	t_AHS_DELAY	The time that the compressor has run before starting the additional heating source	30	5	120	5	MIN
7.6	T4_AHS_ON	The ambient temperature for starting the additional heating source	-5	-15	30	1	°C
7.7	IBH_LOCATE	IBH/AHS installation location PIPE LOOP=0; BUFFER TANK=1	0	0	0	0	°C
7.8	P_IBH1	Power input of IBH1	0	0	20	0.5	kW
7.9	P_IBH2	Power input of IBH2	0	0	20	0.5	kW
7.10	P_TBH	Power input of TBH	2	0	20	0.5	kW
8.1	T1S_HA_H	The target outlet water temperature for space heating when in holiday away mode	25	20	25	1	°C
8.2	T5S_HA_DHW	The target outlet water temperature for domestic hot water heating when in holiday away mode	25	20	25	1	°C
12.1	PREHEATING FOR FLOOR T1S	The setting temperature of outlet water during first preheating for floor	25	25	35	1	°C
12.3	t_FIRSTFH	The time last for preheating floor	72	48	96	12	HOURL

12.4	t_DRYUP	The day for warming up during floor drying up	8	4	15	1	DAY
12.5	t_HIGHPEAK	The continue days in high temperature during floor drying up	5	3	7	1	DAY
12.6	t_DRYD	The day of dropping temperature during floor drying up	5	4	15	1	DAY
12.7	T_DRY PEAK	The target peak temperature of water flow during floor drying up	45	30	55	1	°C
12.8	START TIME	The start time of floor drying up	Hour: the present time(not on the hour +1, on the hour +2) Minute:00	0:00	23:30	1/30	h/min
12.9	START DATE	The start date of floor drying up	The present date	1/1/2000	31/12/2099	1/1/2001	d/m/y
13.1	AUTO RESTART COOL/HEAT MODE	Enable or disable the auto restart cooling/heating mode. 0=NON,1=YES	1	0	1	1	/
13.2	AUTO RESTART DHW MODE	Enable or disable the auto restart DHW mode. 0=NON,1=YES	1	0	1	1	/
14.1	POWER INPUT LIMITATION	The type of power input limitation, 0=NON, 1~8=TYPE 1~8	0	0	8	1	/
15.1	M1 M2	Define the function of the M1M2 switch; 0= REMOTE ON/OFF, 1= TBH ON/OFF, 2= AHS ON/OFF	0	0	2	1	/
15.2	SMART GRID	Enable or disable the SMART GRID; 0=NON,1=YES	0	0	1	1	/
15.3	Tw 2	Enable or disable the T1b(Tw 2) ; 0=NON,1=YES	0	0	1	1	/
15.4	Tbt1	Enable or disable the Tbt1; 0=NON,1=YES	0	0	1	1	/
15.5	Tbt2	Enable or disable the Tbt2; 0=NON,1=YES	0	0	1	1	/
15.6	Ta	Enable or disable the Ta; 0=NON,1=YES	0	0	1	1	/
15.7	Ta-adj	The corrected value of Ta on wired controller	-2	-10	10	1	°C
15.8	SOLAR INPUT	Choose the SOLAR INPUT; 0=NON,1=CN18Tsolar,2=CN11SL1SL2	0	0	2	1	/
15.9	F-PIPE LENGTH	Choose the total length of the liquid pipe(F-PIPE LENGTH); 0=F-PIPE LENGTH< 10m,1=F-PIPE LENGTH≥ 10m	0	0	1	1	/
15.10	RT/Ta_PCB	Enable or disable the RT/Ta_PCB; 0=NON,1=YES	0	0	1	1	/
15.11	PUMP_I SILENT MODE	Enable or disable PUMPI SILENT MODE 0=NON, 1=YES	0	0	1	1	/
15.12	DFT1/DFT2	DFT1/DFT2 port function:0=DEFROST 1=ALARM	0	0	1	1	/
16.1	PER_START	Start-up percentage of multiple units	10	10	100	10	%
16.2	TIME_ADJUST	Adjustment time of adding and subtracting units	5	1	60	1	MIN
16.3	ADDRESS RESET	Reset the address code of the unit	FF	0	15	1	/
17.1	HMI SET	Choose the HMI; 0=MASTER,1=SLAVE	0	0	1	1	/
17.2	HMI ADDRESS FOR BMS	Set the HMI address code for BMS	1	1	16	1	/
17.3	STOP BIT	HMI stop bit	1	1	2	1	/

 **NOTE**

15.12 DFT1/DFT2 ALARM function can be valid only with IDU software version higher than V99.

9 TEST RUN AND FINAL CHECKS

The installer is obliged to verify correct operation of unit after installation.

9.1 Final checks

Before switching on the unit, read following recommendations:

- When the complete installation and all necessary settings have been carried out, close all front panels of the unit and refit the unit cover.
- The service panel of the switch box may only be opened by a licensed electrician for maintenance purposes.

9.2 Test run operation (manually)

If required, the installer can perform a manual test run operation at any time to check correct operation of air purge, heating, cooling and domestic water heating, refer to 8.4.11 "TEST RUN" .

10 MAINTENANCE AND SERVICE

In order to ensure optimal availability of the unit, a number of checks and inspections on the unit and the field wiring have to be carried out at regular intervals.

This maintenance needs to be carried out by your local technician.

In order to ensure optimal availability of the unit, a number of checks and inspections on the unit and the field wiring have to be carried out at regular intervals.

This maintenance has to be carried out by your local technician.

DANGER

ELECTRIC SHOCK

- Before carrying out any maintenance or repairing activity, must switch off the power supply on the supply panel.
 - Do not touch any live part for 10 minutes after the power supply is turned off.
 - The crank heater of compressor may operate even in standby.
 - Please note that some sections of the electric component box are hot.
 - Forbid touch any conductive parts.
 - Forbid rinse the unit. It may cause electric shock or fire.
- Forbid leave the unit unattended when service panel is removed.

The following checks must be performed at least once a year by qualified person.

- Water pressure
Check the water pressure, if it is below 1 bar, fill water to the system.
- Water filter
Clean the water filter.
- Water pressure relief valve
Check for correct operation of the pressure relief valve by turning the black knob on the valve counter-clockwise:
If you do not hear a clacking sound, contact your local dealer.
In case the water keeps running out of the unit, close both the water inlet and outlet shut-off valves first and then contact your local dealer.
- Pressure relief valve hose
Check that the pressure relief valve hose is positioned appropriately to drain the water.
- Backup heater vessel insulation cover
Check that the backup heater insulation cover is fastened tightly around the backup heater vessel.
- Domestic hot water tank pressure relief valve (field supply).
Check for correct operation of the pressure relief valve on the domestic hot water tank.
- Unit switch box
Carry out a thorough visual inspection of the switch box and look for obvious defects such as loose connections or defective wiring.
Check for correct operation of contactors with an ohm meter. All contacts of these contactors must be in open position.

11 TECHNICAL SPECIFICATIONS

Indoor unit model	100/190 3kW heater	100/240 3kW heater	160/240 3kW heater
Power supply	220-240V~ 50Hz		
Rated input	3095W		
Rated Current	13.5A		
Normal capacity	Refer to the technical data		
Dimensions (W×H×D)[mm]	600*1683*600	600*1943*600	
Packing (W×H×D)[mm]	730*1920*730	730*2180*730	
Heat exchanger	Plate heat exchanger		
Electric heater	3000W		
Internal water volume	13.5L		
Rated water pressure	0.3MPa		
Filter mesh	60		
Min. water flow (flow switch)	6L/min	10L/min	
Pump			
Type	DC inverter		
Max. head	9m		
Power input	5~90W		
Expansion vessel			
Volume	8L		
Max. operating pressure	0.3MPa		
Pre-charge pressure	0.10MPa		
Weight			
Net weight	140kg	157kg	159kg
Gross weight	161kg	178kg	180kg
Connections			
Refrigerant pipe(gas/liquid)	Φ15.9/Φ9.52		
Water inlet/outlet	R1"		
Drain connection	Φ25		
Operation range			
Outlet water(heating model)	+12 ~ +65 °C		
Outlet water(cooling model)	+5 ~ +30 °C		
Domestic hot water	+12 ~ +60 °C		
Space heating/cooling water inlet water pressure	0.1~0.25MPa		
Domestic cold water pressure	0.15~0.3MPa		
Ambient temperature(Indoor side)	+5 ~ +35 °C		

Indoor unit model	100/190 6kW heater	100/240 6kW heater	160/240 6kW heater	100/190 9kW heater	100/240 9kW heater	160/240 9kW heater
Power supply	220-240V~ 50Hz			380~415V 3N~ 50Hz		
Rated input	6095W			9095W		
Rated Current	26.5A			13.5A		
Norminal capacity	Refer to the technical data					
Dimensions (W×H×D)[mm]	600*1683*600	600*1943*600		600*1683*600	600*1943*600	
Packing (W×H×D)[mm]	730*1920*730	730*2180*730		730*1920*730	730*2180*730	
Heat exchanger	Plate heat exchanger					
Electric heater	6000W			9000W		
Internal water volume	13.5L					
Rated water pressure	0.3MPa					
Filter mesh	60					
Min. water flow (flow switch)	6L/min		10L/min	6L/min		10L/min
Pump						
Type	DC inverter					
Max. head	9m					
Power input	5~90W					
Expansion vessel						
Volume	8L					
Max. operating pressure	0.3MPa					
Pre-charge pressure	0.10MPa					
Weight						
Net weight	140kg	157kg	159kg	140kg	157kg	159kg
Gross weight	161kg	178kg	180kg	161kg	178kg	180kg
Connections						
Refrigerant pipe(gas/liquid)	Φ15.9/Φ9.52					
Water inlet/outlet	R1"					
Drain connection	Φ25					
Operation range						
Outlet water(heating model)	+12~+65℃					
Outlet water(cooling model)	+5~+30℃					
Domestic hot water	+12~+60℃					
Space heating/cooling water inlet water pressure	0.1~0.25MPa					
Domestic cold water pressure	0.15~0.3MPa					
Ambient temperature (Indoor side)	+5~+35℃					

12 ERROR CODES

When a safety device is activated, an error code will be displayed on the user interface.

A list of all errors and corrective actions can be found in the table below.

Reset the safety by turning the unit OFF and back ON.

In case this procedure for resetting the safety is not successful, contact your local dealer.

ERROR CODE	MALFUNCTION OR PROTECTION	FAILURE CAUSE AND CORRECTIVE ACTION
<i>E0</i>	Water flow fault(after 3 times E8)	<ol style="list-style-type: none"> 1.The wire circuit is short connected or open. Reconnect the wire correctly. 2.Water flow rate is too low. 3. Water flow switch is failed, switch is open or close continuously, change the water flow switch.
<i>E2</i>	Communication fault between controller and indoor unit	<ol style="list-style-type: none"> 1.Wire doesn't connect between wired controller and unit. connect the wire. 2.Communication wire sequence is not right. Reconnect the wire in the right sequence. 3.Whether there is a high magnetic field or high power interfere, such as lifts, large power transformers, etc.. <p>To add a barrier to protect the unit or to move the unit to the other place.</p>
<i>E3</i>	Final outlet water temp.sensor(T1) fault	<ol style="list-style-type: none"> 1.Check the resistance of the sensor 2.The T1 sensor connector is loosen. Reconnect it. 3.The T1 sensor connector is wet or there is water in. remove the water, make the connector dry. Add waterproof adhesive. 4.The T1 sensor failure, change a new sensor.
<i>E4</i>	water tank temp.sensor (T5) fault	<ol style="list-style-type: none"> 1.Check the resistance of the sensor 2.The T5 sensor connector is loosen. Reconnect it. 3.The T5 sensor connector is wet or there is water in. remove the water, make the connector dry. Add waterproof adhesive 4.The T5 sensor failure, change a new sensor. 5.If you want to close the domestic water heating when T5 sensor do not connected to the system, then T5 sensor can not be detected, refer to 8.4.1 "DHW MODE SETTING"
<i>E8</i>	Water flow failure	<p>Check that all shut off valves of the water circuit are completely open.</p> <ol style="list-style-type: none"> 1. Check if the water filter needs cleaning. 2. Refer to "6.8 Filling water" 3. Make sure there is no air in the system(purge air). 4. Check on the manometer that there is sufficient water pressure. The water pressure must be >1 bar. 5. Check that the pump speed setting is on the highest speed. 6. Make sure that the expansion vessel is not broken. 7. Check that the resistance in the water circuit is not too high for the pump. 8. If this error occurs at defrost operation (during space heating or domestic water heating), make sure that the backup heater power supply is wired correctly and that fuses are not blown. 9. Check that the pump fuse and PCB fuse are not blown.
<i>Ed</i>	Inlet water temp.sensor (Tw_in) malfunction	<ol style="list-style-type: none"> 1.Check the resistance of the sensor 2. The Tw_in sensor connector is loosen. Re connect it. 3.The Tw_in sensor connector is wet or there is water in. remove the water, make the connector dry. Add waterproof adhesive 4. The Tw_in sensor failure, change a new sensor.

ERROR CODE	MALFUNCTION OR PROTECTION	FAILURE CAUSE AND CORRECTIVE ACTION
<i>EE</i>	Indoor unit EEPROM failure	<ol style="list-style-type: none"> 1. The EEPROM parameter is error, rewrite the EEPROM data. 2. EEPROM chip part is broken, change a new EEPROM chip part. 3. main control board of indoor unit is broken, change a new PCB.
<i>H0</i>	Communication fault between indoor unit and outdoor unit	<ol style="list-style-type: none"> 1. wire doesn't connect between outdoor unit and main control board of indoor unit. connect the wire. 2. Communication wire sequence is not right. Reconnect the wire in the right sequence. 3. Whether there is a high magnetic field or high power interfere, such as lifts, large power transformers, etc.. To add a barrier to protect the unit or to move the unit to the other place.
<i>H2</i>	Refrigerant liquid temp.sensor(T2) fault	<ol style="list-style-type: none"> 1. Check the resistance of the sensor 2. The T2 sensor connector is loosen. Re connect it. 3. The T2 sensor connector is wet or there is water in. remove the water, make the connector dry. Add waterproof adhesive 4. The T2 sensor failure, change a new sensor.
<i>H3</i>	Refrigerant gas temp.sensor(T2B) fault	<ol style="list-style-type: none"> 1. Check the resistance of the sensor 2. The T2B sensor connector is loosen. Reconnect it. 3. The T2B sensor connector is wet or there is water in. remove the water, make the connector dry. Add waterproof adhesive 4. The T2B sensor failure, change a new sensor.
<i>H5</i>	Room temp.sensor(Ta) fault	<ol style="list-style-type: none"> 1. Check the resistance of the sensor 2. The Ta sensor is in the interface; 3. The Ta sensor failure, change a new sensor or change a new interface, or reset the Ta, connect a new Ta from the indoor unit PCB
<i>H9</i>	Outlet water for zone 2 temp.sensor (Tw2) fault	<ol style="list-style-type: none"> 1. Check the resistance of the sensor 2. The T1B sensor connector is loosen. Reconnect it. 3. The T1B sensor connector is wet or there is water in. Remove the water, make the connector dry. add waterproof adhesive 4. The T1B sensor failure, change a new sensor.
<i>HR</i>	Outlet water temp.sensor(Tw_out) fault	<ol style="list-style-type: none"> 1. The TW_out sensor connector is loosen. Reconnect it. 2. The TW_out sensor connector is wet or there is water in. remove the water, make the connector dry. add waterproof adhesive 3. The TW_out sensor failure, change a new sensor.
<i>PS</i>	Tw_out - Tw_in value too big protection	<ol style="list-style-type: none"> 1. Check that all shut off valves of the water circuit are completely open. 2. Check if the water filter needs cleaning. 3. Refer to "6.8 Filling water" 4. Make sure there is no air in the system (purge air). 5. Check on the manometer that there is sufficient water pressure. The water pressure must be >1 bar(water is cold). 6. Check that the pump speed setting is on the highest speed. 7. Make sure that the expansion vessel is not broken. 8. Check that the resistance in the water circuit is not too high for the pump.
<i>Pb</i>	Anti-freeze mode	Unit will return to the normal operation automatically.
<i>PP</i>	Tw_out - Tw_in unusual protection	<ol style="list-style-type: none"> 1. Check the resistance of the two sensor 2. Check the two sensors locations 3. The water inlet/outlet sensor wire connector is loosen. Reconnect it. 4. The water inlet/outlet (TW_in /TW_out) sensor is broken, Change a new sensor. 5. Four-way valve is blocked. Restart the unit again to let the valve change the direction. 6. Four-way valve is broken, change a new valve.

ERROR CODE	MALFUNCTION OR PROTECTION	FAILURE CAUSE AND CORRECTIVE ACTION
<i>Hb</i>	Three times "PP" protection and Tw_out < 7°C	The same to "PP".
<i>E7</i>	Buffer tank up temp.sensor(Tbt1) fault	<ol style="list-style-type: none"> 1.Check the resistance of the sensor. 2.The Tbt1 sensor connector is loosen,reconnect it. 3.The Tbt1 sensor connector is wet or there is water in,remove the water ,make the connector dry.Add waterproof adhesive. 4.The Tbt1 sensor failure,change a new sensor."
<i>Eb</i>	Solar temp.sensor(Tsolar) fault	<ol style="list-style-type: none"> 1.Check the resistance of the sensor. 2.The Tsolar sensor connector is loosen,reconnect it. 3.The Tsolar sensor connector is wet or there is water in,remove the water ,make the connector dry.Add waterproof adhesive. 4.The Tsolar sensor failure,change a new sensor."
<i>Ec</i>	Buffer tank low temp.sensor(Tbt2) fault	<ol style="list-style-type: none"> 1.Check the resistance of the sensor. 2.The Tbt2 sensor connector is loosen,reconnect it. 3.The Tbt2 sensor connector is wet or there is water in,remove the water ,make the connector dry.Add waterproof adhesive. 4.The Tbt2 sensor failure,change a new sensor."
<i>HE</i>	Communication error between main board and thermostat transferboard	<p>RT/Ta PCB is set to be valid on user interface but the thermostat transfer board is not connected or the communication between thermostat transfer board and main board is not effectively connected. If the thermostat transfer board is not needed , set the RT/Ta PCB to invalid. If the thermostat transfer board is needed , please connect it to the main board and make sure the communication wire is connected well and there is no strong electricity or strong magnetic interference.</p>

 **CAUTION**

- In winter, if the unit has E0 and Hb failure and the unit is not repaired in time, the water pump and pipeline system may be damaged by freezing, so E0 and Hb failure must be repaired in time.

ANNEX A: Refrigerant cycle

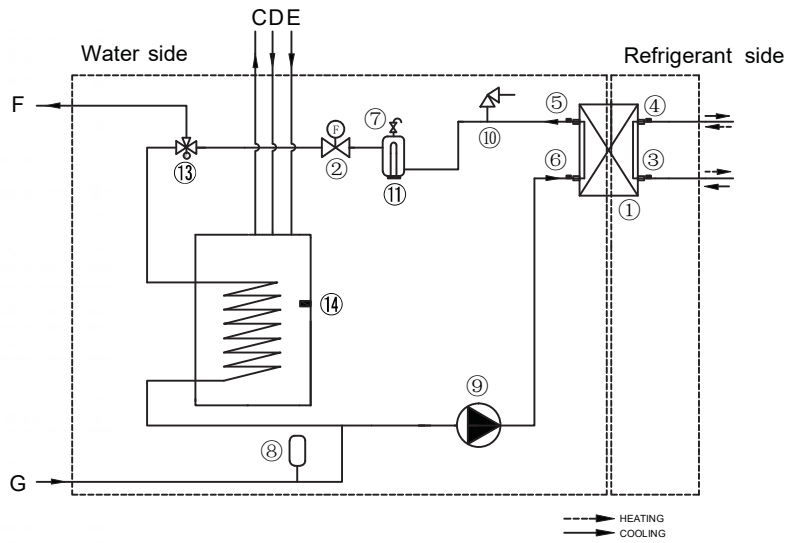

Standard Unit

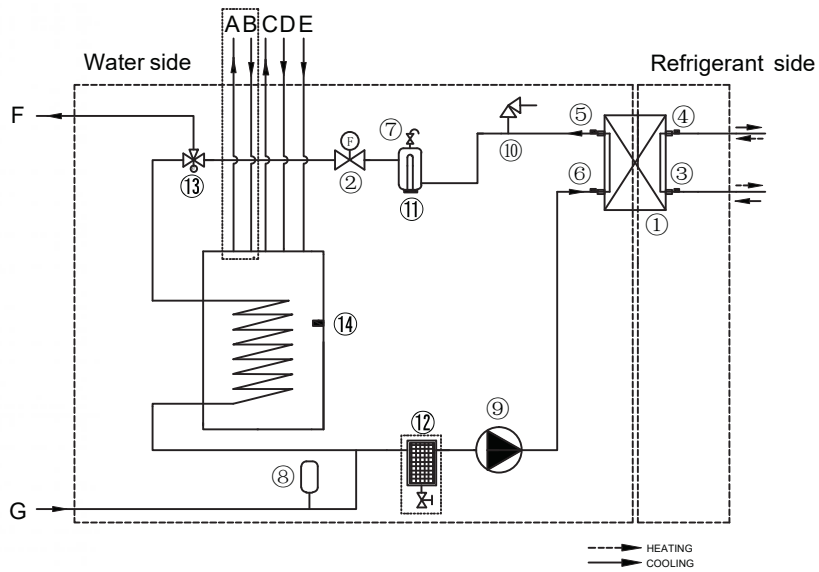

Optional Unit

Item	Description	Item	Description
1	Water side heat exchanger (Plate heat exchange)	12	Magnetic separator (Optional)
2	Flow switch	13	3-Way valve
3	Refrigerant liquid line temperature sensor	14	Domestic water tank temperature sensor
4	Refrigerant gas line temperature sensor		
5	Water outlet temperature sensor	A	Solar circulation outlet (Optional)
6	Water inlet temperature sensor	B	Solar circulation inlet (Optional)
7	Automatic air purge valve	C	Domestic hot water outlet
8	Expansion vessel	D	Domestic hot water recirculation inlet
9	Circulated pump	E	Domestic cold water inlet
10	Pressure relief valve	F	Space heating/cooling water outlet
11	Backup heater	G	Space heating/cooling water inlet

EN

For downloading manual for this product, please enter the model name at this link:

**CZ**

Pro stažení manuálu k tomuto produktu zadejte modelové označení do následujícího odkazu:

**SK**

Pre stiahnutie manuálu k tomuto produktu zadajte modelové označenie do nasledujúceho odkazu:

**DE**

Um das Handbuch für dieses Produkt herunterzuladen, geben Sie bitte den Modellnamen für diesen Link ein:

**HR**

Za preuzimanje priručnika za ovaj proizvod unesite naziv modela na ovu vezu:

**HU**

Termék kézikönyvének letöltéséhez írja be a modell megnevezését az alábbi linkre:

**SL**

Za prenos navodil za uporabo tega izdelka, vnesite ime modela na tej povezavi:

**RU**

Чтобы загрузить руководство для этого продукта, введите обозначение модели по следующей ссылке:

**IT**

Per scaricare il manuale di questo prodotto, inserisci il nome del modello a questo link:

**ES**

Para descargar el manual de este producto, ingrese la designación del modelo en el siguiente enlace:



NOTE CONCERNING PROTECTION OF ENVIRONMENT



This product must not be disposed of via normal household waste after its service life, but must be taken to a collection station for the recycling of electrical and electronic devices. The symbol on the product, the operating instructions or the packaging indicate such disposal procedures. The materials are recyclable in accordance with their respective symbols. By means of re-use, material recycling or any other form of recycling old appliances you are making an important contribution to the protection of our environment. Please ask your local council where your nearest disposal station is located.

INFORMATION CONCERNING USED REFRIGERANT MEDIUM

This unit is containing fluorinated gases included in the Kyoto protocol.
The maintenance and the liquidation must be carried out by qualified personnel.

Type of refrigerant: R32

The quantity of the refrigerant: Please see the unit label.

The value GWP: 675 (1 kg R32 = 0,675 t CO₂ eq)

GWP = Global Warming Potential



Appliance filled with flammable gas R32.

In case of quality problem or other please contact your local supplier or authorized service center.

Emergency number: 112

PRODUCER

SINCLAIR CORPORATION Ltd.

16 Great Queen Street

WC2B 5AH London

United Kingdom

www.sinclair-world.com

This product was manufactured in China (Made in China).

REPRESENTATIVE

SINCLAIR Global Group s.r.o.

Purkynova 45

612 00 Brno

Czech Republic

TECHNICAL SUPPORT

SINCLAIR Global Group s.r.o.

Purkynova 45

612 00 Brno

Czech Republic

Tel.: +420 800 100 285 | Fax: +420 541 590 124

www.sinclair-solutions.com | info@sinclair-solutions.com



