

**ECO**<sup>TM</sup> heat transfer  
coolers

**MODINE**<sup>®</sup>



**GCE**

**MANUALE TECNICO**

Aeroevaporatori a soffitto

**BETRIEBSANLEITUNG**

Deckenluftverdampfer

**TECHNICAL MANUAL**

Ceiling unit coolers

**MANUAL TECNICO**

Aeroevaporadores de techo

**MANUEL TECHNIQUE**

Evaporateurs plafonniers

**ТЕХНИЧЕСКОЕ РУКОВОДСТВО**

Потолочные воздухоохладители





## GCE

### Indice

- Avvertenze .....	2
- Ispezione - Trasporto .....	2
- Condizioni da verificare per una corretta messa in opera .....	2
- Manutenzione generale .....	2
- Pericoli .....	2
- Norme di riferimento .....	2
- Avvertenze per una corretta installazione .....	3
- Caratteristiche costruttive e dimensionali .....	3
- Schema di collegamento dei motoventilatori .....	5
- Suggerimenti per un corretto accesso all'apparecchio .....	6
- Schema di collegamento e potenze delle resistenze elettriche .....	6
- Garanzie .....	51

### Index

- Hinweise .....	10
- Kontrolle - Transport .....	10
- Hinweise für eine korrekte Inbetriebnahme .....	10
- Allgemeine Wartung .....	10
- Gefahren .....	10
- Bezugsnormen .....	10
- Hinweise für eine korrekte Aufstellung .....	11
- Konstruktionseigenschaften und Abmessungen .....	11
- Anschlußplan der Motorventilatoren .....	13
- Ratschläge für einen korrekten Zugang zum Gerät .....	14
- Anschlußplan und Leistungen der Heizstäbe .....	14
- Gewährleistung .....	51

### Index

- Important .....	18
- Inspection - Transport .....	18
- For a proper installation .....	18
- General maintenance .....	18
- Hazards / Risks .....	18
- Reference standards .....	18
- Instructions for a correct installation .....	19
- Manufacturing and dimensional features .....	19
- Fan motor connection scheme .....	21
- Recommendations for a proper access to model .....	22
- Electric heater connection schemes and electric power .....	22
- Warranty .....	51

### Indice

- Advertencias .....	26
- Inspección - Transporte .....	26
- Condiciones a verificar para una correcta puesta en marcha .....	26
- Manutención general .....	26
- Peligros .....	26
- Normas de referencia .....	26
- Advertencias para una correcta instalación .....	27
- Características constructivas y dimensionales .....	27
- Esquema de conexión motoventiladores .....	29
- Sugerencias para un correcto acceso al aparato .....	30
- Esquema de conexión y potencia de las resistencias eléctricas .....	30
- Garantías .....	51

### Index

- Attention .....	34
- Inspection - Transport .....	34
- Conditions à vérifier pour une mise en marche correcte .....	34
- Entretien général .....	34
- Dangers .....	34
- Normes de référence .....	34
- Instructions pour une installation correcte .....	35
- Caractéristiques constructives et dimensionnelles .....	35
- Schéma de connexion motoventilateurs .....	37
- Instructions pour accéder à l'appareil .....	38
- Schéma de connexion et puissances des résistances électriques .....	38
- Garantie .....	51

### Содержание

- Меры предосторожности .....	42
- Осмотр - Транспортировка .....	42
- Условия для выполнения корректного ввода в эксплуатацию .....	42
- Общее техобслуживание .....	42
- Опасность/ Риски .....	42
- Ссылка на стандарты .....	42
- Меры предосторожности для корректной установки .....	43
- Конструктивные и пространственные характеристики .....	43
- Схема подключения мотоventilаторов .....	45
- Рекомендации по корректному доступу к аппарату .....	46
- Схема подключений и мощностей электрических сопротивлений .....	46
- Гарантии .....	51

## Avvertenze

1. Conservare questo manuale tecnico per tutto il periodo di vita del modello.
2. Leggere con attenzione il manuale prima dell'installazione e prima di qualsiasi operazione sul modello.
3. Impiegare il modello esclusivamente per lo scopo per cui è stato progettato: l'uso improprio esonera il costruttore da qualsiasi responsabilità.

## Ispezione - Trasporto

1. Al ricevimento del modello controllare immediatamente il suo stato; contestare subito alla compagnia di trasporto qualsiasi eventuale danno.
2. Durante il trasporto evitare di esercitare pressioni improprie sull'imballaggio, che va mantenuto comunque sempre nella posizione indicata sullo stesso.
3. Disimballare il modello il più vicino possibile al luogo di installazione. Una volta disimballato, evitare urti ai componenti.
4. Durante l'installazione e la movimentazione del modello utilizzare appositi guanti protettivi per evitare di ferirsi con le parti taglienti (es. alette) del modello.

## Condizioni da verificare per una corretta messa in opera

1. Verificare la tenuta delle strutture di sostegno rispetto al peso dell'apparecchio.
2. Verificare che il modello venga installato orizzontalmente.
3. Assicurare un volume libero adeguato (circa il 30% del volume interno della cella) per una corretta circolazione dell'aria in aspirazione e scarico.

**Particolari condizioni di installazione o funzionamento quali celle basse, travature a soffitto, stoccaggi eccessivi, impedimenti al getto e/o all'aspirazione dell'aria, formazione impropria di brina dovuta ad eccessiva immissione di umidità nella cella, possono influenzare negativamente le prestazioni dichiarate e creare difettosità nei modelli.**

**I modelli standard possono non essere adatti ad operare in tunnel o celle di abbattimento/surgelamento rapido.**

4. I modelli sono equipaggiati con motoventilatori assiali, quindi non adatti ad essere canalizzati o comunque a sopportare prevalenze statiche aggiuntive.
5. Verificare che le condizioni di funzionamento (temperature e pressioni) siano conformi a quelle di progetto.
6. Prestare particolare cura in fase di collegamento affinché non si deformino i capillari e non si modifichi la posizione del distributore.
7. In caso di più modelli installati a breve distanza l'uno dall'altro, evitare sbrinamenti alternati.
8. Installare sugli scarichi condensa gli opportuni sifoni e verificarne l'efficacia in tutte le temperature di utilizzo.
9. Evitare l'installazione degli aeroevaporatori vicino alle porte delle celle.
10. Collocare la sonda di temperatura per il fine sbrinamento nelle zone più fredde degli scambiatori, ovvero quelle zone che tendono a ghiacciarsi maggiormente (al termine del ciclo non deve rimanere ghiaccio sui modelli). La posizione di questo dispositivo non può essere definita a priori, in quanto varia in relazione al tipo di cella e al tipo di impianto.
11. Verificare che la linea elettrica di alimentazione sia adeguata alle caratteristiche elettriche dell'apparecchio.
12. Assicurarsi che tutti i collegamenti elettrici siano in accordo con le norme vigenti.
13. Le unità sono predisposte per il collegamento elettrico a terra. L'installatore e/o il conduttore dell'unità sono tenuti a garantire la presenza di un efficiente collegamento alla terra di protezione contro i contatti elettrici indiretti.

A richiesta i modelli possono essere forniti con scambiatori, sbrinatori e motoventilatori diversi dallo standard.

Le resistenze elettriche impiegate per l'eventuale sbrinamento sono alloggiare in scatola di derivazione in materiale termoplastico (protezione contro il contatto elettrico diretto di classe II) aventi grado di protezione IP 54.

14. Ad installazione completata rimuovere la pellicola protettiva che ricopre il modello.
15. L'accessibilità al modello, per qualsiasi tipo di intervento, deve essere riservata al personale qualificato alla conduzione dell'impianto, secondo le norme vigenti.

## Manutenzione generale

1. Verificare periodicamente i fissaggi, le connessioni elettriche e i collegamenti all'impianto frigorifero.
2. Provvedere alla pulizia periodica dell'apparecchio, per evitare accumuli di sostanze nocive. Si consiglia l'utilizzo di normale acqua saponata, evitando solventi, agenti aggressivi, abrasivi o a base di ammoniaca.
3. In caso di sostituzioni di resistenze elettriche prestare particolare attenzione nelle fasi di installazione per evitare danni alle vulcanizzazioni; ripristinare correttamente i collegamenti e i sistemi di fissaggio esistenti per evitare movimenti delle stesse durante il funzionamento.

**Tali operazioni dovranno essere effettuate da personale esperto e qualificato.**

## Pericoli

1.  Pericolo di elettrocuzione. Il modello è provvisto di elettroventilatori e resistenze elettriche di sbrinamento. La tensione di alimentazione è di 400V AC. Utilizzare sistemi di sicurezza elettrica previsti dalla normativa vigente.
2.  Pericolo di ustione. Le resistenze elettriche di sbrinamento possono raggiungere temperature superficiali di 350°C.
3.  Pericolo di taglio. Lo scambiatore di calore è costituito da alette con bordi taglienti e la carrozzeria da parti in lamiera.
4.  Pericolo parti in movimento. Il modello è provvisto di elettroventilatori dotati di griglia di protezione esterna.
5.  Pericolo di schiacciamento. Il modello può pesare oltre 100 kg.

## Norme di riferimento

- DIRETTIVA MACCHINE 2006/42/EC
- DIRETTIVA BASSA TENSIONE 2014/35/UE
- DIRETTIVA COMP. ELETTROMAGNETICA 2014/30/UE
- DIRETTIVA PED 2014/68/UE
- DIRETTIVA ERP 2009/125/EC

### Attenzione

Prima di effettuare qualsiasi intervento di manutenzione, accertarsi che l'alimentazione elettrica sia scollegata dalla fonte principale: le parti elettriche potrebbero essere collegate ad un controllo automatico.

## Avvertenze per una corretta installazione

### Distanza minima laterale dalla parete lato resistenze e distanza minima dalla parete lato aspirazione

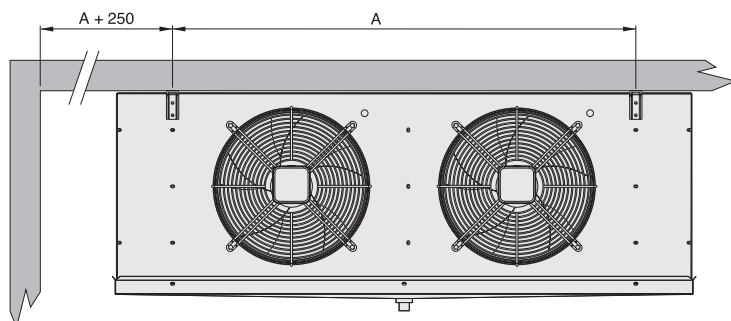

In fase di installazione rispettare la quota minima A+250 mm per poter togliere/inserire le resistenze.

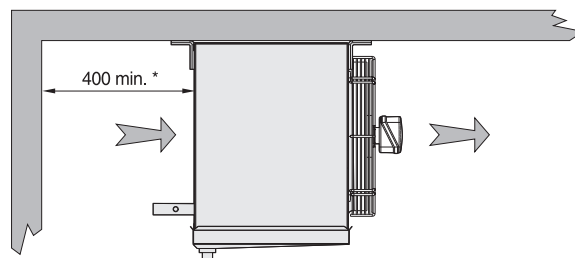

In fase di installazione rispettare la quota minima di 400 mm per un buon funzionamento del motore.

## Caratteristiche costruttive e dimensionali

### Modello con ventola ø 250 mm

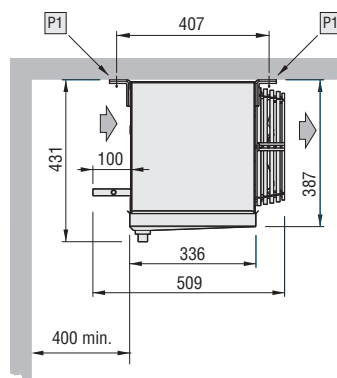
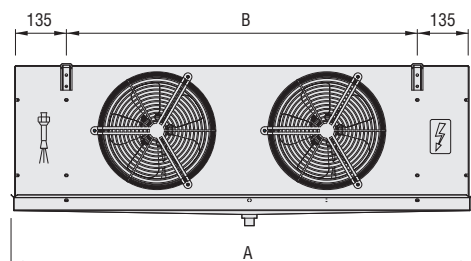

Particolare di fissaggio

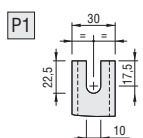

#### Particolari di posizionamento resistenze

##### 3RR

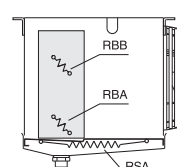

##### 4RR

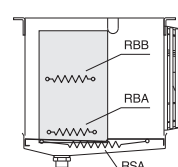

##### 4RR (251ExR)

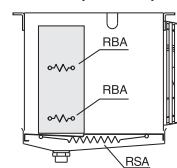

**RBA** - Resistenza elettrica di alta potenza nella batteria.

**RBB** - Resistenza elettrica di bassa potenza nella batteria.

**RSA** - Resistenza elettrica sullo sgocciolatoio interno.

Modello	GCE	251 E4R	251 E4	252 G4	252 E4	253 G4	253 E4	254 G4	254 E4
		251 E6R	251 E6	252 G6	252 E6	253 G6	253 E6	254 G6	254 E6
		251 E8R	251 E8	252 G8	252 E8	253 G8	253 E8	254 G8	254 E8
Motoventilatori	n° x Ø mm	1x250	1x250	2x250	2x250	3x250	3x250	4x250	4x250
Dimensioni	A	674	774	1224	1224	1674	1674	2124	2124
	B	380	480	930	930	1380	1380	1830	1830
Attacchi scamb.	In tube (mm)	12	12	12	12	12	12	12	16
	Out tube (mm)	12	12	22	22	22	22	22 (G4: 28)	28
Attacco scarico	Ø (GAS)	1"	1"	1"	1"	1"	1"	1"	1"
Peso netto	kg	13	14,5	21,5	24	30	33	38	41,5

Impiegare valvola termostatica con equalizzatore di pressione esterno

## Caratteristiche costruttive e dimensionali

### Modello con ventola $\varnothing$ 315 mm

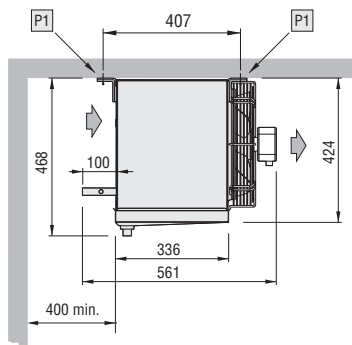
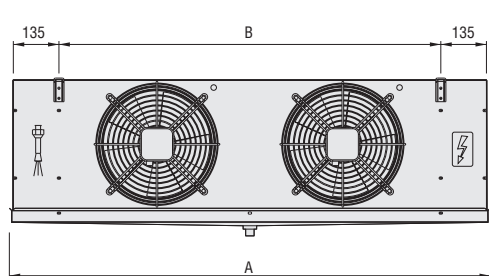

#### Particolari di posizionamento resistenze

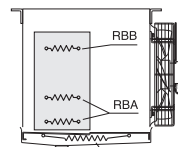

**RBA** - Resistenza elettrica di alta potenza nella batteria.  
**RBB** - Resistenza elettrica di bassa potenza nella batteria.  
**RSA** - Resistenza elettrica sullo sgocciolatoio interno.

P1

#### Particolare di fissaggio

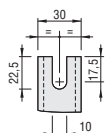

Modello	GCE	311F4 311F6 311F8	312F4 312F6 312F8	313F4 313F6 313F8	314F4 314F6 314F8
Motoventilatori	n° x $\varnothing$ mm	1x315	2x315	3x315	4x315
Dimensioni	A	874	1424	1974	2524
	B	580	1130	1680	2230
Attacchi scambiatore	In tube (mm)	12	12	16	16 (F4: 22)
	Out tube (mm)	22	28	28	28 (F8: 35)
Attacco scarico	$\varnothing$ (GAS)	1"	1"	1"	1"
Peso netto	kg	20	34	47,5	61

Impiegare valvola termostatica con equalizzatore di pressione esterno

### Modello con ventola $\varnothing$ 350 mm

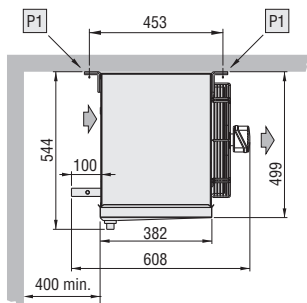
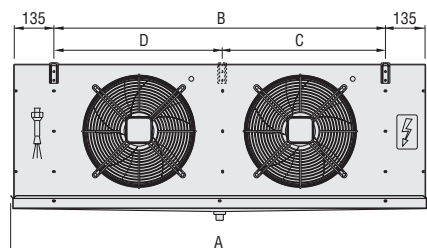

P1

#### Particolare di fissaggio

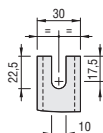

35°E4 ED 35°F4 ED  
35°E6 ED 35°F6 ED  
35°E8 ED 35°F8 ED

35°E4 EDP 35°F4 EDP  
35°E6 EDP 35°F6 EDP  
35°E8 EDP 35°F8 EDP

35°A4 ED 35°A6 ED 35°A8 ED

35°A4 EDP 35°A6 EDP 35°A8 EDP

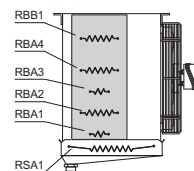
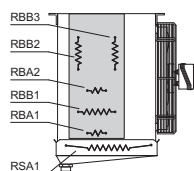
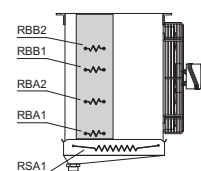
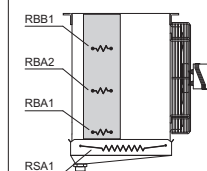

#### Particolari di posizionamento resistenze

**RBA** - Resistenza elettrica di alta potenza nella batteria.  
**RBB** - Resistenza elettrica di bassa potenza nella batteria.  
**RSA** - Resistenza elettrica sullo sgocciolatoio interno.

Modello	GCE	351 E4 351 E6 351 E8	351A4 351A6 351A8	352 E4 352 E6 352 E8	352 A4 352 A6 352 A8	353 F4 353 F6 353 F8	353A4 353A6 353A8	354 F4 354 F6 354 F8	354 A4 354 A6 354 A8	355 A4 355 A6 355 A8
Motoventilatori	n° x $\varnothing$	1x350	1x350	2x350	2x350	3x350	3x350	4x350	4x350	5x350
Dimensioni	A mm	875	875	1425	1425	1975	1975	2525	2525	3075
	B mm	580	580	1130	1130	1680	1680	2230	2230	2780
	C mm	-	-	-	-	-	-	1115	1115	1665
	D mm	-	-	-	-	-	-	1115	1115	1115
Attacchi scambiatore	In tube (mm)	12	12	16	16	16 (F4: 22)	22	22	28	28
	Out tube (mm)	22	22	28	28	28 (F8: 35)	35	35 (F8: 42)	42	42
Attacco scarico	$\varnothing$ (GAS)	1	1	1	1	1	1	1	1	1
Peso netto	kg	22	26,5	41	48	58	63	77	83,5	103

Impiegare valvola termostatica con equalizzatore di pressione esterno

## Schema di collegamento dei motoventilatori

### Attenzione

I motori sono dotati di termocontatti di protezione interni a riarmo automatico.

Prima di utilizzare sistemi di regolazione del numero di giri dei motori verificare la compatibilità con i motori stessi, sistemi non compatibili possono generare rumorosità e danneggiamenti; il costruttore non si assume responsabilità alcuna sulle prestazioni dei modelli equipaggiati con sistemi di regolazione.

Modello GCE	251 E4R 251 E6R 251 E8R	251 E4 251 E6 251 E8	252G4 252G6 252G8	252 E4 252 E6 252 E8	253G4 253G6 253G8	253 E4 253 E6 253 E8	254G4 254G6 254G8	254 E4 254 E6 254 E8	311F4 311F6 311F8	312F4 312F6 312F8	313F4 313F6 313F8	314F4 314F6 314F8					
Motori	1 x 250		2 x 250		3 x 250		4 x 250		1 x 315		2 x 315		3 x 315		4 x 315		
Frequenza	Hz	50	60	50	60	50	60	50	60	50	60	50	60	50	60	50	60
Assorbimento	A	0,68	-	1,36	-	2,04	-	2,72	-	0,52	0,66	1,04	1,32	1,56	1,98	2,08	2,64
	W	95	-	190	-	285	-	380	-	110	148	220	296	330	444	440	592
RPM		1300	1550	1300	1550	1300	1550	1300	1550	1350	1490	1350	1490	1350	1490	1350	1490

Modello GCE	351 E4 351 E6 351 E8	351A4 351A6 351A8	352 E4 352 E6 352 E8	352 A4 352 A6 352 A8	353 F4 353 F6 353 F8	353A4 353A6 353A8	354 F4 354 F6 354 F8	354 A4 354 A6 354 A8	355 A4 355 A6 355 A8		
Motori	1 x 350		2 x 350		3 x 350		4 x 350		5 x 350		
Frequenza	Hz	50	60	50	60	50	60	50	60	50	60
Assorbimento	A	0,96	1,08	1,92	2,16	2,88	3,24	3,84	4,32	4,80	5,40
	W	185	250	370	500	555	750	740	1000	925	1250
RPM		1420	1660	1420	1660	1420	1660	1420	1660	1420	1660

### Schema di collegamento motoventilatori ø 250 mm

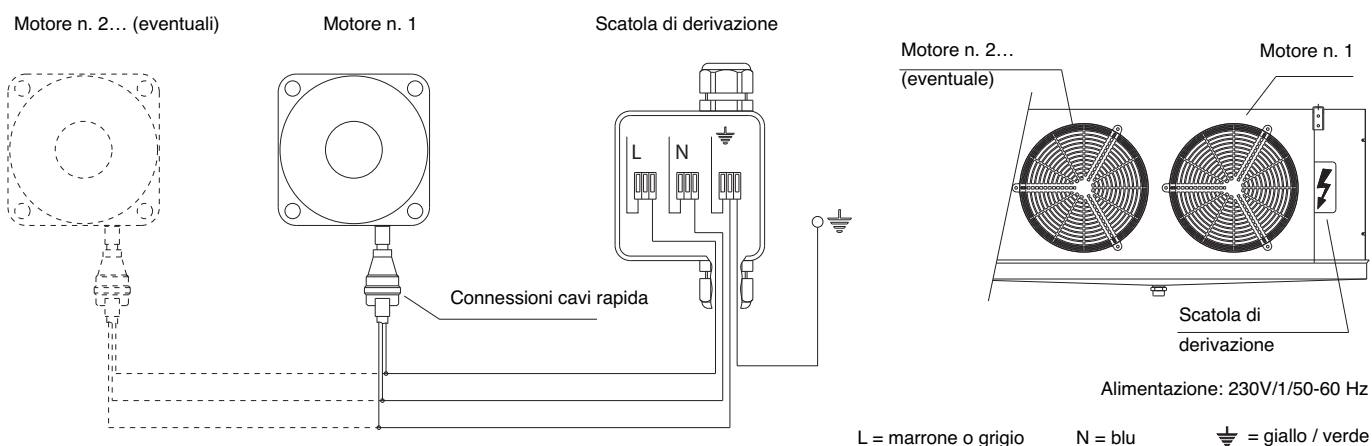

### Schema di collegamento motoventilatori ø 315 - 350 mm

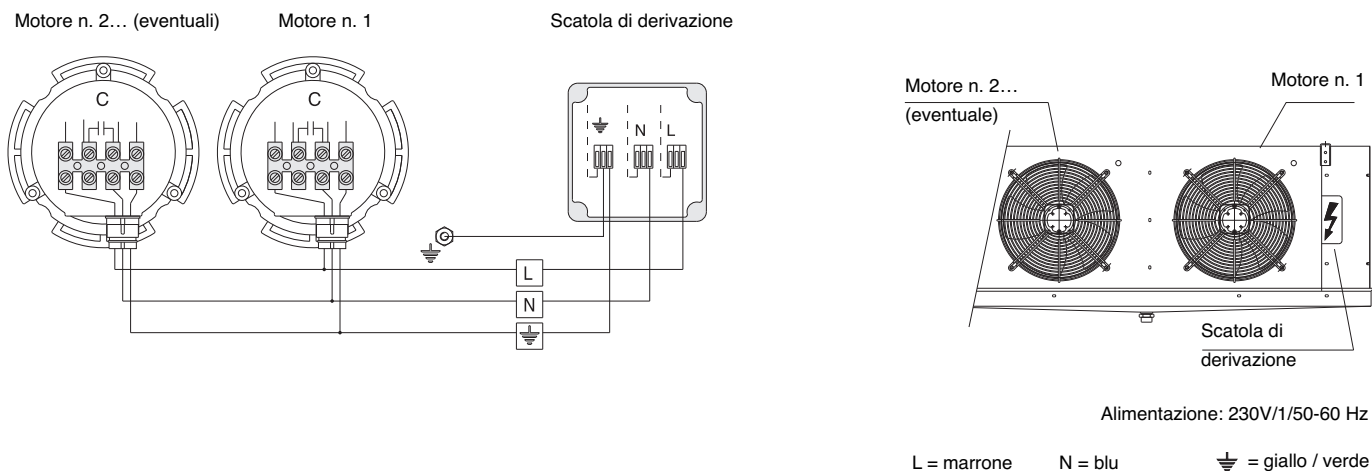

## Suggerimenti per un corretto accesso all'apparecchio

### Accesso

1. Smontare il tubo di scarico condensa.
2. Accertarsi che la vaschetta sia libera da eventuali residui di ghiaccio prima di rimuoverla svitando le viti "A".
3. Allentare le viti autofilettanti "B", senza toglierle completamente, quindi sfilare il coperchio laterale.

### Riposizionamento

1. Ricollocare il coperchio laterale e fissarlo mediante le viti "B".
2. Rimettere la vaschetta in posizione, avendo cura che i coperchi laterali siano interni alla stessa, quindi fissarla con le viti "A".
3. Rimontare il tubo di scarico condensa.

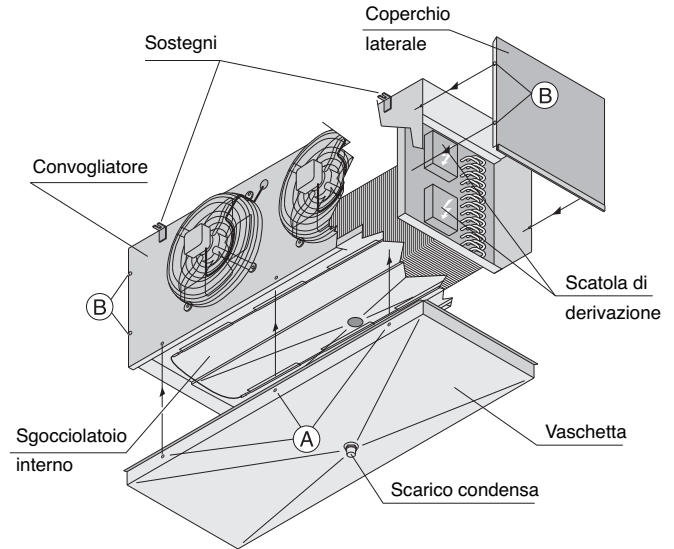

## Schemi di collegamento e potenze delle resistenze elettriche

### Attenzione

È d'obbligo l'applicazione di opportuni sistemi di protezione termica sulle linee di alimentazione. Provvedere periodicamente alla verifica delle funzionalità di tutte le resistenze per evitare accumuli dannosi di ghiaccio sui modelli. Il costruttore non risponde in alcun modo di difettosità create da malfunzionamenti non rilevati.

### Modello con ventola ø 250 mm

COLLEGAMENTO 400V/3/50 Hz **PREDISPOSTO**

GCE 251ExR

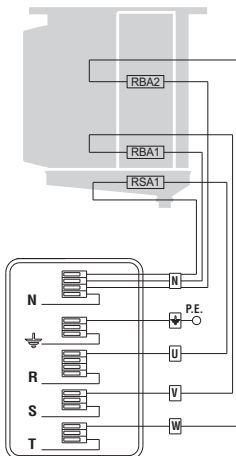
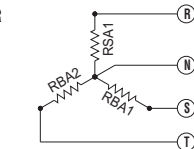

GCE 252Gx  
253Gx  
254Gx

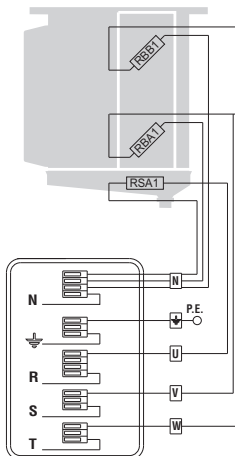
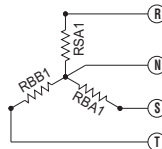

GCE 251Ex  
252Ex  
253Ex  
254Ex

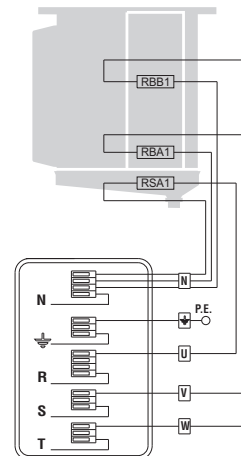
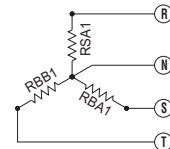

### RBA (1-2)

Resistenze di alta potenza nella batteria.

### RBB1

Resistenza di bassa potenza nella batteria.

### RSA1

Resistenza di alta potenza sullo sgocciolatoio interno.

Modello GCE "ED" ø 250	251E4R	251E4	252G4	252E4	253G4	253E4	254G4	254E4
	251E6R	251E6	252G6	252E6	253G6	253E6	254G6	254E6
	251E8R	251E8	252G8	252E8	253G8	253E8	254G8	254E8
Ranghi	4 RR	4 RR	3 RR	4 RR	3 RR	4 RR	3 RR	4 RR
Potenza totale (W)	750	1125	2250	2250	3325	3325	4375	4375



## Schemi di collegamento e potenze delle resistenze elettriche

### Attenzione

È d'obbligo l'applicazione di opportuni sistemi di protezione termica sulle linee di alimentazione.  
Provvedere periodicamente alla verifica delle funzionalità di tutte le resistenze per evitare accumuli dannosi di ghiaccio sui modelli.  
Il costruttore non risponde in alcun modo di difettosità create da malfunzionamenti non rilevati.

### Modello con ventola ø 250 mm

#### COLLEGAMENTO 230V/1/50 Hz DA PREDISPORRE

GCE 251ExR

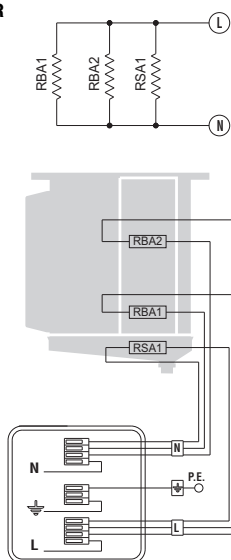

GCE 252Gx  
253Gx  
254Gx

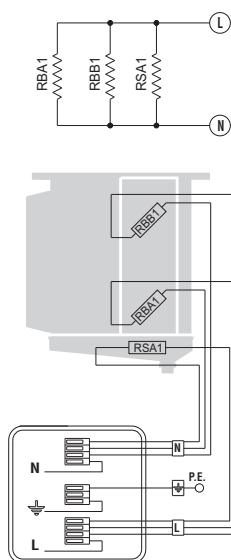

GCE 251Ex  
252Ex  
253Ex  
254Ex

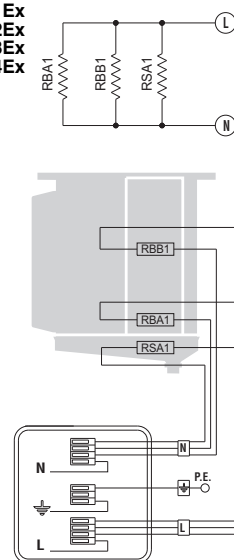

#### RBA (1-2)

Resistenze di alta potenza nella batteria.

#### RBB1

Resistenza di bassa potenza nella batteria.

#### RSA1

Resistenza di alta potenza sullo sgocciolatoio interno.

Modello GCE "ED" ø 250	251E4R	251E4	252G4	252E4	253G4	253E4	254G4	254E4
	251E6R	251E6	252G6	252E6	253G6	253E6	254G6	254E6
	251E8R	251E8	252G8	252E8	253G8	253E8	254G8	254E8
Ranghi	4 RR	4 RR	3 RR	4 RR	3 RR	4 RR	3 RR	4 RR
Potenza totale (W)	750	1125	2250	2250	3325	3325	4375	4375

### Modello con ventola ø 315 mm

#### COLLEGAMENTO 400V/3/50 Hz (predisposto)

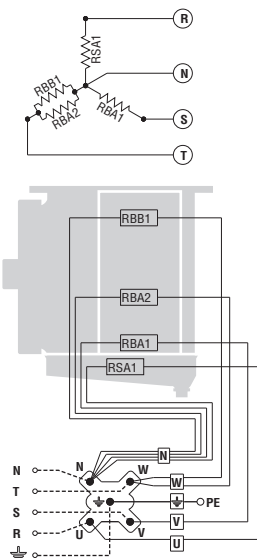

#### COLLEGAMENTO 230V/1/50 Hz (da predisporre)

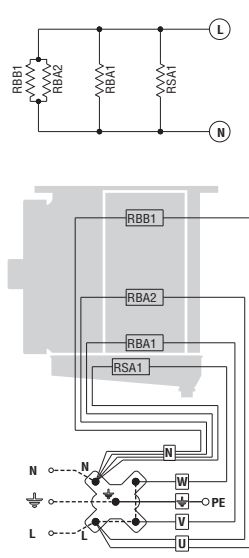

**RBA (1-2)** Resistenze di alta potenza nella batteria.  
**RBB1** Resistenza di bassa potenza nella batteria.  
**RSA1** Resistenza di alta potenza sullo sgocciolatoio interno.

Modello GCE "ED" ø 315	311F4	312F4	313F4	314F4
	311F6	312F6	313F6	314F6
	311F8	312F8	313F8	314F8
Ranghi	5 RR	5 RR	5 RR	5 RR
Potenza totale (W)	1750	3150	4900	6300

# Schemi di collegamento e potenze delle resistenze elettriche

**Attenzione**  
 È d'obbligo l'applicazione di opportuni sistemi di protezione termica sulle linee di alimentazione.  
 Provvedere periodicamente alla verifica delle funzionalità di tutte le resistenze per evitare accumuli dannosi di ghiaccio sui modelli.  
 Il costruttore non risponde in alcun modo di difettosità create da malfunzionamenti non rilevati.

## Modello con ventola ø 350 mm 4-5 RR standard

COLLEGAMENTO 400V/3/50 Hz  
(predisposto)

COLLEGAMENTO 230V/1/50 Hz  
(da predisporre)

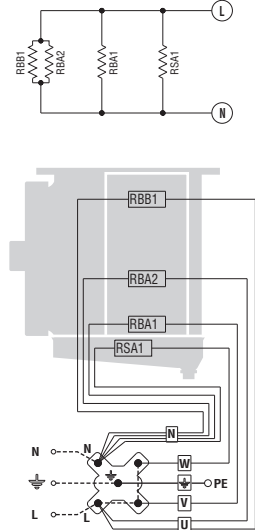
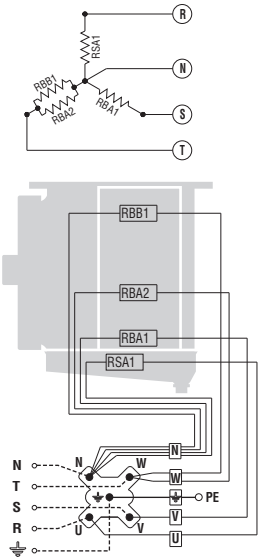

**RBA (1-2)** Resistenze di alta potenza nella batteria.  
**RBB1** Resistenza di bassa potenza nella batteria.  
**RSA1** Resistenza di alta potenza sullo sgocciolatoio interno.

Modello GCE "ED" ø 350	351 E4	352 E4	353 F4	354 F4
	351 E6	352 E6	353 F6	354 F6
	351 E8	352 E8	353 F8	354 F8
Ranghi	4 RR	4 RR	5 RR	5 RR
Potenza totale (W)	1750	3150	4900	6300

## Modello con ventola ø 350 mm 4-5 RR potenziato

COLLEGAMENTO 400V/3/50 Hz  
(predisposto)

COLLEGAMENTO 230V/1/50 Hz  
(da predisporre)

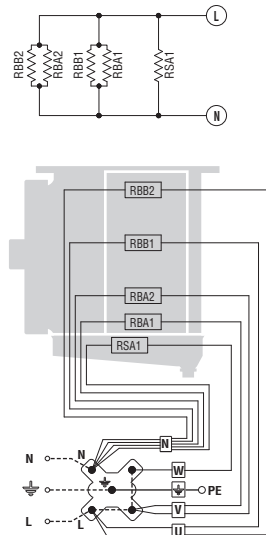
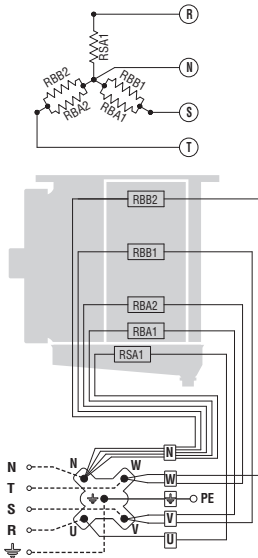

**RBA (1-2)** Resistenze di alta potenza nella batteria.  
**RBB (1-2)** Resistenza di bassa potenza nella batteria.  
**RSA1** Resistenza di alta potenza sullo sgocciolatoio interno.

Modello GCE "ED" ø 350	351 E4	352 E4	353 F4	354 F4
	351 E6	352 E6	353 F6	354 F6
	351 E8	352 E8	353 F8	354 F8
Ranghi	4 RR	4 RR	5 RR	5 RR
Potenza totale (W)	2000	3600	5600	7200

## Schemi di collegamento e potenze delle resistenze elettriche

### Attenzione

È d'obbligo l'applicazione di opportuni sistemi di protezione termica sulle linee di alimentazione. Provvedere periodicamente alla verifica delle funzionalità di tutte le resistenze per evitare accumuli dannosi di ghiaccio sui modelli. Il costruttore non risponde in alcun modo di difettosità create da malfunzionamenti non rilevati.

### Modello con ventola ø 350 mm

### 6RR standard

COLLEGAMENTO 400V/3/50 Hz  
(predisposto)

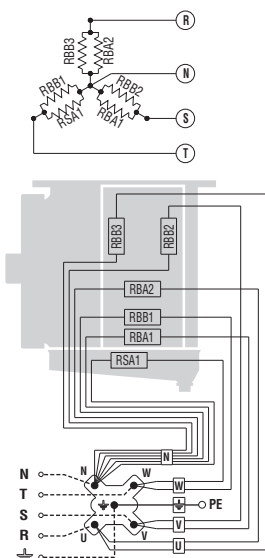

COLLEGAMENTO 230V/3/50 Hz  
(da predisporre)

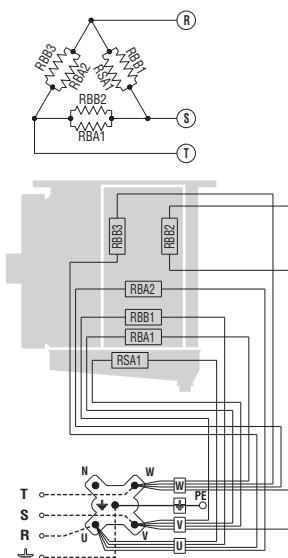

COLLEGAMENTO 230V/1/50 Hz  
(da predisporre)

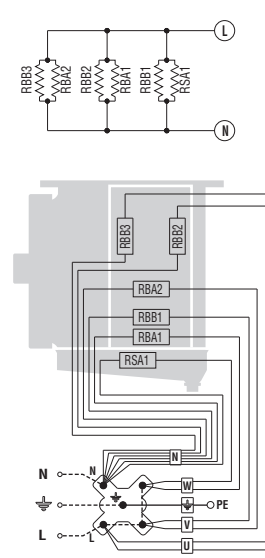

- RBA (1-2)** Resistenze di alta potenza nella batteria.
- RBB (1-2-3)** Resistenza di bassa potenza nella batteria.
- RSA1** Resistenza di alta potenza sullo sgocciolatoio interno.

Modello GCE "ED" ø 350	351 A4 351 A6 351 A8	352 A4 352 A6 352 A8	353 A4 353 A6 353 A8	354 A4 354 A6 354 A8	355 A4 355 A6 355 A8
Ranghi	6 RR	6 RR	6 RR	6 RR	6 RR
Potenza totale (W)	2250	4050	6300	8100	9900

### Modello con ventola ø 350 mm

### 6RR potenziato

COLLEGAMENTO 400V/3/50 Hz  
(predisposto)

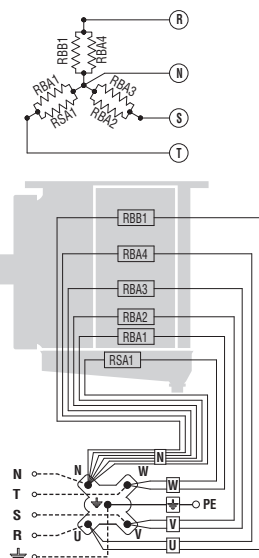

COLLEGAMENTO 230V/1/50 Hz  
(da predisporre)

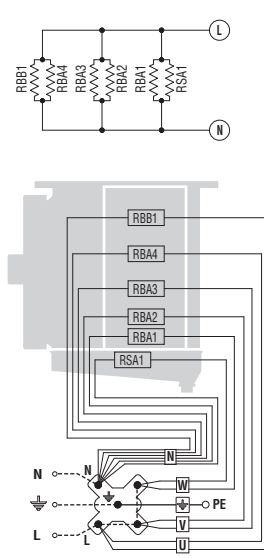

- RBA (1-2-3-4)** Resistenze di alta potenza nella batteria.
- RBB1** Resistenza di bassa potenza nella batteria.
- RSA1** Resistenza di alta potenza sullo sgocciolatoio interno.

Modello GCE "ED" ø 350	351 A4 351 A6 351 A8	352 A4 352 A6 352 A8	353 A4 353 A6 353 A8	354 A4 354 A6 354 A8	355 A4 355 A6 355 A8
Ranghi	6 RR	6 RR	6 RR	6 RR	6 RR
Potenza totale (W)	2750	4950	7700	9900	12100

## Hinweise

1. Diese Betriebsanleitung während der ganzen Lebensdauer des Geräts aufbewahren.
2. Vor Inbetriebnahme des Geräts und vor jedem Eingriff aufmerksam die Betriebsanleitung durchlesen.
3. Das Gerät nur für den Zweck einsetzen, wofür es entworfen worden ist; unsachgemäße Anwendung befreit den Hersteller von jeder Verantwortung.

## Kontrolle - Transport

1. Bei Erhalt des Geräts sofort den Zustand kontrollieren; jeglichen eventuellen Schaden sofort dem Spediteur beanstanden.
2. Während des Transports unnötigen Druck auf die Verpackung vermeiden.
3. Während der Montage und des Positionierens des Geräts geeignete Schutzhandschuhe benutzen, um eine Verletzungsgefahr durch scharfe Stellen am Gerät zu vermeiden.
4. Während der Montage und des Positionierens des Geräts geeignete Schutzhandschuhe benutzen, um eine Verletzungsgefahr durch scharfe Stellen (z.B. Lamellen) zu vermeiden.

## Hinweise für eine korrekte Inbetriebnahme

1. Die Tragfähigkeit der Strukturen bezüglich des Gerätegewichts überprüfen.
2. Das Modell muß horizontal eingebaut werden.
3. Für eine einwandfreie Luftzirkulation muß genügend Freiraum vorhanden sein (ungefähr 30% des Innenvolumens der Zelle).

**Besondere Einbau- oder Betriebsbedingungen, wie niedrige Kühlzellen, Deckenträger, übermäßige Lagerung, Behinderungen des Luftstroms und/oder der Luftansaugung, übermäßige Reifbildung durch zu hohe Feuchtigkeit in der Kühlzelle können die angegebenen Leistungen negativ beeinflussen und Schäden an den Geräten hervorrufen.**

Die Standardmodelle können für die Anwendung in Schnellabkühlungs- oder Schockräumen nicht geeignet sein.

4. Die Modelle sind mit Axialmotorventilatoren ausgestattet und daher nicht kanalisierbar oder jedenfalls keine weiteren Druckverluste verkraften.
5. Die Betriebsbedingungen (Temperaturen und Drucke) müssen dem Projekt entsprechen.
6. Das Anschließen muß sorgfältig erfolgen, um das Verformen eventueller Kapillarrohre und das Verlagern des Verteilers zu verhindern.
7. Bei nah aneinander installierten Geräten abwechselnde Abtaungen vermeiden.
8. An den Tauwasserabflüssen die passenden Siphone installieren und die Wirksamkeit bei allen Anwendungstemperaturen überprüfen.
9. Die Installation der Luftverdampfer in der Nähe der Zellentüren vermeiden.
10. Die Temperaturfühler für das Ende der Abtaung in den kältesten Zonen der Wärmeaustauscher anbringen, beziehungsweise in den Zonen, wo die Tendenz zur Eisbildung am größten ist (am Ende der Abtaung darf kein Eis an den Modellen bleiben). Die Lage dieser kann nicht vorherbestimmt werden, da sie sich je nach Typ der Zelle und der Anlage verändert.
11. Die Stromzuleitung muß den elektrischen Daten des Geräts angepaßt sein.
12. Alle Anschlüsse müssen den gültigen elektrischen Normen entsprechen.
13. Die Einheiten sind für den elektrischen Erdungsanschluss vorgesehen. Der Installationsfachmann bzw. Betreiber der Einheit muss einen funktionstüchtigen Anschluss an den

Erdungsschutzleiter gegen indirekte Stromkontakte gewährleisten. Die elektrischen Widerstände für das Abtausystem sind in einer Verteilerdose aus thermoplastischem Material untergebracht mit Schutzgrad IP 54. Auf Bestellung können die Modelle mit nicht standardmäßigen Wärmeaustauschern, Abtausystemen und Lüfteraggregaten geliefert werden.

14. Nach beendeter Installation den am Gerät befindlichen Schutzfilm entfernen.
15. Der Zugang zum Gerät für jeden Eingriff muß dem für die Anlage qualifizierten Personal gemäß den gültigen Normen vorbehalten sein.

## Allgemeine Wartung

1. Regelmäßige Überprüfung der Befestigungen der elektrischen Anschlüsse. Kältemittelanschlüsse auf Dichtheit prüfen.
2. Regelmäßige Reinigung des Geräts mit normalem Seifenwasser, um das Anhäufen von schädlichen Substanzen zu verhindern. Keine Lösungsmittel und aggressive oder ammoniakhaltige Reibepulver verwenden.
3. Beim eventuellen Auswechseln von elektrischen Heizstäben besonders achtgeben, um während der Installation Schäden an der Vulkanisierung zu vermeiden; die Anschlüsse und die bestehenden Befestigungssysteme wieder korrekt herstellen, um zu vermeiden, daß sie sich während des Betriebs bewegen.

**Die Wartung darf nur von qualifiziertem Personal vorgenommen werden.**

## Gefahren

1.  Stromschlaggefahr. Das Gerät ist mit Motorventilatoren und elektrischen Abtauheizungen versehen. Die Stromspannung ist 400 V AC. Elektrische Sicherheitssysteme gemäß den geltenden Normen anwenden.
2.  Verbrennungsgefahr. Die elektrischen Abtauheizungen können Oberflächentemperaturen von 350° C erreichen.
3.  Schnittgefahr. Der Wärmeaustauscher besteht aus Lamellen mit scharfen Kanten und das Gehäuse besteht aus Blechteilen.
4.  Gefahr durch sich bewegende Teile. Das Gerät ist mit Motorventilatoren mit äußerem Schutzgitter versehen.
5.  Quetschgefahr. Das Gerät kann über 100 kg wiegen.

## Bezugsnormen

- MASCHINEN - RICHTLINIE 2006/42/EC
- NIEDERSpannung - RICHTLINIE 2014/35/UE
- RICHTLINIE ELEKTROMAGNETISCHE KOMP. 2014/30/UE
- PED RICHTLINIE 2014/68/UE
- ERP RICHTLINIE 2009/125/EC

### Achtung

Versichern Sie sich vor jeder Wartung, daß die Stromzuführung vom Hauptnetz getrennt ist; die elektrischen Teile könnten automatisch anlaufen.

## Hinweise für eine korrekte Aufstellung

### Mindestabstand von der Wand, Heizstabseite - Mindestabstand von der Wand, Ansaugseite

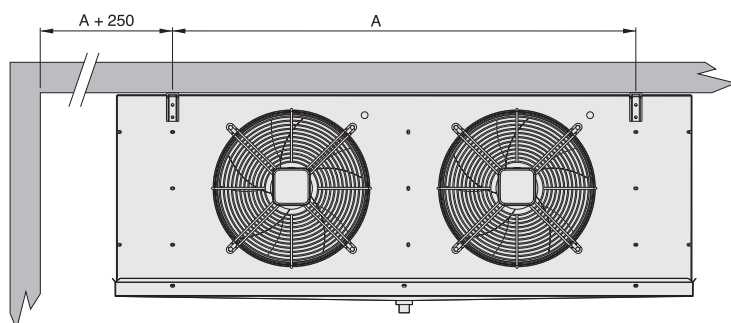

Zum seitlichen Ein- und Ausbau der Heizstäbe muß bei der Geräteinstallation das Mindestmaß A+250 mm eingehalten werden.

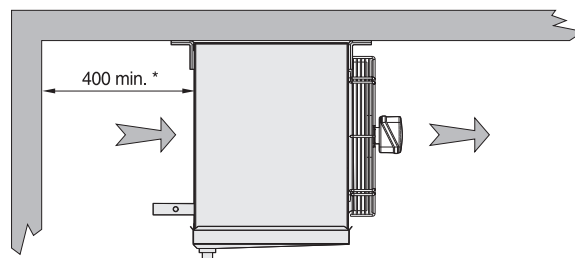

Für einen optimalen Betrieb des Motors den Mindestabstand 400 mm bei der Montage einhalten.

Deutsch

## Konstruktionseigenschaften und Abmessungen

### Modell mit Flügel Durchmesser 250 mm

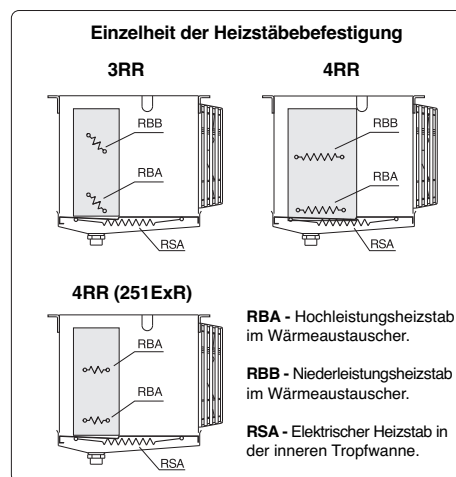
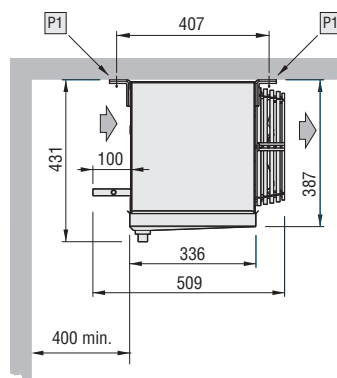
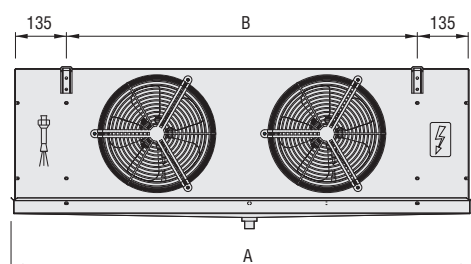

Modell	GCE	251 E4R	251 E4	252 G4	252 E4	253 G4	253 E4	254 G4	254 E4
		251 E6R	251 E6	252 G6	252 E6	253 G6	253 E6	254 G6	254 E6
		251 E8R	251 E8	252 G8	252 E8	253 G8	253 E8	254 G8	254 E8
Motorventilatoren	n° x Ø mm	1x250	1x250	2x250	2x250	3x250	3x250	4x250	4x250
Abmessungen	A	674	774	1224	1224	1674	1674	2124	2124
	B	380	480	930	930	1380	1380	1830	1830
Innere Batterie=anschlüsse	Eintritt (mm)	12	12	12	12	12	12	12	16
	Austritt (mm)	12	12	22	22	22	22	22 (G4: 28)	28
Tauwasserabfluß	Ø (GAS)	1"	1"	1"	1"	1"	1"	1"	1"
Nettogewicht	kg	13	14,5	21,5	24	30	33	38	41,5

Thermostatisches Ventil mit Aussendruck-Kompensator anwenden

# Konstruktionseigenschaften und Abmessungen

## Modell mit Flügeldurchmesser 315 mm

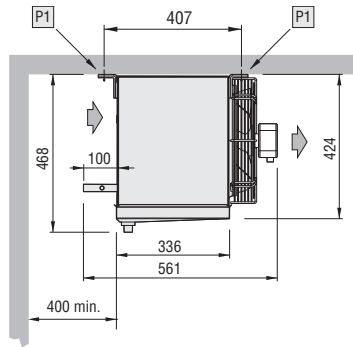
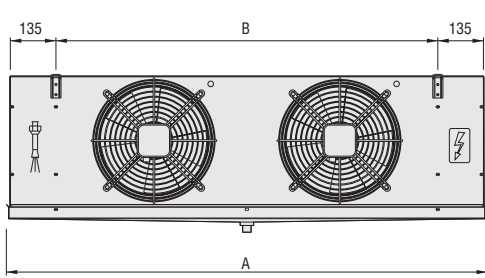

### Einzelheit der Heizstäbebefestigung

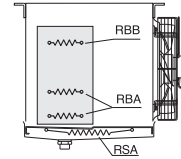

RBA - Hochleistungsheizstab im Wärmeaustauscher.  
RBB - Niederleistungsheizstab im Wärmeaustauscher.  
RSA - Elektrischer Heizstab in der inneren Tropfwanne.

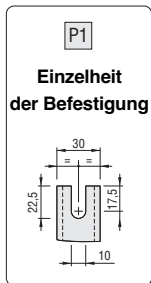

Modell	GCE	311F4		312F4		313F4		314F4	
		311F6	311F8	312F6	312F8	313F6	313F8	314F6	314F8
Motorventilatoren	n° x Ø mm	1x315		2x315		3x315		4x315	
Abmessungen	A	874		1424		1974		2524	
	B	580		1130		1680		2230	
Innere Batterie=anschlüsse	Eintritt (mm)	12		12		16		16 (F4: 22)	
	Austritt (mm)	22		28		28		28 (F8: 35)	
Tauwasserabfluß	Ø (GAS)	1"		1"		1"		1"	
Nettogewicht	kg	20		34		47,5		61	

Thermostatisches Ventil mit Aussendruck-Kompensator anwenden

## Modell mit Flügeldurchmesser 350 mm

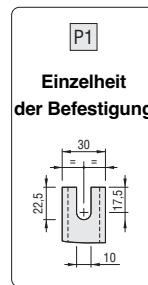
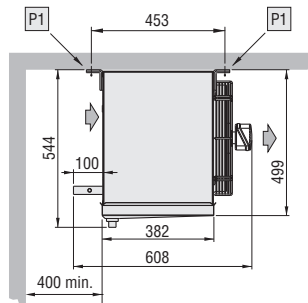
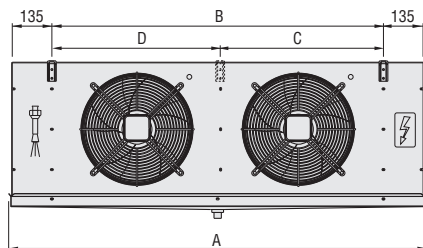

### Einzelheit der Heizstäbebefestigung

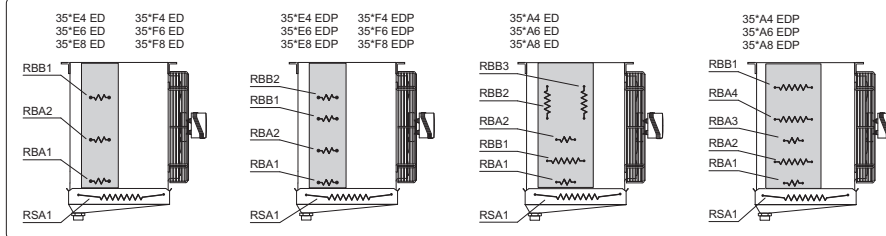

RBA - Hochleistungsheizstab im Wärmeaustauscher.  
RBB - Niederleistungsheizstab im Wärmeaustauscher.  
RSA - Elektrischer Heizstab in der inneren Tropfwanne.

Modello	GCE	351 E4	351A4	352 E4	352 A4	353 F4	353A4	354 F4	354 A4	355 A4
		351 E6	351A6	352 E6	352 A6	353 F6	353A6	354 F6	354 A6	355 A6
		351 E8	351A8	352 E8	352 A8	353 F8	353A8	354 F8	354 A8	355 A8
Motoventilatori	n° x Ø	1x350		2x350		3x350		4x350		5x350
Dimensioni	A mm	875		1425		1975		2525		3075
	B mm	580		1130		1680		2230		2780
	C mm	-		-		-		1115		1665
	D mm	-		-		-		1115		1115
Innere Batterieanschlüsse	In tube (mm)	12		16		16		22		28
	Out tube (mm)	22		28		28		35 (F8: 42)		42
Attacco scarico	Ø (GAS)	1		1		1		1		1
Peso netto	kg	22		41		58		77		103

Thermostatisches Ventil mit Aussendruck-Kompensator anwenden

## Anschlußplan der Motorventilatoren

### Achtung

die Motoren sind mit automatisch wiederauflüßbaren Temperaturwächtern ausgestattet.

Vor Anwendung von Drehzahlreglern die Eignung für die Motoren überprüfen; nicht verträgliche Systeme können Lärm und Schäden am Motor hervorrufen; der Hersteller lehnt jede Verantwortung für mit Drehzahlreglern ausgestattete Geräte ab.

Modell GCE	251 E4R 251 E6R 251 E8R	251 E4 251 E6 251 E8	252G4 252G6 252G8	252 E4 252 E6 252 E8	253G4 253G6 253G8	253 E4 253 E6 253 E8	254G4 254G6 254G8	254 E4 254 E6 254 E8	311F4 311F6 311F8	312F4 312F6 312F8	313F4 313F6 313F8	314F4 314F6 314F8					
Motorventilatoren	1 x 250		2 x 250		3 x 250		4 x 250		1 x 315		2 x 315		3 x 315		4 x 315		
Frequenz	Hz	50	60	50	60	50	60	50	60	50	60	50	60	50	60	50	60
Stromaufnahme	A	0,68	-	1,36	-	2,04	-	2,72	-	0,52	0,66	1,04	1,32	1,56	1,98	2,08	2,64
Motorventilatoren	W	95	-	190	-	285	-	380	-	110	148	220	296	330	444	440	592
RPM		1300	1550	1300	1550	1300	1550	1300	1550	1350	1490	1350	1490	1350	1490	1350	1490

Modello GCE	351 E4 351 E6 351 E8	351A4 351A6 351A8	352 E4 352 E6 352 E8	352 A4 352 A6 352 A8	353 F4 353 F6 353 F8	353A4 353A6 353A8	354 F4 354 F6 354 F8	354 A4 354 A6 354 A8	355 A4 355 A6 355 A8		
Motori	1 x 350		2 x 350		3 x 350		4 x 350		5 x 350		
Frequenz	Hz	50	60	50	60	50	60	50	60	50	60
Stromaufnahme	A	0,96	1,08	1,92	2,16	2,88	3,24	3,84	4,32	4,80	5,40
Motorventilatoren	W	185	250	370	500	555	750	740	1000	925	1250
RPM		1420	1660	1420	1660	1420	1660	1420	1660	1420	1660

### Anschlußplan der Motorventilatoren ø 250 mm

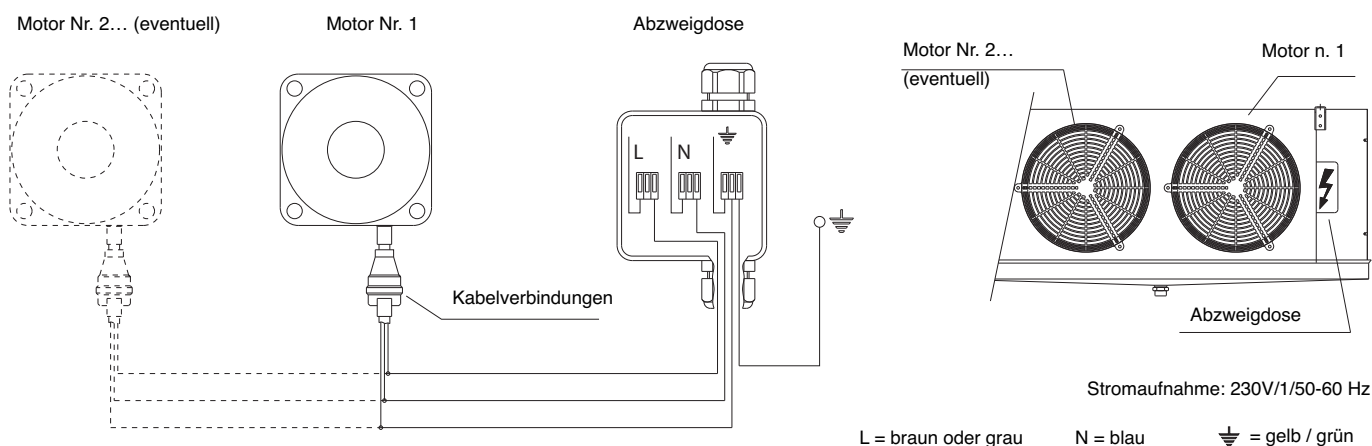

### Anschlußplan der Motorventilatoren ø 315 - 350 mm

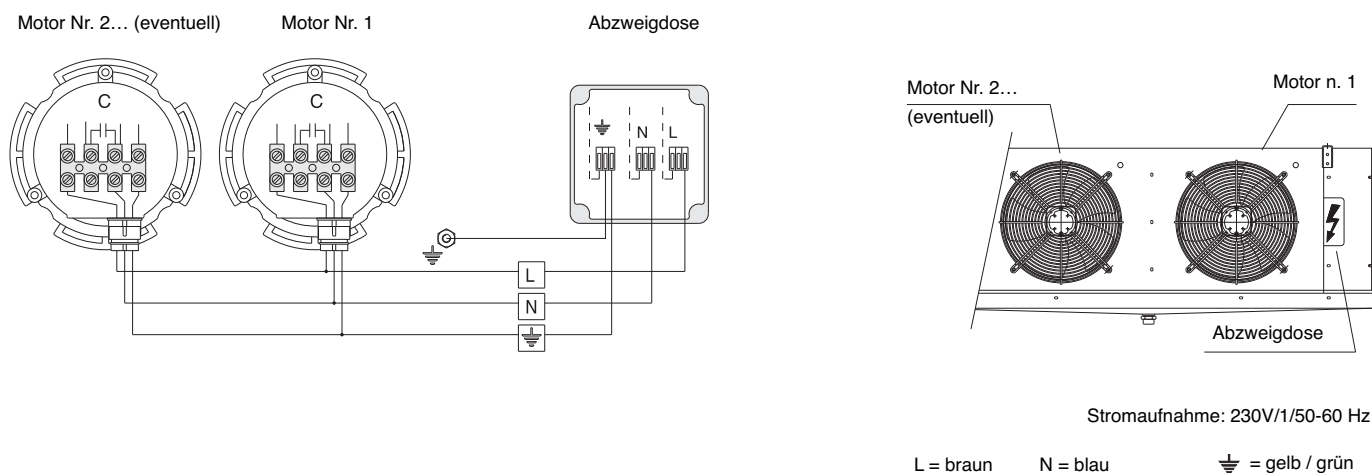

# Ratschläge für einen korrekten Zugang zum Gerät

## Ausbau

1. Tauwasserabflußrohr demontieren.
2. Befestigungsschrauben "A" der Tropfwanne von der inneren Tropfwanne losschrauben.
3. Die selbstbohrenden Schrauben "B" lockern, ohne sie jedoch ganz abzuschrauben und die seitliche Abdeckung abnehmen.

## Zusammenbau

1. Die seitliche Abdeckung mit den Schrauben "B" befestigen.
2. Tropfwanne so positionieren, daß die seitlichen Abdeckungen innen sind und mit den Schrauben "A" befestigen.
3. Tauwasserabflußrohr montieren.

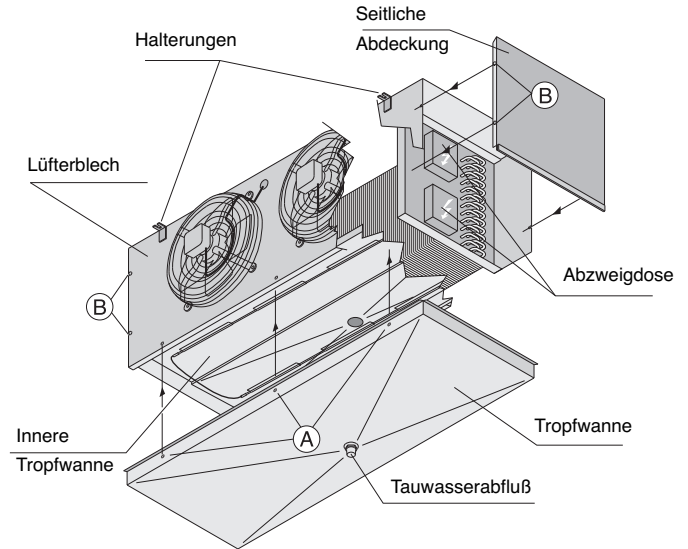

# Anschlußplan und Leistungen der Heizstäbe

**Achtung**  
 die Motoren sind mit automatisch wiederaufrüstbaren Temperaturwächtern ausgestattet.  
 Vor Anwendung von Drehzahlreglern die Eignung für die Motoren überprüfen; nicht verträgliche Systeme können Lärm und Schäden am Motor hervorrufen; der Hersteller lehnt jede Verantwortung für mit Drehzahlreglern ausgestattete Geräte ab.

## Modell mit Flügeldurchmesser 250 mm

### ANSCHLUß 400V/3/50 Hz STANDARD

GCE 251ExR

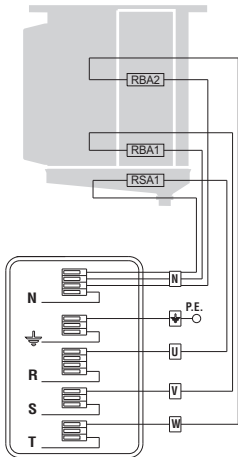
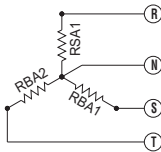

GCE 252Gx  
253Gx  
254Gx

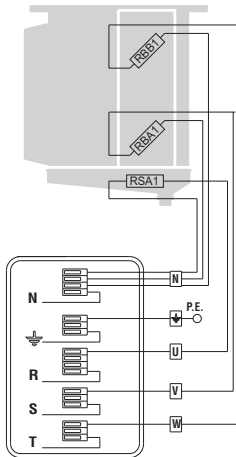
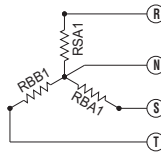

GCE 251Ex  
252Ex  
253Ex  
254Ex

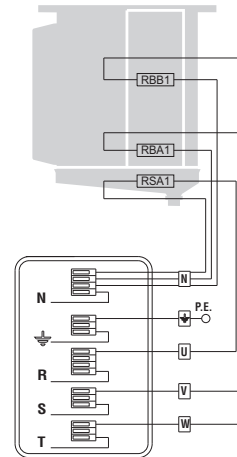
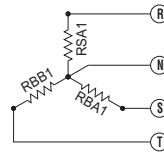

**RBA (1-2)**

Hochleistungsheizstab im Wärmeaustauscher.

**RBB1**

Niederleistungsheizstab im Wärmeaustauscher.

**RSA1**

Hochleistungsheizstab in der inneren Tropfwanne.

Modell GCE "ED" ø 250	251E4R	251E4	252G4	252E4	253G4	253E4	254G4	254E4
	251E6R	251E6	252G6	252E6	253G6	253E6	254G6	254E6
	251E8R	251E8	252G8	252E8	253G8	253E8	254G8	254E8
Rohrreihen	4 RR	4 RR	3 RR	4 RR	3 RR	4 RR	3 RR	4 RR
Gesamtleistung (W)	750	1125	2250	2250	3325	3325	4375	4375



## Anschlußplan und Leistungen der Heizstäbe

### Achtung

die Motoren sind mit automatisch wiederaufrüstbaren Temperaturwächtern ausgestattet.  
Vor Anwendung von Drehzahlreglern die Eignung für die Motoren überprüfen; nicht verträgliche Systeme können Lärm und Schäden am Motor hervorrufen; der Hersteller lehnt jede Verantwortung für mit Drehzahlreglern ausgestattete Geräte ab.

### Modell mit Flügelndurchmesser 250 mm

ANSCHLUß 230V/1/50 Hz **VORZUBEREITEN**

GCE 251ExR

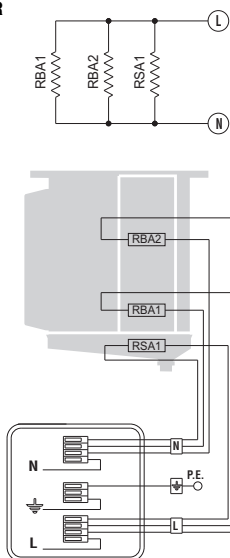

GCE 252Gx  
253Gx  
254Gx

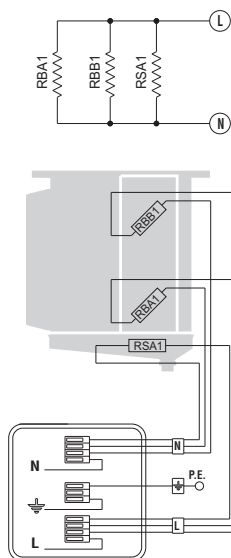

GCE 251Ex  
252Ex  
253Ex  
254Ex

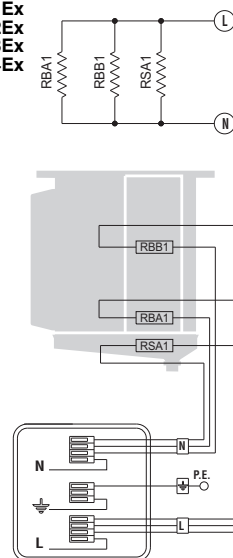

#### RBA (1-2)

Hochleistungsheizstab im Wärmeaustauscher.

#### RBB1

Niederleistungsheizstab im Wärmeaustauscher.

#### RSA1

Hochleistungsheizstab in der inneren Tropfwanne.

Modell GCE "ED" ø 250	251E4R	251E4	252G4	252E4	253G4	253E4	254G4	254E4
	251E6R	251E6	252G6	252E6	253G6	253E6	254G6	254E6
	251E8R	251E8	252G8	252E8	253G8	253E8	254G8	254E8
Rohrreihen	4 RR	4 RR	3 RR	4 RR	3 RR	4 RR	3 RR	4 RR
Gesamtleistung (W)	750	1125	2250	2250	3325	3325	4375	4375

### Modell mit Flügelndurchmesser 315 mm

ANSCHLUß 400V/3/50 Hz  
(standard)

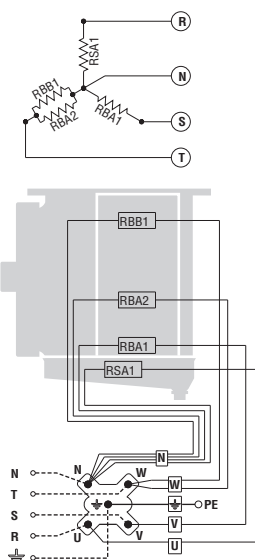

ANSCHLUß 230V/1/50 Hz  
(vorzubereiten)

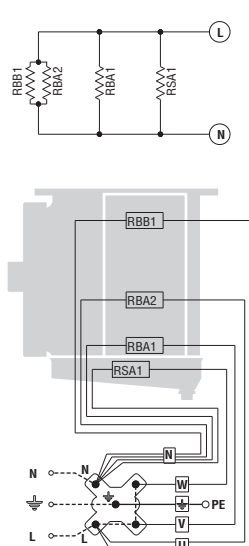

RBA (1-2) Hochleistungsheizstab im Wärmeaustauscher.

RBB1 Niederleistungsheizstab im Wärmeaustauscher.

RSA1 Hochleistungsheizstab in der inneren Tropfwanne.

Modell GCE "ED" ø 315	311F4	312F4	313F4	314F4
	311F6	312F6	313F6	314F6
	311F8	312F8	313F8	314F8
Rohrreihen	5 RR	5 RR	5RR	5 RR
Gesamtleistung (W)	1750	3150	4900	6300

## Anschlußplan und Leistungen der Heizstäbe

### Achtung

die Motoren sind mit automatisch wiederaufrüstbaren Temperaturwächtern ausgestattet.

Vor Anwendung von Drehzahlreglern die Eignung für die Motoren überprüfen; nicht verträgliche Systeme können Lärm und Schäden am Motor hervorrufen; der Hersteller lehnt jede Verantwortung für mit Drehzahlreglern ausgestattete Geräte ab.

### Modell mit Flügeldurchmesser 350 mm

### 4-5 RR standard

ANSCHLUß 400V/3/50 Hz  
(standard)

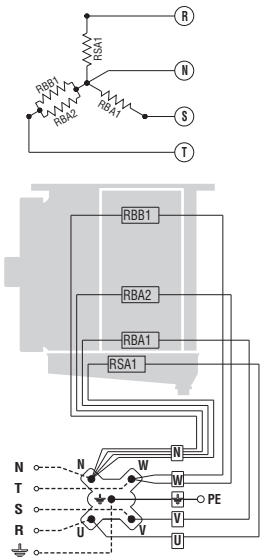

ANSCHLUß 230V/1/50 Hz  
(vorbereiten)

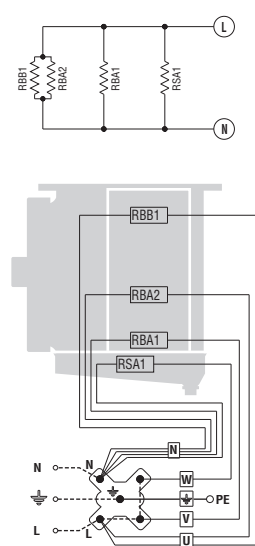

**RBA (1-2)** Hochleistungsheizstab im Wärmeaustauscher.  
**RBB1** Niederleistungsheizstab im Wärmeaustauscher.  
**RSA1** Hochleistungsheizstab in der inneren Tropfwanne.

Modell GCE "ED" ø 350	351 E4	352 E4	353 F4	354 F4
	351 E6	352 E6	353 F6	354 F6
	351 E8	352 E8	353 F8	354 F8
Rohrreihen	4 RR	4 RR	5 RR	5 RR
Gesamtleistung (W)	1750	3150	4900	6300

### Modell mit Flügeldurchmesser 350 mm

### 4-5 RR strengthen

ANSCHLUß 400V/3/50 Hz  
(standard)

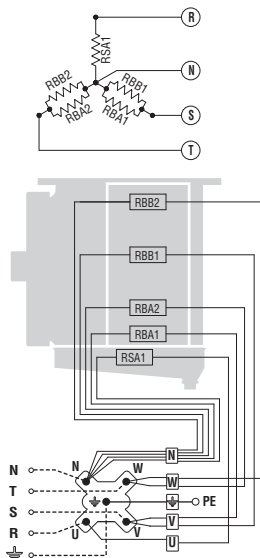

ANSCHLUß 230V/1/50 Hz  
(vorbereiten)

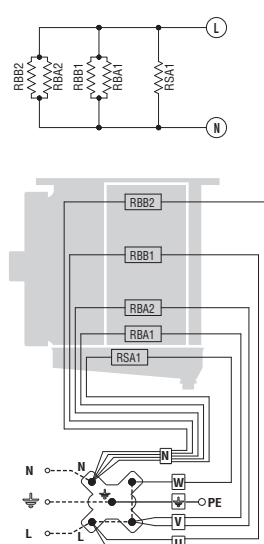

**RBA (1-2)** Hochleistungsheizstab im Wärmeaustauscher.  
**RBB (1-2)** Niederleistungsheizstab im Wärmeaustauscher.  
**RSA1** Hochleistungsheizstab in der inneren Tropfwanne.

Modell GCE "ED" ø 350	351 E4	352 E4	353 F4	354 F4
	351 E6	352 E6	353 F6	354 F6
	351 E8	352 E8	353 F8	354 F8
Rohrreihen	4 RR	4 RR	5 RR	5 RR
Gesamtleistung (W)	2000	3600	5600	7200

## Anschlußplan und Leistungen der Heizstäbe

### Achtung

die Motoren sind mit automatisch wiederaufrüstbaren Temperaturwächern ausgestattet.  
Vor Anwendung von Drehzahlreglern die Eignung für die Motoren überprüfen; nicht verträgliche Systeme können Lärm und Schäden am Motor hervorrufen; der Hersteller lehnt jede Verantwortung für mit Drehzahlreglern ausgestattete Geräte ab.

### Modell mit Flügeldurchmesser 350 mm

### 6RR standard

ANSCHLUß 400V/3/50 Hz  
(standard)

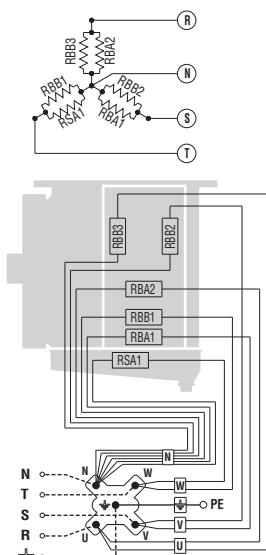

ANSCHLUß 230V/3/50 Hz  
(vorzubereiten)

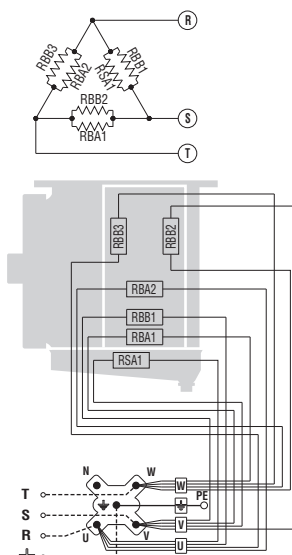

ANSCHLUß 230V/1/50 Hz  
(vorzubereiten)

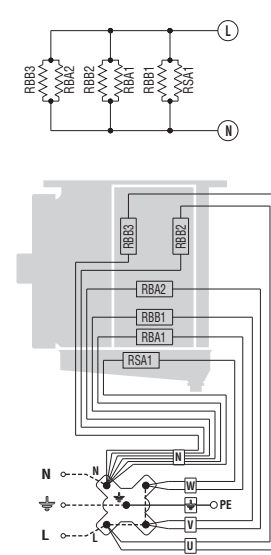

- RBA (1-2) Hochleistungsheizstab im Wärmeaustauscher.
- RBB (1-2-3) Niederleistungsheizstab im Wärmeaustauscher.
- RSA1 Hochleistungsheizstab in der inneren Tropfwanne.

Modell GCE "ED"	351 A4	352 A4	353 A4	354 A4	355 A4
ø 350	351 A6	352 A6	353 A6	354 A6	355 A6
	351 A8	352 A8	353 A8	354 A8	355 A8
Rohrreihen	6 RR	6 RR	6 RR	6 RR	6 RR
Gesamtleistung (W)	2250	4050	6300	8100	9900

Deutsch

### Modell mit Flügeldurchmesser 350 mm

### 6RR strengthen

ANSCHLUß 400V/3/50 Hz  
(standard)

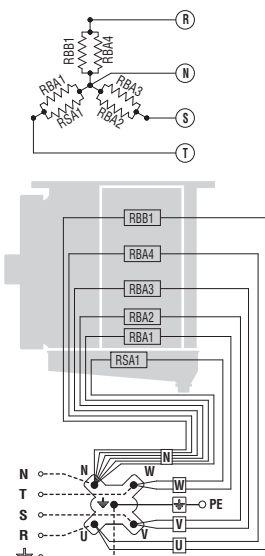

ANSCHLUß 230V/1/50 Hz  
(vorzubereiten)

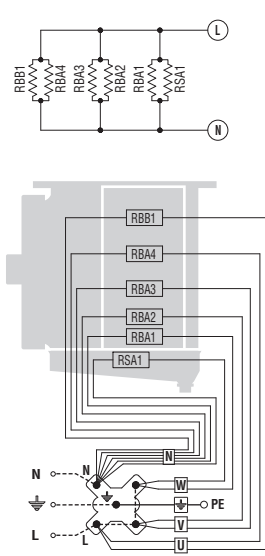

- RBA (1-2-3-4) Hochleistungsheizstab im Wärmeaustauscher.
- RBB1 Niederleistungsheizstab im Wärmeaustauscher.
- RSA1 Hochleistungsheizstab in der inneren Tropfwanne.

Modell GCE "ED"	351 A4	352 A4	353 A4	354 A4	355 A4
ø 350	351 A6	352 A6	353 A6	354 A6	355 A6
	351 A8	352 A8	353 A8	354 A8	355 A8
Rohrreihen	6 RR	6 RR	6 RR	6 RR	6 RR
Gesamtleistung (W)	2750	4950	7700	9900	12100

## Important

1. Keep this manual for the lifespan of model.
2. Read technical manual carefully before installation and prior to any intervention on model.
3. Use model exclusively for the purpose for which it has been designed; misuse exempts manufacturer from any responsibility.

## Inspection - Transport

1. Upon delivery immediately examine condition of model; should damages be detected promptly notify forwarder.
2. During transport of model it is necessary to avoid pressure on packaging and it must be kept in upright position as indicated on package.
3. Unpack model as close as possible to installation site. When packaging is removed from model, care must be exercised in order to avoid damage to parts.
4. In order to avoid injury from the model's sharp edges (e.g. fins) during installation and positioning of model use of special protective gloves is recommended.

## For a proper installation

1. Verify structural bearing of ceiling in relation to the weight of the unit.
2. Verify that the unit is installed horizontally.
3. Ensure an adequate free space (approx. 30% of the inner room volume) to allow a proper intake and exhaust air circulation.

**Particular conditions of installation or operation such as low or beamed rooms, overstorage, obstructed intake and exhaust air circulation and improper ice build-up due to excessive entry of humidity in room may negatively affect the stated performance and may cause defects.**

**Standard models may not be suitable for blast freezer and chill room application.**

4. The models are equipped with axial fan motors, therefore not suitable for duct ventilation systems and cannot sustain extra static air pressure drops.
5. Verify that the operating conditions (temperatures and pressures) are in accordance to those of project.
6. Care must be exercised during the connecting phase in order to avoid possible distortion of the capillary tubes and shifting of the distributor.
7. In the case of more than one model installed at close range it is advisable to avoid alternate defrostings.
8. Fit the appropriate siphons on the condensate drain connections and assess their efficiency in all working temperatures.
9. Avoid installation of the units next to the cold-room doors.
10. Place the end of defrost temperature feeler in the coldest areas of the coil, i.e. the areas that tend to freeze more (at the end of the cycle the unit should be completely ice-free).  
The position of this device cannot be defined in advance, because it varies in accordance to the type cold room and type of installation.
11. Verify that the electrical feed network is in accordance to the electrical features of model.
12. Ensure that all the electric wiring is in compliance with the standards in force.
13. The units are predisposed for ground wiring connection.  
The unit installer and/or plant operator must ensure the presence of an efficient earthing connection to protect against indirect electric contacts.  
The electric heating elements eventually used for defrosting

are housed in junction boxes made of thermoplastic material, with protection rating IP 54.

Upon request, models can be supplied with coils, defrosting units and fan motors different from the standard ones.





14. The protective film is to be removed from model upon completion of installation.
15. Access to model, for any type of intervention, is reserved to qualified personnel as per regulations in force.

## General Maintenance

1. Periodically inspect fastenings, electrical connections and connections to cooling installation.
2. It is necessary to arrange periodical cleaning of unit in order to avoid deposits of toxic substances. Use of mild detergent is recommended; avoid use of solvents, aggressive, abrasive or ammonia-based agents.
3. When replacing electric heaters take particular care during installation in order to avoid damage to the vulcanization; correctly reset wiring and existing fastening systems to avoid possible movement during operation.

**The above-mentioned operations are to be carried out by qualified personnel only.**

## Hazards / Risks

1.  Electric shock. The model is equipped with fan motors and electric defrost heaters. The supply voltage is 400 V AC. It is important to use electrical safety systems that are in compliance to the regulations in force.
2.  Burns. The surface of the electric defrost heaters can reach the temperature of 350 ° C.
3.  Cuts. The heat exchanger is made with fins with sharp edges and the casing is made of sheet metal parts.
4.  Parts in motion. The model is equipped with fan motors fitted with external protection.
5.  Crushing. The weight of unit may exceed 100 kg.

## Reference standards

- MACHINES DIRECTIVE 2006/42/EC
- LOW-VOLTAGE DIRECTIVE 2014/35/UE
- ELECTROMAGNETIC COMPATIBILITY DIR. 2014/30/UE
- PED DIRECTIVE 2014/68/UE
- ERP DIRECTIVE 2009/125/EC

### Caution

Before carrying out maintenance on unit, make sure that the electric feed is disconnected from main power source: the electric parts may be connected to an automatic control system.

## Instructions for a correct installation

### Minimum distance from wall on heater side - Minimum distance from wall on suction side

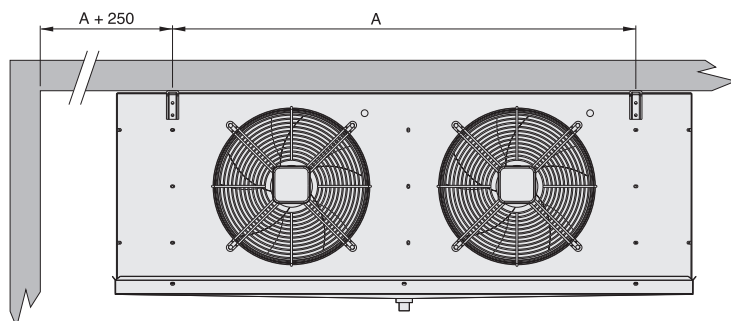

During the installation phase observe the minimum dimension A+250 as to allow an adequate space for the removal and fitting of heaters.

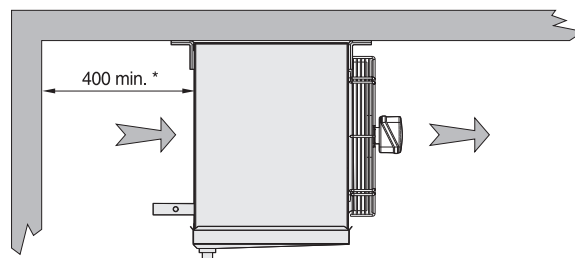

During the installation phase observe the minimum distance of 400 mm as to allow proper functioning of motor.

## Manufacturing and dimensional features

### Model with ø 250 mm fan motor

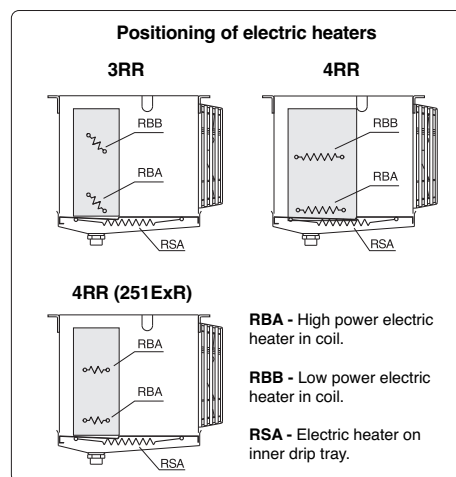
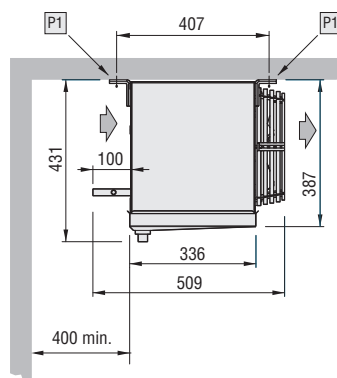
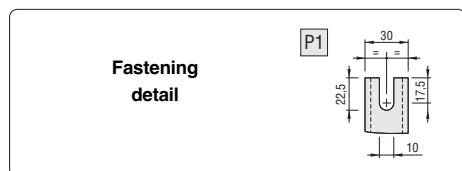
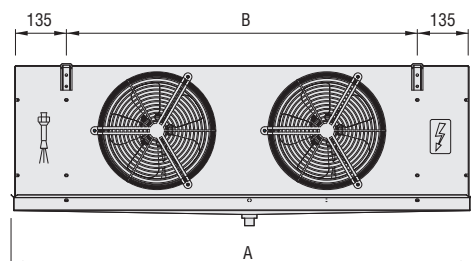

Model	GCE	251 E4R	251 E4	252 G4	252 E4	253 G4	253 E4	254 G4	254 E4
		251 E6R	251 E6	252 G6	252 E6	253 G6	253 E6	254 G6	254 E6
		251 E8R	251 E8	252 G8	252 E8	253 G8	253 E8	254 G8	254 E8
Fan motors	n° x Ø mm	1x250	1x250	2x250	2x250	3x250	3x250	4x250	4x250
Dimensions	A	674	774	1224	1224	1674	1674	2124	2124
	B	380	480	930	930	1380	1380	1830	1830
Coil connections	In tube (mm)	12	12	12	12	12	12	12	16
	Out tube (mm)	12	12	22	22	22	22	22 (G4: 28)	28
Drain connection	Ø (GAS)	1"	1"	1"	1"	1"	1"	1"	1"
Net weight	kg	13	14,5	21,5	24	30	33	38	41,5

Use thermostatic valve with external pressure equalizer

# Manufacturing and dimensional features

## Model with ø 315 mm fan motor

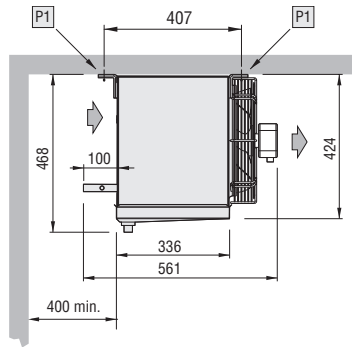
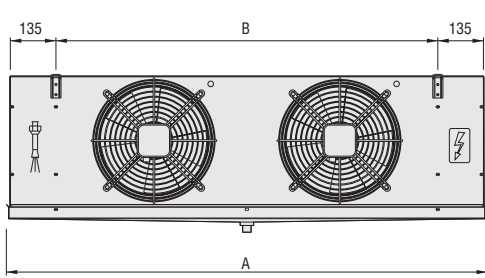

### Positioning of electric heaters

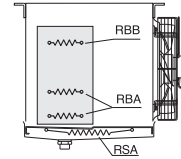

RBA - High power electric heater in coil.  
RBB - Low power electric heater in coil.  
RSA - Electric heater on inner drip tray.

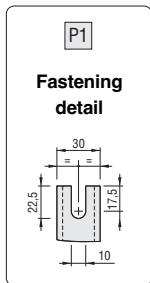

Model	GCE	311F4 311F6 311F8	312F4 312F6 312F8	313F4 313F6 313F8	314F4 314F6 314F8
Fan motors	n° x Ø mm	1x315	2x315	3x315	4x315
Dimensions	A	874	1424	1974	2524
	B	580	1130	1680	2230
Coil connections	In tube (mm)	12	12	16	16 (F4: 22)
	Out tube (mm)	22	28	28	28 (F8: 35)
Drain connection	Ø (GAS)	1"	1"	1"	1"
Net weight	kg	20	34	47,5	61

Use thermostatic valve with external pressure equalizer

## Model with ø 350 mm fan motor

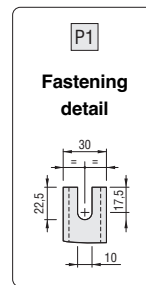
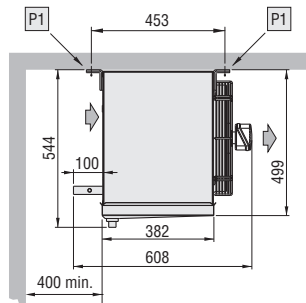
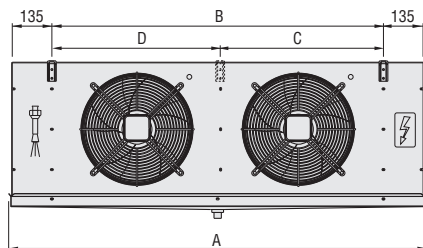

### Positioning of electric heaters

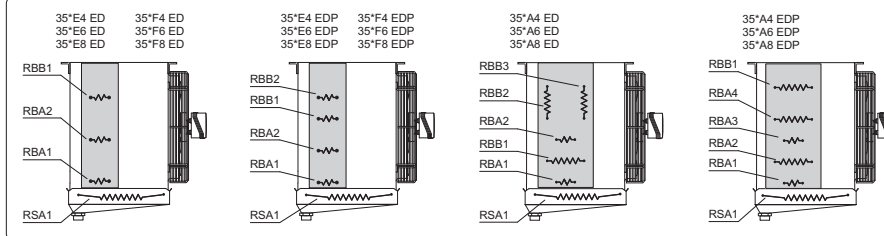

RBA - High power electric heater in coil.  
RBB - Low power electric heater in coil.  
RSA - Electric heater on inner drip tray.

Modello	GCE	351 E4 351 E6 351 E8	351A4 351A6 351A8	352 E4 352 E6 352 E8	352 A4 352 A6 352 A8	353 F4 353 F6 353 F8	353A4 353A6 353A8	354 F4 354 F6 354 F8	354 A4 354 A6 354 A8	355 A4 355 A6 355 A8
Motoventilatori	n° x Ø	1x350	1x350	2x350	2x350	3x350	3x350	4x350	4x350	5x350
Dimensioni	A mm	875	875	1425	1425	1975	1975	2525	2525	3075
	B mm	580	580	1130	1130	1680	1680	2230	2230	2780
	C mm	-	-	-	-	-	-	1115	1115	1665
	D mm	-	-	-	-	-	-	1115	1115	1115
Coil connections	In tube (mm)	12	12	16	16	16 (F4: 22)	22	22	28	28
	Out tube (mm)	22	22	28	28	28 (F8: 35)	35	35 (F8: 42)	42	42
Attacco scarico	Ø (GAS)	1	1	1	1	1	1	1	1	1
Peso netto	kg	22	26,5	41	48	58	63	77	83,5	103

Use thermostatic valve with external pressure equalizer

## Fan motor connection scheme

### Important

The motors are equipped with inner thermal protection with automatic reconnection.  
 Before using motor speed control systems verify the compatibility with the motors;  
 Non compatible systems may damage motors or increase noise level; the manufacturer will not be responsible for model performance with speed control systems.

Modell GCE	251 E4R 251 E6R 251 E8R	251 E4 251 E6 251 E8	252G4 252G6 252G8	252 E4 252 E6 252 E8	253G4 253G6 253G8	253 E4 253 E6 253 E8	254G4 254G6 254G8	254 E4 254 E6 254 E8	311F4 311F6 311F8	312F4 312F6 312F8	313F4 313F6 313F8	314F4 314F6 314F8					
Fan motors	1 x 250		2 x 250		3 x 250		4 x 250		1 x 315		2 x 315		3 x 315		4 x 315		
Frequency	Hz	50	60	50	60	50	60	50	60	50	60	50	60	50	60	50	60
Fan motors	A	0,68	-	1,36	-	2,04	-	2,72	-	0,52	0,66	1,04	1,32	1,56	1,98	2,08	2,64
absorption	W	95	-	190	-	285	-	380	-	110	148	220	296	330	444	440	592
RPM		1300	1550	1300	1550	1300	1550	1300	1550	1350	1490	1350	1490	1350	1490	1350	1490

Modell GCE	351 E4 351 E6 351 E8	351A4 351A6 351A8	352 E4 352 E6 352 E8	352 A4 352 A6 352 A8	353 F4 353 F6 353 F8	353A4 353A6 353A8	354 F4 354 F6 354 F8	354 A4 354 A6 354 A8	355 A4 355 A6 355 A8		
Fan motors	1 x 350		2 x 350		3 x 350		4 x 350		5 x 350		
Frequency	Hz	50	60	50	60	50	60	50	60	50	60
Fan motors	A	0,96	1,08	1,92	2,16	2,88	3,24	3,84	4,32	4,80	5,40
absorption	W	185	250	370	500	555	750	740	1000	925	1250
RPM		1420	1660	1420	1660	1420	1660	1420	1660	1420	1660

### Ø 250 mm fan motor connection scheme

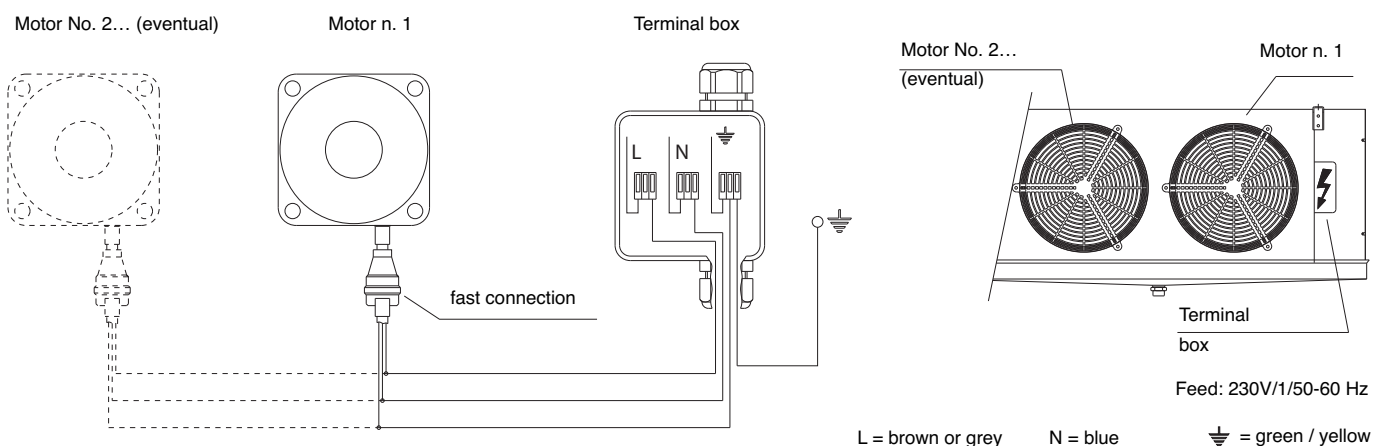

### Ø 315 - 350 mm fan motor connection scheme

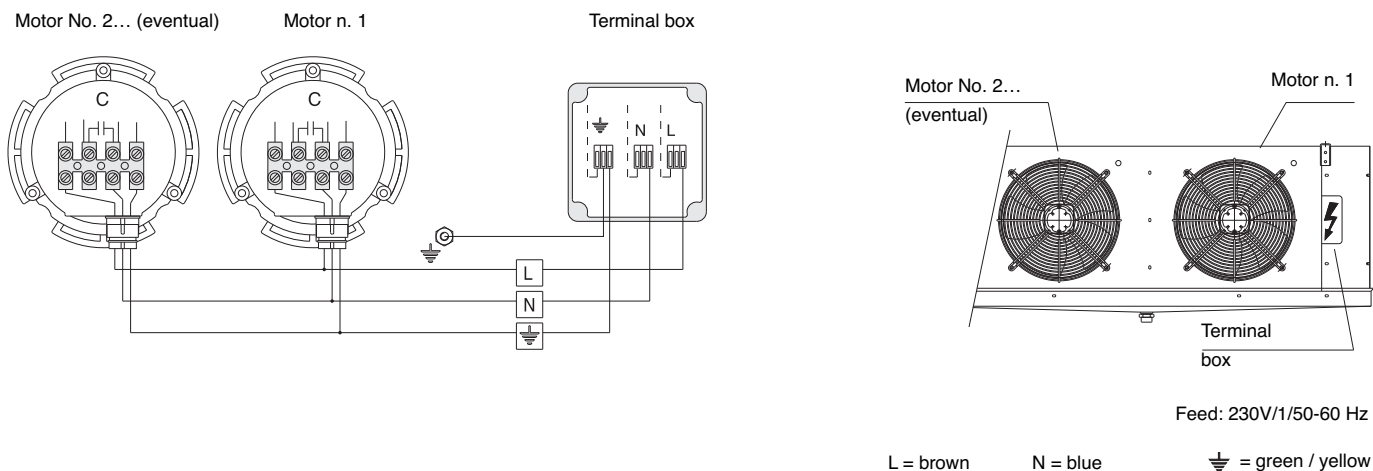

## Recommendations for a proper access to model

### Access

1. Remove drain connection.
2. Verify that drip tray is free from ice build-up before removing it by unfastening screws "A".
3. Loosen self-threading screws "B", without removing completely, then slip off side panel.

### Remounting

1. Reposition the side panel and fasten with screws "B".
2. Reposition drip tray, ensuring that the side panels are placed on the inside and fasten with screws "A".
3. Reconnect the drain connection.

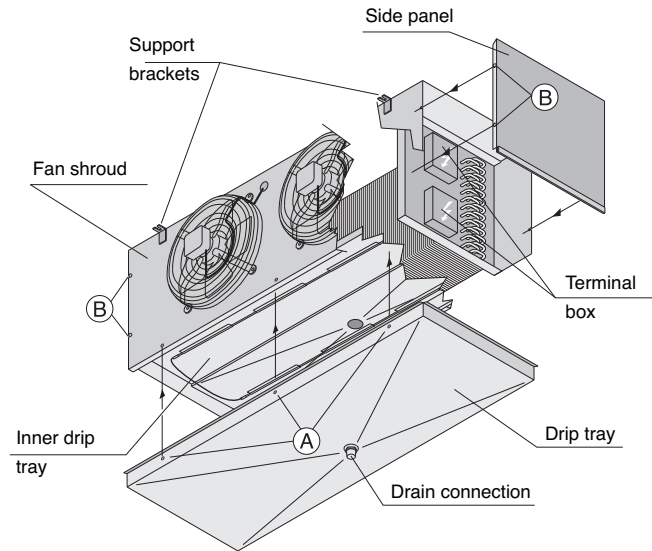

## Electric heater connection schemes and electric power

### Important

Application of adequate thermal control systems on feeder lines is mandatory. Performance of all electric heaters must be periodically controlled to avoid damage due to ice build-up. the manufacturer is not liable in any way for defects caused by non detected malfunctions.

### Model with ø 250 mm fan motor

#### CONNECTION 400V/3/50 Hz PRESET

GCE 251ExR

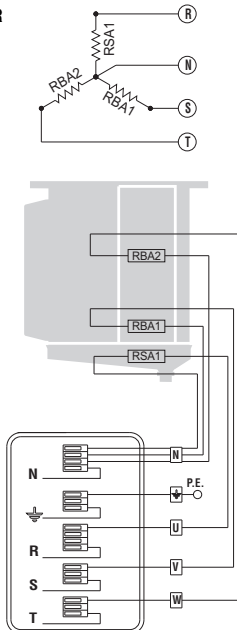

GCE 252Gx  
253Gx  
254Gx

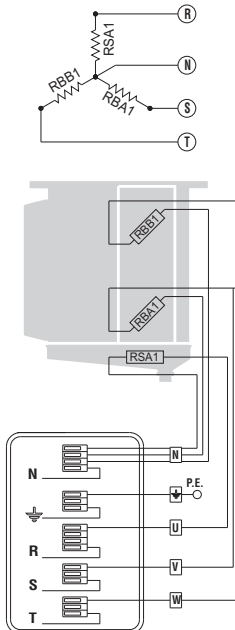

GCE 251Ex  
252Ex  
253Ex  
254Ex

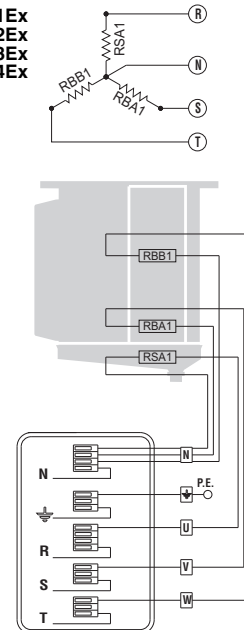

#### RBA (1-2)

High power electric heaters in coil.

#### RBB1

Low power electric heaters in coil.

#### RSA1

High power electric heater on inner drip tray.

Model GCE "ED" ø 250	251E4R 251E6R 251E8R	251E4 251E6 251E8	252G4 252G6 252G8	252E4 252E6 252E8	253G4 253G6 253G8	253E4 253E6 253E8	254G4 254G6 254G8	254E4 254E6 254E8
Rows	4 RR	4 RR	3 RR	4 RR	3 RR	4 RR	3 RR	4 RR
Total power (W)	750	1125	2250	2250	3325	3325	4375	4375



## Electric heater connection schemes and electric power

### Important

Application of adequate thermal control systems on feeder lines is mandatory.  
Performance of all electric heaters must be periodically controlled to avoid damage due to ice build-up.  
The manufacturer is not liable in any way for defects caused by non-detected malfunctions.

### Model with ø 250 mm fan motor

CONNECTION 230V/1/50 Hz TO SET

GCE 251ExR

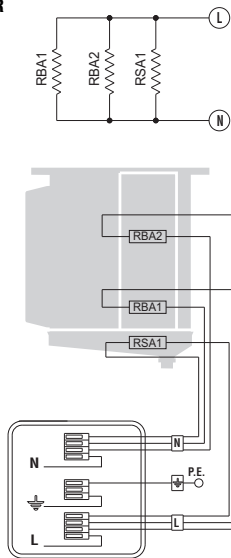

GCE 252Gx  
253Gx  
254Gx

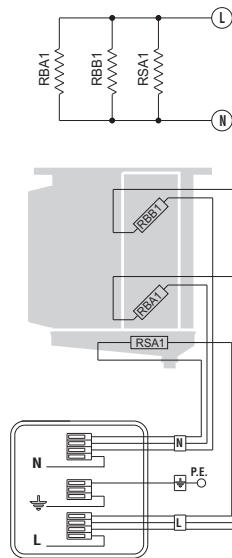

GCE 251Ex  
252Ex  
253Ex  
254Ex

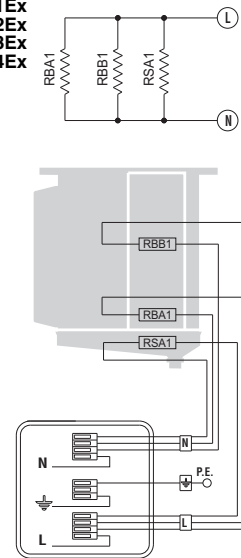

#### RBA (1-2)

High power electric heaters in coil.

#### RBB1

Low power electric heaters in coil.

#### RSA1

High power electric heater on inner drip tray.

Model GCE "ED" ø 250	251E4R 251E6R 251E8R	251E4 251E6 251E8	252G4 252G6 252G8	252E4 252E6 252E8	253G4 253G6 253G8	253E4 253E6 253E8	254G4 254G6 254G8	254E4 254E6 254E8
Rows	4 RR	4 RR	3 RR	4 RR	3 RR	4 RR	3 RR	4 RR
Total power (W)	750	1125	2250	2250	3325	3325	4375	4375

### Model with ø 315 mm fan motor

400V/3/50 Hz CONNECTION  
(preset)

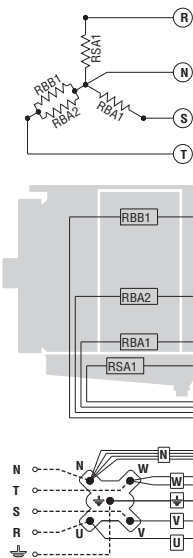

230V/1/50 Hz CONNECTION  
(to set)

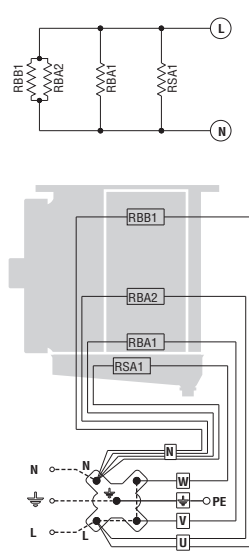

**RBA (1-2)** High power electric heaters in coil.

**RBB1** Low power electric heaters in coil.

**RSA1** High power electric heater on inner drip tray.

Model GCE "ED" ø 315	311F4 311F6 311F8	312F4 312F6 312F8	313F4 313F6 313F8	314F4 314F6 314F8
Rows	5 RR	5 RR	5 RR	5 RR
Total power (W)	1750	3150	4900	6300

# Electric heater connection schemes and electric power

**Important**  
 Application of adequate thermal control systems on feeder lines is mandatory.  
 Performance of all electric heaters must be periodically controlled to avoid damage due to ice build-up.  
 the manufacturer is not liable in any way for defects caused by non detected malfunctions.

## Model with ø 350 mm fan motor 4-5 RR standard

400V/3/50 Hz CONNECTION  
(preset)

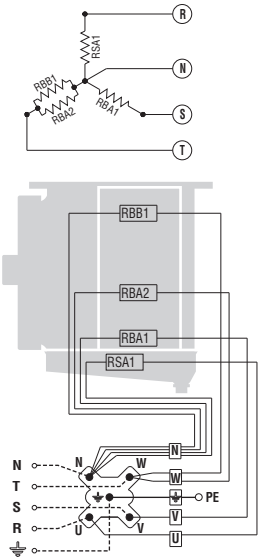

230V/1/50 Hz CONNECTION  
(to set)

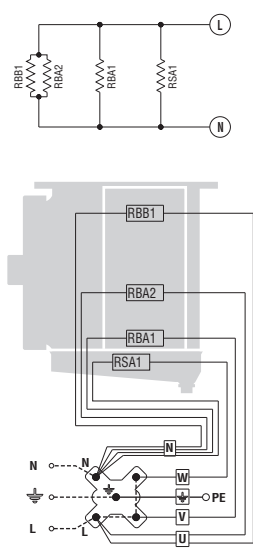

**RBA (1-2)** High power electric heaters in coil.  
**RBB1** Low power electric heaters in coil.  
**RSA1** High power electric heater on inner drip tray.

Model GCE "ED" ø 350	351 E4 351 E6 351 E8	352 E4 352 E6 352 E8	353 F4 353 F6 353 F8	354 F4 354 F6 354 F8
Rows	4 RR	4 RR	5 RR	5 RR
Total power (W)	1750	3150	4900	6300

## Model with ø 350 mm fan motor 4-5 RR strengthen

400V/3/50 Hz CONNECTION  
(preset)

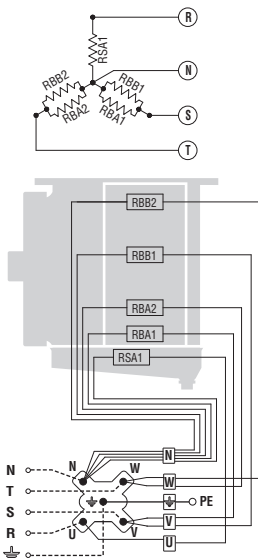

230V/1/50 Hz CONNECTION  
(to set)

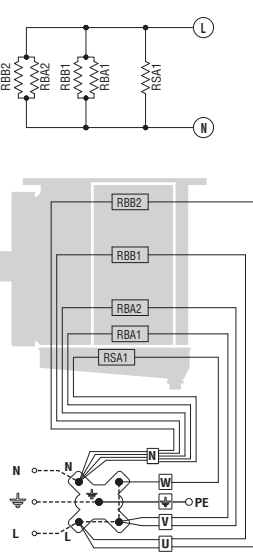

**RBA (1-2)** High power electric heaters in coil.  
**RBB (1-2)** Low power electric heaters in coil.  
**RSA1** High power electric heater on inner drip tray.

Model GCE "ED" ø 350	351 E4 351 E6 351 E8	352 E4 352 E6 352 E8	353 F4 353 F6 353 F8	354 F4 354 F6 354 F8
Rows	4 RR	4 RR	5 RR	5 RR
Total power (W)	2000	3600	5600	7200

## Electric heater connection schemes and electric power

### Important

Application of adequate thermal control systems on feeder lines is mandatory.  
Performance of all electric heaters must be periodically controlled to avoid damage due to ice build-up.  
the manufacturer is not liable in any way for defects caused by non detected malfunctions.

### Model with ø 350 mm fan motor

### 6 RR standard

400V/3/50 Hz CONNECTION  
(preset)

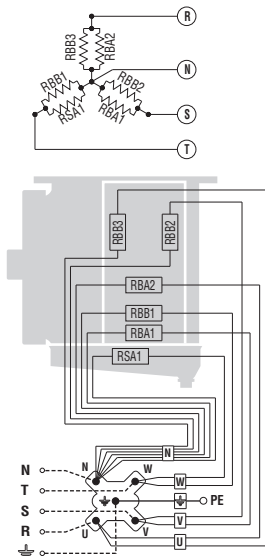

230V/3/50 Hz CONNECTION  
(to set)

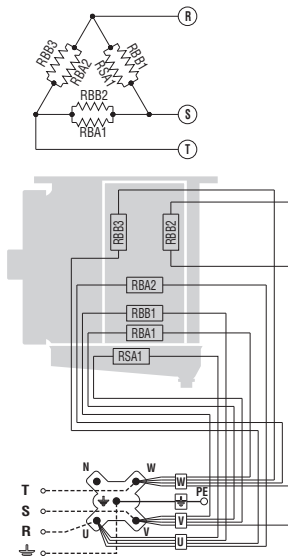

230V/1/50 Hz CONNECTION  
(to set)

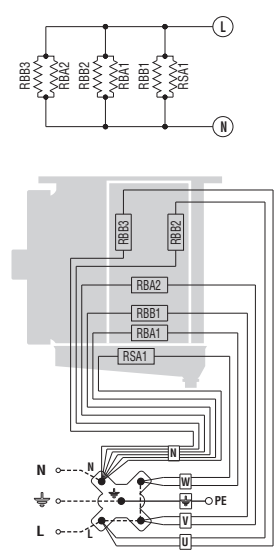

- RBA (1-2) High power electric heater in coil.
- RBB (1-2-3) Low power electric heaters in coil.
- RSA1 High power electric heater on inner drip tray.

Model GCE "ED" ø 350	351 A4 351 A6 351 A8	352 A4 352 A6 352 A8	353 A4 353 A6 353 A8	354 A4 354 A6 354 A8	355 A4 355 A6 355 A8
Rows	6 RR	6 RR	6 RR	6 RR	6 RR
Total power (W)	2250	4050	6300	8100	9900

### Model with ø 350 mm fan motor

### 6 RR strengthen

400V/3/50 Hz CONNECTION  
(preset)

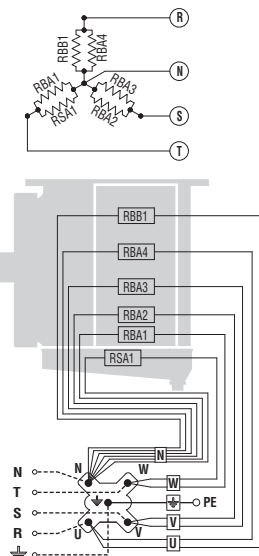

230V/1/50 Hz CONNECTION  
(to set)

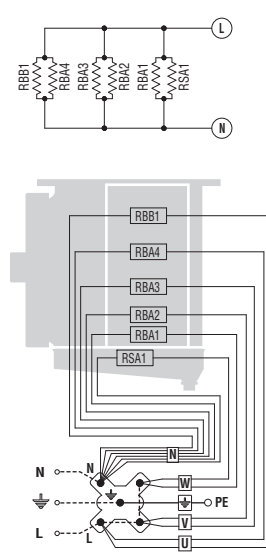

- RBA (1-2-3-4) High power electric heaters in coil.
- RBB1 Low power electric heaters in coil.
- RSA1 High power electric heater on inner drip tray.

Model GCE "ED" ø 350	351 A4 351 A6 351 A8	352 A4 352 A6 352 A8	353 A4 353 A6 353 A8	354 A4 354 A6 354 A8	355 A4 355 A6 355 A8
Rows	6 RR	6 RR	6 RR	6 RR	6 RR
Total power (W)	2750	4950	7700	9900	12100

English

## Advertencias

1. Conservar el presente manual técnico, mientras la unidad esté en funcionamiento.
2. Leer con atención el manual antes de instalar la unidad y antes de cualquier intervención en la misma.
3. Utilizar la unidad exclusivamente para las aplicaciones que ha sido proyectada. La utilización no adecuada libera el constructor de cualquier responsabilidad.

## Inspección - Transporte

1. En fase de recepción del modelo, controlar de inmediato su estado; notificar enseguida cualquier daño a la compañía de transporte.
2. Durante el transporte no es correcto presionar el embalaje imprópiamente, este se tendrá que mantener siempre en la posición indicada en el mismo.
3. Desembalar la unidad cerca del lugar de la instalación. Una vez desembalada, evitar cualquier golpe en los componentes.
4. Durante la instalación y el desplazamiento de la unidad, utilizar guantes de protección adecuados para evitar heridas con las partes afiladas de la unidad (ej. aletas).

## Condiciones a verificar para una correcta puesta en marcha

1. Verificar la capacidad de la estructura de sujeción con respecto al peso del aparato.
2. Verificar que el modelo sea instalado horizontalmente.
3. Asegurar un volumen libre adecuado (cerca del 30% del volumen interno de la cámara) para una correcta circulación del aire, tanto en aspiración como en descarga.

**Particulares condiciones de instalación o funcionamiento como cámaras de altura reducida, vigas en techo, stock excesivo, impedimento a la salida o a la aspiración del aire, formación imprópia de escarcha debido a excesiva introducción de humedad en la cámara, pueden influenciar negativamente los rendimientos declarados de las unidades y generar defectos y problemas. Los modelos standard no se pueden utilizar en tuneles o cámaras de surgelación o congelamiento rápido.**

4. Los modelos son provistos de motores axiales, no aptos para ser canalizados o, en cada caso, a soportar presiones estáticas fuera de lo normal.
5. Verificar que las condiciones de funcionamiento (temperatura y presión) sean conformes a las que figuran en el proyecto.
6. Prestar especial cuidado en la fase de conexión con el fin de que no se deformen los tubos capilares y no se modifique la posición del distribuidor.
7. En caso de varios modelos instalados a poca distancia uno del otro, evitar los desescarches alternos.
8. Instalar en los desagües el sifón necesario y verificar su funcionamiento en todas las temperaturas de utilización.
9. Evitar la instalación de los aeroevaporadores cerca de las puertas de las cámaras.
10. Colocar la sonda de temperatura de final de desescarche en la parte más fría de los intercambiadores o sea en la parte del intercambiador donde se deposita mayormente el hielo (al final del ciclo no tiene que quedarse hielo en los modelos)  
La posición de este dispositivo no se puede determinar antes porque puede cambiar en función del tipo de cámara y del tipo de instalación.
11. Verificar que la línea eléctrica de alimentación sea la adecuada a las características eléctricas de la unidad.
12. Asegurarse que todas las conexiones eléctricas sean de acuerdo con las normas vigentes.
13. Las unidades están preparadas para la conexión eléctrica a tierra. El instalador y/o el usuario de la unidad tienen que garantizar la presencia de una conexión a tierra eficiente y protegida contra

los contactos eléctricos indirectos. Las resistencias eventualmente empleadas para el desescarche se encuentran alojadas en una caja de derivación de material termoplástico y presentan un grado de protección IP 54. A partir de la solicitud del cliente, pueden suministrarse con intercambiadores, dispositivos de desescarche y motoventiladores diferentes de los estándares.

14. Después de haber instalado la unidad quitar la película de plástico de protección de la misma.
14. La accesibilidad al aparato, por cualquier tipo de intervención, debe ser reservada al personal cualificado, responsable de la instalación, según las normas vigentes.

## Manutención general

1. Verificar periódicamente las fijaciones, las conexiones eléctricas y también las conexiones de la instalación frigorífica.
2. Proceder a la limpieza periódica del aparato, para evitar acumulaciones de sustancias nocivas. Se aconseja el uso de agua normal con jabón, evitando disolventes o agentes agresivos, abrasivos o con amoníaco.
3. En el caso de sustitución de las resistencias eléctricas, tener especial cuidado en la fase de montaje para evitar dañar las partes vulcanizadas; restablecer correctamente las conexiones y los sistemas de sujeción existentes para evitar vibraciones de las resistencias durante el funcionamiento.

**Todas estas operaciones deben ser realizadas por personal especializado y cualificado.**

## Peligros

1.  Peligro de electrocución. El modelo está provisto de electroventiladores y resistencias eléctricas de desescarche. La tensión de alimentación es de 400V AC. Utilizar sistemas de seguridad eléctrica previstos por la normativa vigente.
2.  Peligro de gestión. Las resistencias eléctricas de desescarche pueden alcanzar temperaturas superficiales de 350 °C.
3.  Peligro de cortarse. Los intercambiadores de calor son constituidos de aletas con bordes afilados y carrozado con partes de laminado.
4.  Peligros para las partes en movimiento. El modelo está provisto de electroventiladores dotados de rejilla de protección externa.
5.  Peligro de aplastamiento. El modelo puede pesar más de 100 kg.

## Normas de referencia

- DIRECTIVA MAQUINAS 2006/42/EC
- DIRECTIVA BAJA TENSION 2014/35/UE
- DIRECTIVA COMP. ELECTROMAGNETICA 2014/30/UE
- DIRECTIVA PED 2014/68/UE
- DIRECTIVA ERP 2009/125/EC

### Atención

Antes de efectuar cualquier intervención de manutención, comprobar que la alimentación eléctrica ha sido desconectada de la fuente principal: los motores y resistencias pueden ser conectados en un control automático.

## Advertencias para una correcta instalación

### Distancia mínima lateral de la pared lado resistencias - Distancia mínima de la pared lado aspiración

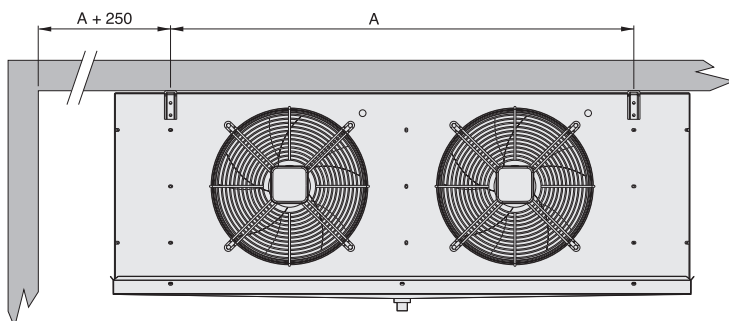

En el proceso de montaje respetar la medida mínima A+250 mm para poder sacar/entrar las resistencias.

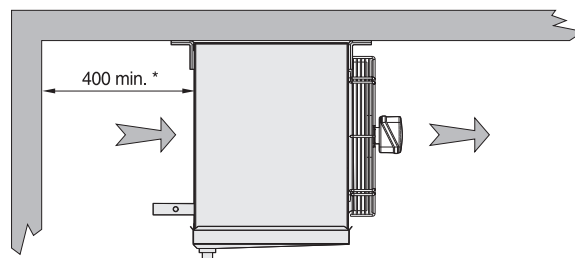

En el proceso de montaje respetar la medida mínima de 400 mm para un buen funcionamiento del motor.

## Características constructivas y dimensionales

### Modelo con helice ø 250 mm

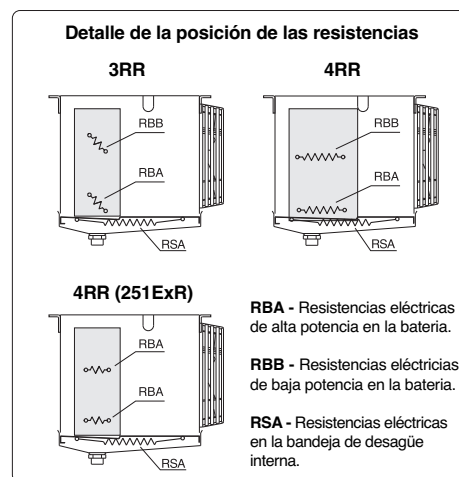
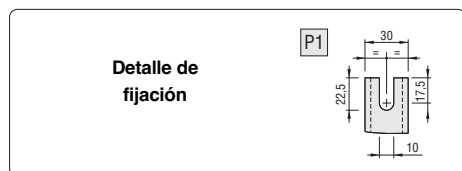
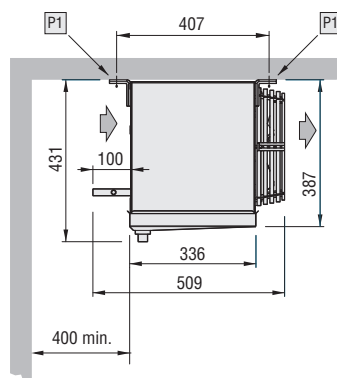
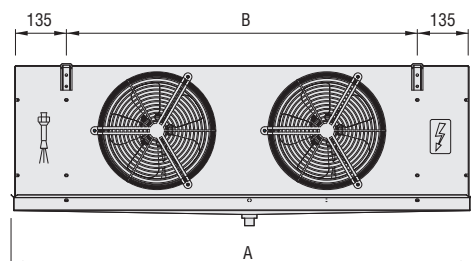

Modelo	GCE	251 E4R	251 E4	252 G4	252 E4	253 G4	253 E4	254 G4	254 E4
		251 E6R	251 E6	252 G6	252 E6	253 G6	253 E6	254 G6	254 E6
		251 E8R	251 E8	252 G8	252 E8	253 G8	253 E8	254 G8	254 E8
Motoventiladores	n° x Ø mm	1x250	1x250	2x250	2x250	3x250	3x250	4x250	4x250
Dimensiones	A	674	774	1224	1224	1674	1674	2124	2124
	B	380	480	930	930	1380	1380	1830	1830
Conexiones batería	In tube (mm)	12	12	12	12	12	12	12	16
	Out tube (mm)	12	12	22	22	22	22	22 (G4: 28)	28
Conexión desagüe	Ø (GAS)	1"	1"	1"	1"	1"	1"	1"	1"
Peso neto	kg	13	14,5	21,5	24	30	33	38	41,5

Emplear válvula de expansión con equilibrador de presión externo

# Características constructivas y dimensionales

## Modelo con helice ø 315 mm

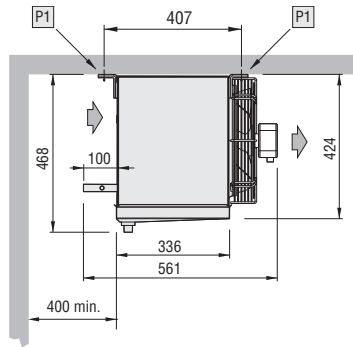
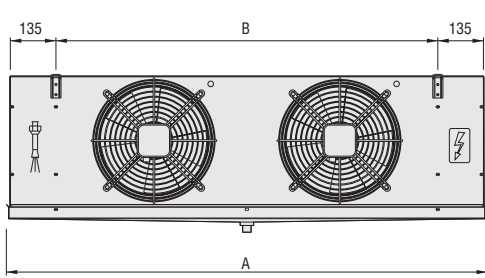

Detalle de la posición de las resistencias

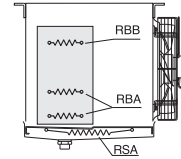

**RBA** - Resistencias eléctricas de alta potencia en la batería.  
**RBB** - Resistencias eléctricas de baja potencia en la batería.  
**RSA** - Resistencias eléctricas en la bandeja de desagüe interna.

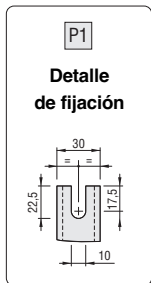

Modelo	GCE	311F4 311F6 311F8	312F4 312F6 312F8	313F4 313F6 313F8	314F4 314F6 314F8
Motoventiladores	n° x Ø mm	1x315	2x315	3x315	4x315
Dimensiones	A	874	1424	1974	2524
	B	580	1130	1680	2230
Conexiones batería	In tube (mm)	12	12	16	16 (F4: 22)
	Out tube (mm)	22	28	28	28 (F8: 35)
Conexión desagüe	Ø (GAS)	1"	1"	1"	1"
Peso neto	kg	20	34	47,5	61

Emplear válvula de expansión con equilibrador de presión externo

## Modelo con helice ø 350 mm

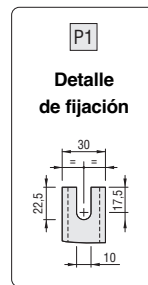
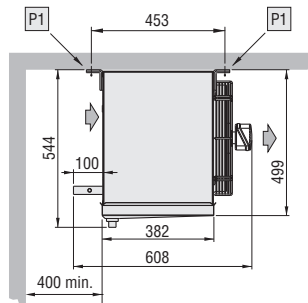
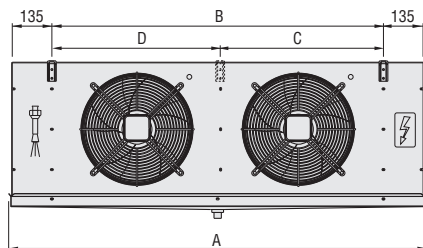

Detalle de la posición de las resistencias

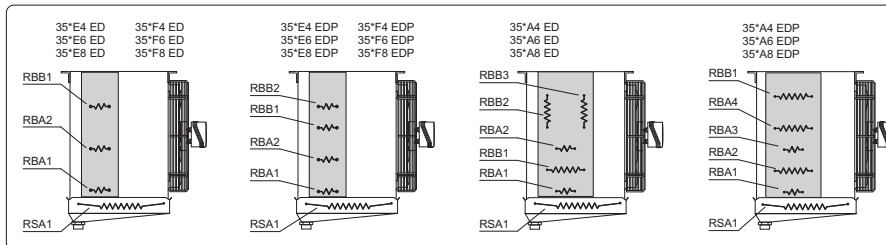

**RBA** - Resistencias eléctricas de alta potencia en la batería.  
**RBB** - Resistencias eléctricas de baja potencia en la batería.  
**RSA** - Resistencias eléctricas en la bandeja de desagüe interna.

Modello	GCE	351 E4 351 E6 351 E8	351A4 351A6 351A8	352 E4 352 E6 352 E8	352 A4 352 A6 352 A8	353 F4 353 F6 353 F8	353A4 353A6 353A8	354 F4 354 F6 354 F8	354 A4 354 A6 354 A8	355 A4 355 A6 355 A8
Motoventilatori	n° x Ø	1x350	1x350	2x350	2x350	3x350	3x350	4x350	4x350	5x350
Dimensioni	A mm	875	875	1425	1425	1975	1975	2525	2525	3075
	B mm	580	580	1130	1130	1680	1680	2230	2230	2780
	C mm	-	-	-	-	-	-	1115	1115	1665
	D mm	-	-	-	-	-	-	1115	1115	1115
Conexiones batería	In tube (mm)	12	12	16	16	16 (F4: 22)	22	22	28	28
	Out tube (mm)	22	22	28	28	28 (F8: 35)	35	35 (F8: 42)	42	42
Attacco scarico	Ø (GAS)	1	1	1	1	1	1	1	1	1
Peso netto	kg	22	26,5	41	48	58	63	77	83,5	103

Emplear válvula de expansión con equilibrador de presión externo

## Esquema de conexión motoventiladores

### Atención

Los motores van provistos de termocontactos de protección internos con rearme automático. Antes de utilizar sistemas de regulación del número de vueltas de los motores, verificar si son compatibles con los motores; sistemas no compatibles pueden causar ruidos y dañar los mismos; el fabricante no responde de los rendimiento de los modelos provistos de sistemas de regulación.

Modelo GCE	251 E4R 251 E6R 251 E8R	251 E4 251 E6 251 E8	252G4 252G6 252G8	252 E4 252 E6 252 E8	253G4 253G6 253G8	253 E4 253 E6 253 E8	254G4 254G6 254G8	254 E4 254 E6 254 E8	311F4 311F6 311F8	312F4 312F6 312F8	313F4 313F6 313F8	314F4 314F6 314F8					
Motoventilador	1 x 250		2 x 250		3 x 250		4 x 250		1 x 315		2 x 315		3 x 315		4 x 315		
Frecuencia	Hz	50	60	50	60	50	60	50	60	50	60	50	60	50	60	50	60
Consumo	A	0,68	-	1,36	-	2,04	-	2,72	-	0,52	0,66	1,04	1,32	1,56	1,98	2,08	2,64
motoventilador	W	95	-	190	-	285	-	380	-	110	148	220	296	330	444	440	592
RPM		1300	1550	1300	1550	1300	1550	1300	1550	1350	1490	1350	1490	1350	1490	1350	1490

Modelo GCE	351 E4 351 E6 351 E8	351A4 351A6 351A8	352 E4 352 E6 352 E8	352 A4 352 A6 352 A8	353 F4 353 F6 353 F8	353A4 353A6 353A8	354 F4 354 F6 354 F8	354 A4 354 A6 354 A8	355 A4 355 A6 355 A8		
Motoventilador	1 x 350		2 x 350		3 x 350		4 x 350		5 x 350		
Frecuencia	Hz	50	60	50	60	50	60	50	60	50	60
Consumo	A	0,96	1,08	1,92	2,16	2,88	3,24	3,84	4,32	4,80	5,40
motoventilador	W	185	250	370	500	555	750	740	1000	925	1250
RPM		1420	1660	1420	1660	1420	1660	1420	1660	1420	1660

### Esquema de conexión motoventiladores ø 250 mm

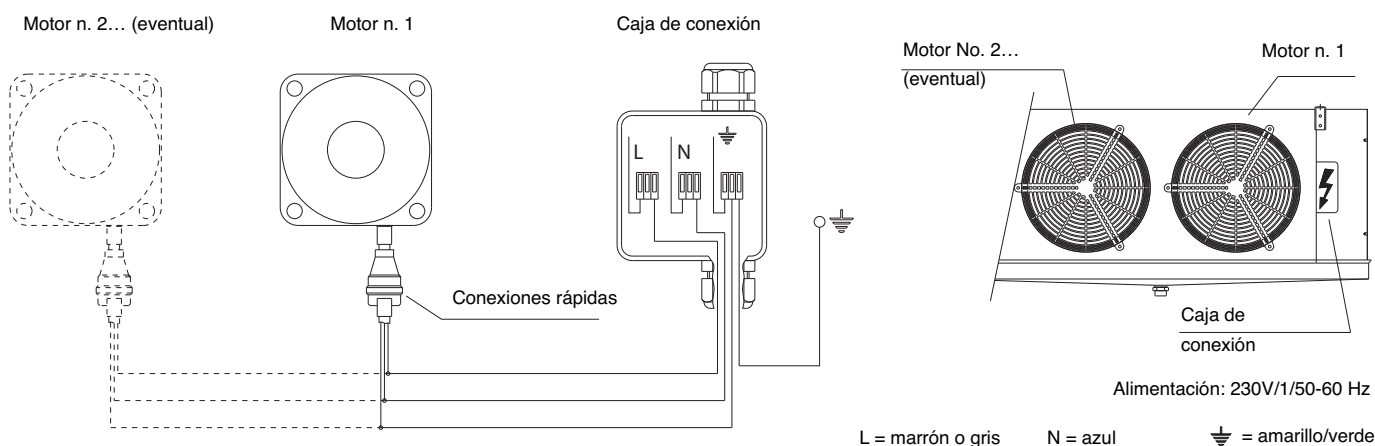

### Esquema de conexión motoventiladores ø 315 - 350 mm

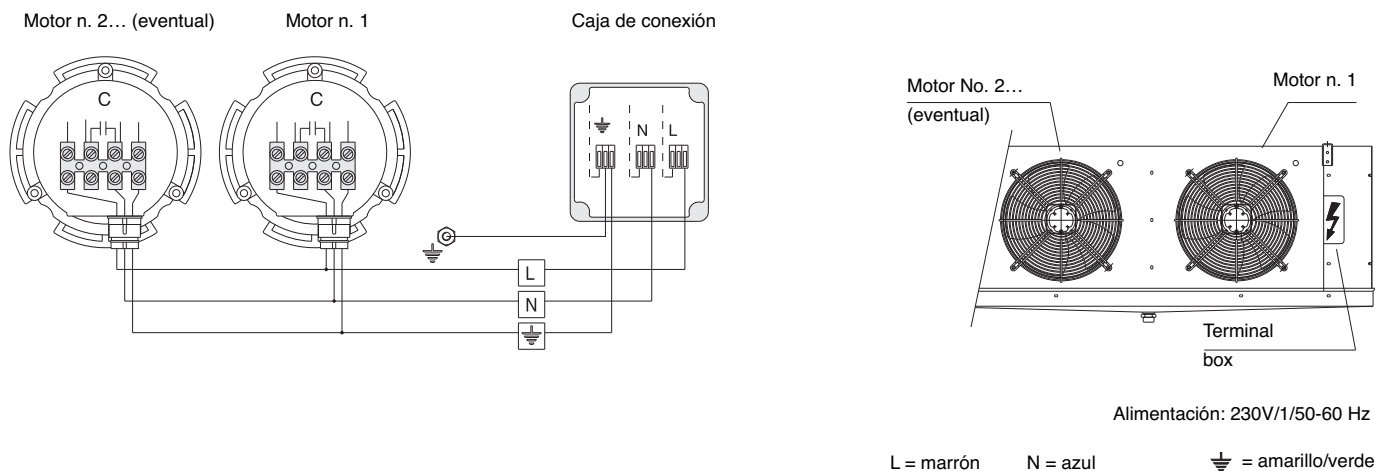

## Sugerencias para un correcto acceso al aparato

### Acceso

1. Desmontar el tubo desagüe.
2. Desmontar los tornillos de fijación "A" de la bandeja exterior a la bandeja desagüe interna.
3. Destornillar los tornillos autoroscantes "B" sin sacarlos del todo y desmontar la tapa lateral.

### Montar nuevamente la unidad

1. Colocar la tapa lateral y fijarla mediante el tornillo "B".
2. Colocar la bandeja exterior en posición, teniendo cuidado que la tapa lateral esté en el interior de la bandeja. Después fijarla con los tornillos tipo "A".
3. Volver a montar el tubo desagüe.

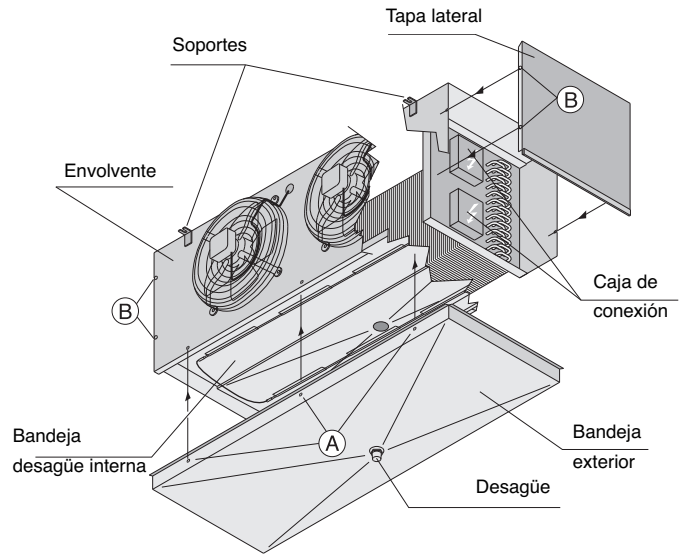

## Esquema de conexión y potencia de las resistencias eléctricas

### Atención

Es obligatorio montar sistemas de protección térmica en las líneas de alimentación. Comprobar periódicamente la funcionalidad de todas las resistencias para evitar acumulaciones peligrosas de hielo en las unidades. El fabricante no responde en ningún caso de problemas causados por funcionamientos defectuosos no detectados.

### Modelo con helice $\varnothing$ 250 mm

#### CONEXIÓN 400V/3/50 Hz CONECTADO DE FÁBRICA

GCE 251ExR

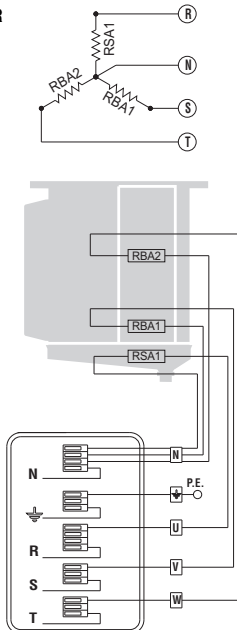

GCE 252Gx  
253Gx  
254Gx

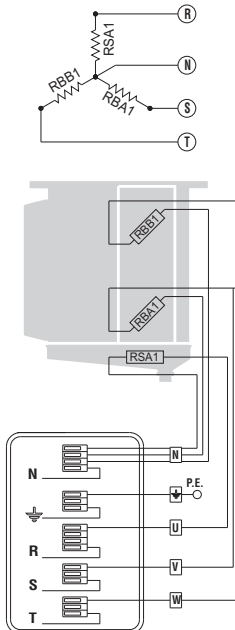

GCE 251Ex  
252Ex  
253Ex  
254Ex

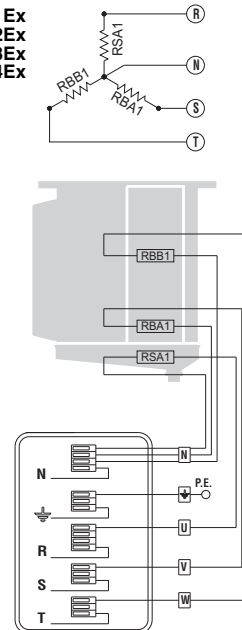

### RBA (1-2)

Resistencia de alta potencia en la batería.

### RBB1

Resistencia de baja potencia en la batería.

### RSA1

Resistencia de alta potencia en la bandeja desagüe interna.

Modelo GCE "ED" $\varnothing$ 250	251E4R	251E4	252G4	252E4	253G4	253E4	254G4	254E4
	251E6R	251E6	252G6	252E6	253G6	253E6	254G6	254E6
Filas	4 RR	4 RR	3 RR	4 RR	3 RR	4 RR	3 RR	4 RR
Potencia total (W)	750	1125	2250	2250	3325	3325	4375	4375



## Esquema de conexión y potencia de las resistencias eléctricas

### Atención

Es obligatorio montar sistemas de protección térmica en las líneas de alimentación. Comprobar periódicamente la funcionalidad de todas las resistencias para evitar acumulaciones peligrosas de hielo en las unidades. El fabricante no responde en ningún caso de problemas causados por funcionamiento defectuosos no detectados.

### Modelo con helice ø 250 mm

CONEXIÓN 230V/1/50 Hz POSIBLE VER SISTEMA

GCE 251ExR

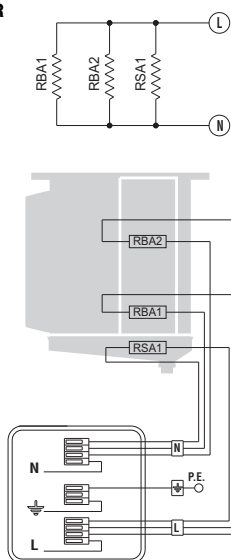

GCE 252Gx  
253Gx  
254Gx

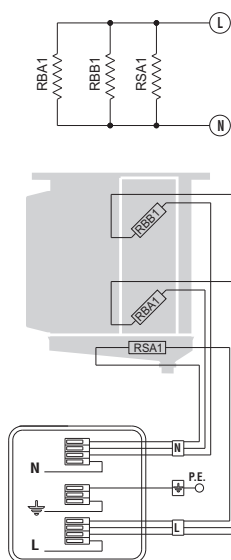

GCE 251Ex  
252Ex  
253Ex  
254Ex

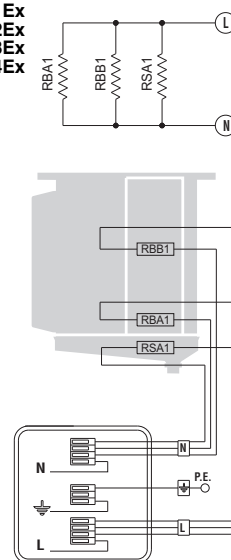

#### RBA (1-2)

Resistencia de alta potencia en la batería.

#### RBB1

Resistencia de baja potencia en la batería.

#### RSA1

Resistencia de alta potencia en la bandeja desagüe interna.

Modelo GCE "ED" ø 250	251E4R 251E6R 251E8R	251E4 251E6 251E8	252G4 252G6 252G8	252E4 252E6 252E8	253G4 253G6 253G8	253E4 253E6 253E8	254G4 254G6 254G8	254E4 254E6 254E8
Filas	4 RR	4 RR	3 RR	4 RR	3 RR	4 RR	3 RR	4 RR
Potencia total (W)	750	1125	2250	2250	3325	3325	4375	4375

### Modelo con helice ø 315 mm

400V/3/50 Hz CONEXIÓN  
(conectado de fábrica)

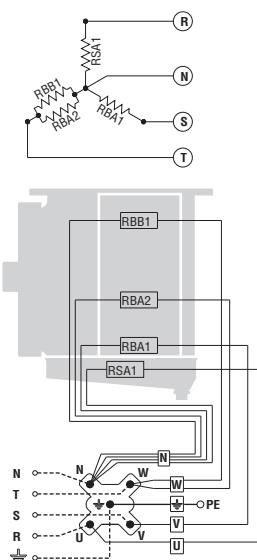

230V/1/50 Hz CONEXIÓN  
(posible ver sistema)

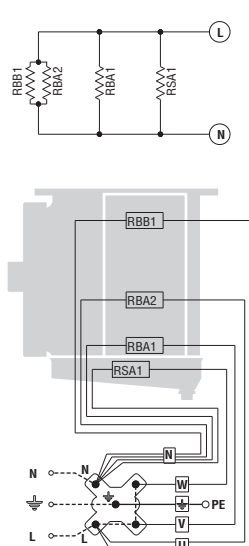

**RBA (1-2)** Resistencia de alta potencia en la batería.

**RBB1** Resistencia de baja potencia en la batería.

**RSA1** Resistencia de alta potencia en la bandeja desagüe interna.

Modelo GCE "ED" ø 315	311F4 311F6 311F8	312F4 312F6 312F8	313F4 313F6 313F8	314F4 314F6 314F8
Filas	5 RR	5 RR	5RR	5 RR
Potencia total (W)	1750	3150	4900	6300

# Esquema de conexión y potencia de las resistencias eléctricas

**Atención**  
 Es obligatorio montar sistemas de protección térmica en las líneas de alimentación. Comprobar periódicamente la funcionalidad de todas las resistencias para evitar acumulaciones peligrosas de hielo en las unidades. El fabricante no responde en ningún caso de problemas causados por funcionamiento defectuosos no detectados.

## Model with ø 350 mm fan motor 4-5 RR standard

400V/3/50 Hz CONEXIÓN  
(conectado de fábrica)

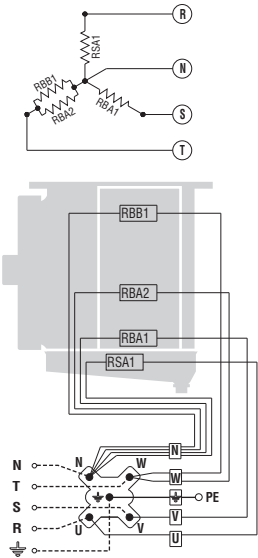

230V/1/50 Hz CONEXIÓN  
(posible ver sistema)

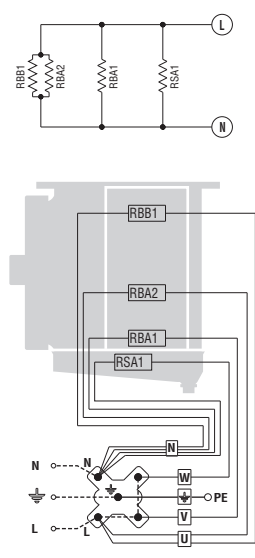

**RBA (1-2)** Resistencia de alta potencia en la batería.  
**RBB1** Resistencia de baja potencia en la batería.  
**RSA1** Resistencia de alta potencia en la bandeja desagüe interna.

Modelo GCE "ED" ø 350	351 E4	352 E4	353 F4	354 F4
	351 E6	352 E6	353 F6	354 F6
	351 E8	352 E8	353 F8	354 F8
Filas	4 RR	4 RR	5 RR	5 RR
Potencia total (W)	1750	3150	4900	6300

## Modelo con helice ø 350 mm 4-5 RR potenciado

400V/3/50 Hz CONEXIÓN  
(conectado de fábrica)

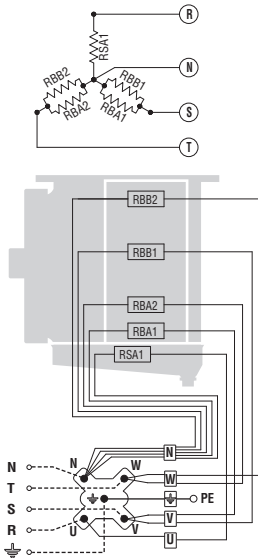

230V/1/50 Hz CONEXIÓN  
(posible ver sistema)

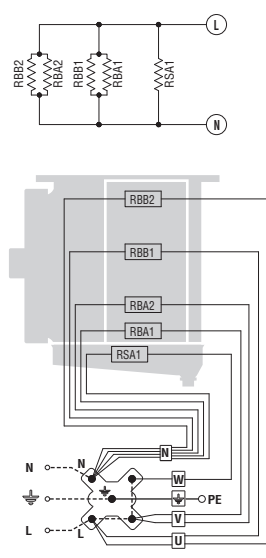

**RBA (1-2)** Resistencia de alta potencia en la batería.  
**RBB (1-2)** Resistencia de baja potencia en la batería.  
**RSA1** Resistencia de alta potencia en la bandeja desagüe interna.

Modelo GCE "ED" ø 350	351 E4	352 E4	353 F4	354 F4
	351 E6	352 E6	353 F6	354 F6
	351 E8	352 E8	353 F8	354 F8
Filas	4 RR	4 RR	5 RR	5 RR
Potencia total (W)	2000	3600	5600	7200

## Esquema de conexión y potencia de las resistencias eléctricas

### Atención

Es obligatorio montar sistemas de protección térmica en las líneas de alimentación. Comprobar periódicamente la funcionalidad de todas las resistencias para evitar acumulaciones peligrosas de hielo en las unidades. El fabricante no responde en ningún caso de problemas causados por fucionamientos defectuosos no detectados.

### Modelo con helice ø 350 mm

### 6 RR standard

400V/3/50 Hz CONEXIÓN  
(conectado de fábrica)

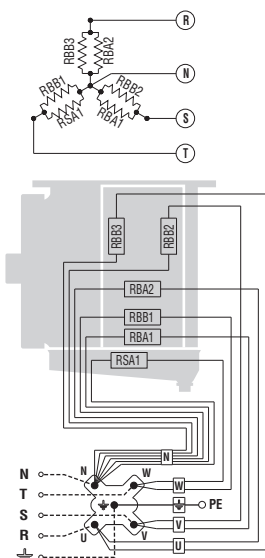

230V/3/50 Hz CONEXIÓN  
(posible ver sistema)

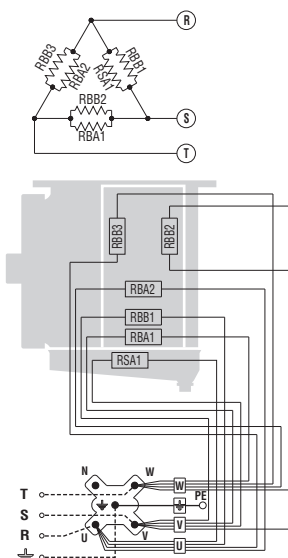

230V/1/50 Hz CONEXIÓN  
(posible ver sistema)

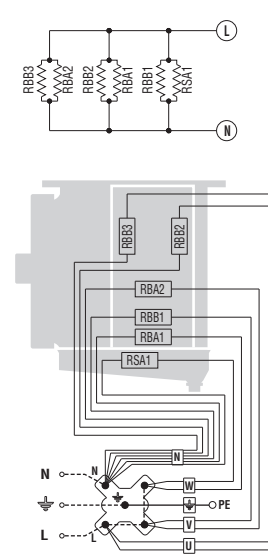

- RBA (1-2)** High power electric heater in coil.
- RBB (1-2-3)** Low power electric heaters in coil.
- RSA1** High power electric heater on inner drip tray.

Model GCE "ED" ø 350	351 A4 351 A6 351 A8	352 A4 352 A6 352 A8	353 A4 353 A6 353 A8	354 A4 354 A6 354 A8	355 A4 355 A6 355 A8
Rows	6 RR	6 RR	6 RR	6 RR	6 RR
Total power (W)	2250	4050	6300	8100	9900

### Modelo con helice ø 350 mm

### 6 RR potenciado

400V/3/50 Hz CONEXIÓN  
(conectado de fábrica)

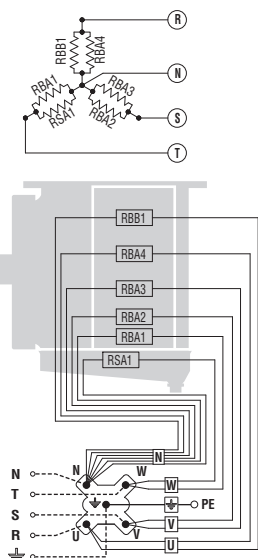

230V/1/50 Hz CONEXIÓN  
(posible ver sistema)

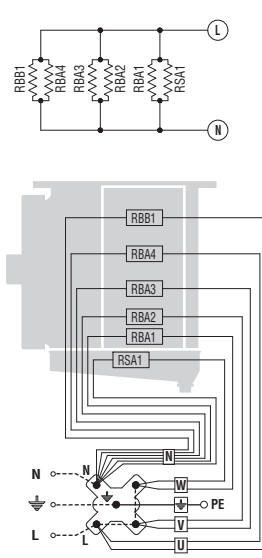

- RBA (1-2-3-4)** Resistencia de alta potencia en la batería.
- RBB1** Resistencia de baja potencia en la batería.
- RSA1** Resistencia de alta potencia en la bandeja desagüe interna.

Modelo GCE "ED" ø 350	351 A4 351 A6 351 A8	352 A4 352 A6 352 A8	353 A4 353 A6 353 A8	354 A4 354 A6 354 A8	355 A4 355 A6 355 A8
Filas	6 RR	6 RR	6 RR	6 RR	6 RR
Potencia total (W)	2750	4950	7700	9900	12100

## Attention

1. Conserver ce manuel technique pendant toute la période de vie du modèle.
2. Lire avec attention le manuel avant l'installation et avant toute intervention sur le modèle.
3. Employer le modèle exclusivement dans le but pour lequel il a été projeté; l'utilisation impropre libère le constructeur de toute responsabilité.

## Inspection - Transport

1. A réception du modèle, contrôler immédiatement son état; constater de suite à la compagnie de transport tout dommage éventuel.
2. Pendant le transport, éviter d'exercer des pressions exagérées sur l'emballage, qui doit toujours être maintenu dans la position indiquée sur celui-ci.
3. Déballer le modèle le plus près possible du lieu d'installation. Après déballage, faire attention à ne pas heurter les composants.
4. Pendant l'installation et la manutention du modèle, utiliser des gants de protection spéciaux pour éviter toute blessure avec les parties coupantes (par ex. ailettes) du modèle.

## Conditions à vérifier pour une mise en marche correcte

1. Vérifier la charge admissible des structures de support par rapport au poids de l'appareil.
2. Vérifier que le modèle soit installé horizontalement.
3. Pour une circulation correcte de l'air en aspiration et en refoulement, il faut disposer d'un volume adapté (30% environ du volume interne de la chambre).

**Des conditions d'installation ou de fonctionnement particulières telles que chambres froides basses, poutrages plafonniers, stockages excessifs, empêchements au jet et/ou à l'aspiration de l'air, formation impropre de givre due à une introduction excessive d'humidité dans la chambre froide, peuvent influencer de façon négative les prestations déclarées et créer des défauts dans les modèles.**

**Les modèles standard peuvent être adaptés à fonctionner dans des tunnels ou chambres de surgélation rapide.**

4. Les modèles sont équipés de motoventilateurs axiaux, par conséquent non adaptés à une canalisation ou à supporter des pressions statiques additionnelles.
5. Vérifier que les conditions de fonctionnement (températures et pressions) soient conformes à celles du projet.
6. Effectuer les branchements avec beaucoup de soin afin que les éventuels capillaires ne se déforment pas et que la position du distributeur ne change pas.
7. Dans le cas d'installation de plusieurs modèles très près l'un de l'autre, éviter les dégivrages alternés.
8. Installer les siphons sur les goulots de déchargement condensat et en vérifier l'efficacité à toutes les températures d'utilisation.
9. Éviter l'installation à proximité des portes des chambres froides.
10. Positionner la sonde de température pour la fin de dégivrage dans les zones les plus froides des échangeurs, c'est à dire dans les zones qui risquent de givrer le plus (à la fin du cycle, il ne doit pas rester de glace sur les modèles). La position de ce dispositif ne peut être définie a priori, vu qu'elle change en fonction du type de chambre et du type d'installation.
11. Vérifier que la ligne électrique d'alimentation soit adaptée aux caractéristiques électriques de l'appareil.
12. S'assurer que tous les branchements électriques soient en accord avec les normes en vigueur.
13. Les unités sont prédisposées pour le branchement électrique à terre. L'installateur et/ou le responsable de l'unité doivent garantir la présence d'un branchement à terre, efficace comme

protection contre les contacts électriques indirects. Sur demande, les modèles peuvent être fournis avec échangeurs, dégivrages et moto-ventilateurs différents du standard. Les résistances électriques utilisées pour l'éventuel dégivrage se trouvent dans la boîte de dérivation en matériel thermo-plastique (protection contre le contact électrique direct de classe II) ayant degré de protection IP 54.





14. Après installation, enlever la pellicule de protection qui recouvre le modèle.
15. L'accessibilité au modèle, pour tout type d'intervention, doit être réservée au personnel qualifié à la gestion de l'installation, selon les normes en vigueur.

## Entretien général

1. Verificare periodicamente i fissaggi, le connessioni elettriche e i collegamenti all'impianto frigorifero.
2. Provvedere alla pulizia periodica dell'apparecchio, per evitare accumuli di sostanze nocive. Si consiglia l'utilizzo di normale acqua saponata, evitando solventi, agenti aggressivi, abrasivi o a base di ammoniaca.
3. In caso di sostituzioni di resistenze elettriche prestare particolare attenzione nelle fasi di installazione per evitare danni alle vulcanizzazioni; ripristinare correttamente i collegamenti e i sistemi di fissaggio esistenti per evitare movimenti delle stesse durante il funzionamento.

**Ces opérations devront être effectuées par du personnel expert et qualifié.**

## Dangers

1.  Danger d'électrocution. Le modèle est pourvu d'électroventilateurs et de résistances électriques de dégivrage. La tension d'alimentation est de 400V AC. Utiliser des systèmes de sécurité électrique prévus par les normes en vigueur.
2.  Danger de brûlures. Les résistances électriques de dégivrage peuvent atteindre des températures superficielles de 350°C.
3.  Danger de coupures. L'échangeur de chaleur est constitué d'ailettes à bords coupants et la carrosserie de parties en tôle.
4.  Danger de parties en mouvement. Le modèle est pourvu d'électroventilateurs dotés de grille de protection externe.
5.  Danger d'écrasement. Le modèle peut peser plus de 100 kg.

## Normes de référence

- DIRECTIVE MACHINES 2006/42/EC
- DIRECTIVE BASSE TENSION 2014/35/UE
- DIRECTIVE COMP. ELECTROMAGNETIQUE 2014/30/UE
- DIRECTIVE PED 2014/68/UE
- DIRECTIVE ERP 2009/125/EC

### Attention

Avant d'effectuer toute intervention d'entretien, vérifier que l'alimentation électrique soit déconnectée de la source principale: les parties électriques pourraient être reliées à des contrôles automatiques.

## Instructions pour une installation correcte

### Distance latérale minimum de la paroi côté résistances - Distance minimum de la paroi côté aspiration

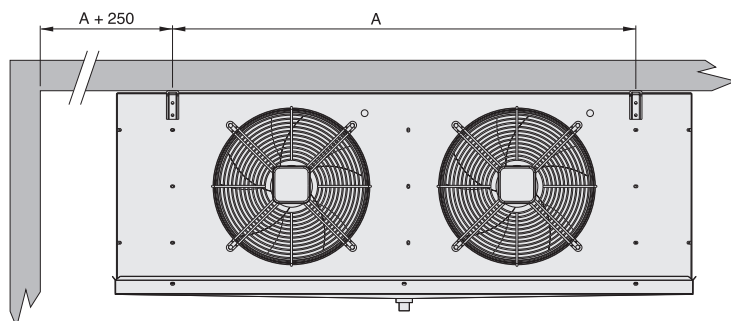

Afin de pouvoir enlever/installer latéralement les résistances, lors de l'installation, respecter la cote min. A+250 mm.

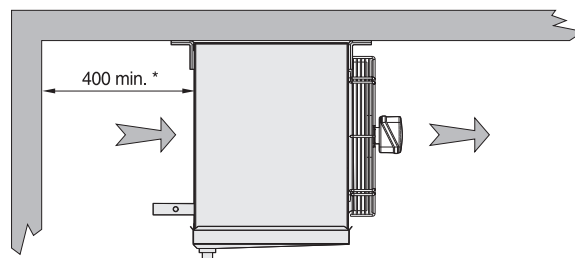

Pour un bon fonctionnement du moteur, lors de l'installation, respecter la cote min. de 400 mm.

## Caractéristiques constructives et dimensionnelles

### Modèle avec hélice ø 250 mm

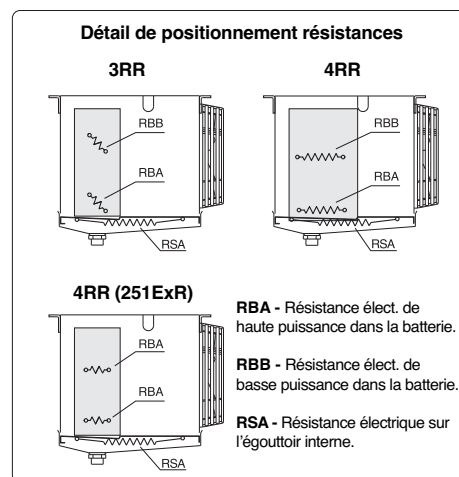
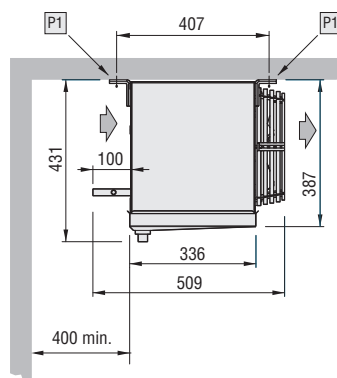
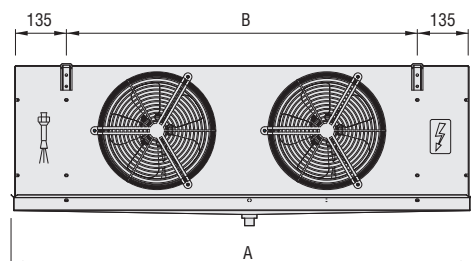

Modèle	GCE	251 E4R	251 E4	252 G4	252 E4	253 G4	253 E4	254 G4	254 E4
		251 E6R	251 E6	252 G6	252 E6	253 G6	253 E6	254 G6	254 E6
		251 E8R	251 E8	252 G8	252 E8	253 G8	253 E8	254 G8	254 E8
Motoventilateurs	n° x Ø mm	1x250	1x250	2x250	2x250	3x250	3x250	4x250	4x250
Dimensions	A	674	774	1224	1224	1674	1674	2124	2124
	B	380	480	930	930	1380	1380	1830	1830
Raccords internes batterie	In tube (mm)	12	12	12	12	12	12	12	16
	Out tube (mm)	12	12	22	22	22	22	22 (G4: 28)	28
Raccord d'écoulement	Ø (GAS)	1"	1"	1"	1"	1"	1"	1"	1"
Poids net	kg	13	14,5	21,5	24	30	33	38	41,5

Utiliser valve thermostatique avec égalisateur de pression externe

# Caractéristiques constructives et dimensionnelles

## Modèle avec hélice ø 315 mm

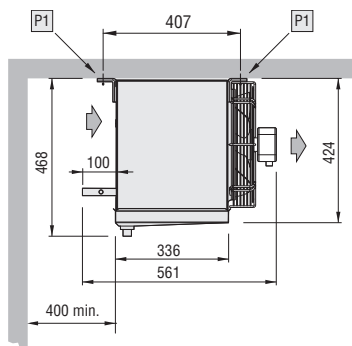
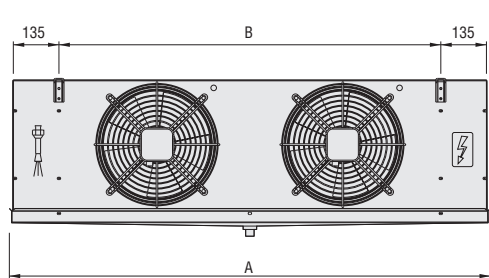

### Détail de positionnement résistances

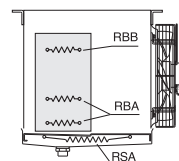

RBA - Résistance élect. de haute puissance dans la batterie.  
RBB - Résistance élect. de basse puissance dans la batterie.  
RSA - Résistance électrique sur l'égouttoir interne.

P1

### Détail de fixage

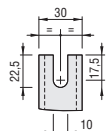

Modèle	GCE	311F4		312F4		313F4		314F4	
		311F6	311F8	312F6	312F8	313F6	313F8	314F6	314F8
Motoventilateurs	n° x Ø mm	1x315		2x315		3x315		4x315	
Dimensions	A	874		1424		1974		2524	
	B	580		1130		1680		2230	
Raccords internes batterie	In tube (mm)	12		12		16		16 (F4: 22)	
	Out tube (mm)	22		28		28		28 (F8: 35)	
Raccord d'écoulement	Ø (GAS)	1"		1"		1"		1"	
Poids net	kg	20		34		47,5		61	

Utiliser valve thermostatique avec égalisateur de pression externe

## Modèle avec hélice ø 350 mm

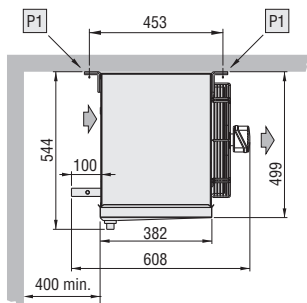
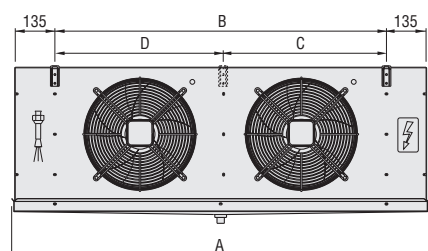

P1

### Détail de fixage

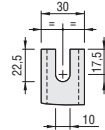

### Détail de positionnement résistances

35°E4 ED 35°F4 ED  
35°E6 ED 35°F6 ED  
35°E8 ED 35°F8 ED

35°E4 EDP 35°F4 EDP  
35°E6 EDP 35°F6 EDP  
35°E8 EDP 35°F8 EDP

35°A4 ED 35°A6 ED 35°A8 ED

35°A4 EDP 35°A6 EDP 35°A8 EDP

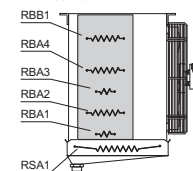
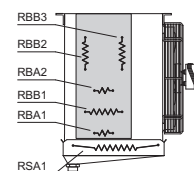
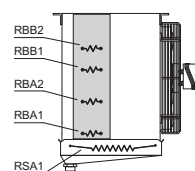
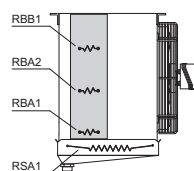

RBA - Résistance élect. de haute puissance dans la batterie.  
RBB - Résistance élect. de basse puissance dans la batterie.  
RSA - Résistance électrique sur l'égouttoir interne.

Modello	GCE	351 E4	351A4	352 E4	352 A4	353 F4	353A4	354 F4	354 A4	355 A4
		351 E6	351A6	352 E6	352 A6	353 F6	353A6	354 F6	354 A6	355 A6
		351 E8	351A8	352 E8	352 A8	353 F8	353A8	354 F8	354 A8	355 A8
Motoventilatori	n° x Ø	1x350	1x350	2x350	2x350	3x350	3x350	4x350	4x350	5x350
Dimensioni	A mm	875	875	1425	1425	1975	1975	2525	2525	3075
	B mm	580	580	1130	1130	1680	1680	2230	2230	2780
	C mm	-	-	-	-	-	-	1115	1115	1665
	D mm	-	-	-	-	-	-	1115	1115	1115
Raccords internes batterie	In tube (mm)	12	12	16	16	16 (F4: 22)	22	22	28	28
	Out tube (mm)	22	22	28	28	28 (F8: 35)	35	35 (F8: 42)	42	42
Attacco scarico	Ø (GAS)	1	1	1	1	1	1	1	1	1
Peso netto	kg	22	26,5	41	48	58	63	77	83,5	103

Utiliser valve thermostatique avec égalisateur de pression externe

## Schéma de connexion motoventilateurs

### Attention

Les moteurs sont dotés de thermocontacts de protection internes à réenclenchement automatique. Avant d'utiliser des systèmes de réglage du nombre de tours des moteurs, vérifier la compatibilité avec ces mêmes moteurs; des systèmes non compatibles peuvent générer des nuisances sonores ou des dommages aux moteurs mêmes; le fabricant n'assume aucune responsabilité sur les prestations des modèles équipés avec systèmes de réglage.

Modèle GCE	251 E4R	251 E4	252G4	252 E4	253G4	253 E4	254G4	254 E4	311F4	312F4	313F4	314F4					
	251 E6R	251 E6	252G6	252 E6	253G6	253 E6	254G6	254 E6	311F6	312F6	313F6	314F6					
	251 E8R	251 E8	252G8	252 E8	253G8	253 E8	254G8	254 E8	311F8	312F8	313F8	314F8					
Motoventilateurs	1 x 250		2 x 250		3 x 250		4 x 250		1 x 315		2 x 315		3 x 315		4 x 315		
Fréquence	Hz	50	60	50	60	50	60	50	60	50	60	50	60	50	60	50	60
Absorption	A	0,68	-	1,36	-	2,04	-	2,72	-	0,52	0,66	1,04	1,32	1,56	1,98	2,08	2,64
W	W	95	-	190	-	285	-	380	-	110	148	220	296	330	444	440	592
RPM		1300	1550	1300	1550	1300	1550	1300	1550	1350	1490	1350	1490	1350	1490	1350	1490

Modèle GCE	351 E4	351A4	352 E4	352 A4	353 F4	353A4	354 F4	354 A4	355 A4		
	351 E6	351A6	352 E6	352 A6	353 F6	353A6	354 F6	354 A6	355 A6		
	351 E8	351A8	352 E8	352 A8	353 F8	353A8	354 F8	354 A8	355 A8		
Motoventilateurs	1 x 350		2 x 350		3 x 350		4 x 350		5 x 350		
Fréquence	Hz	50	60	50	60	50	60	50	60	50	60
Absorption	A	0,96	1,08	1,92	2,16	2,88	3,24	3,84	4,32	4,80	5,40
W	W	185	250	370	500	555	750	740	1000	925	1250
RPM		1420	1660	1420	1660	1420	1660	1420	1660	1420	1660

### Schéma de connexion motoventilateurs ø 250 mm

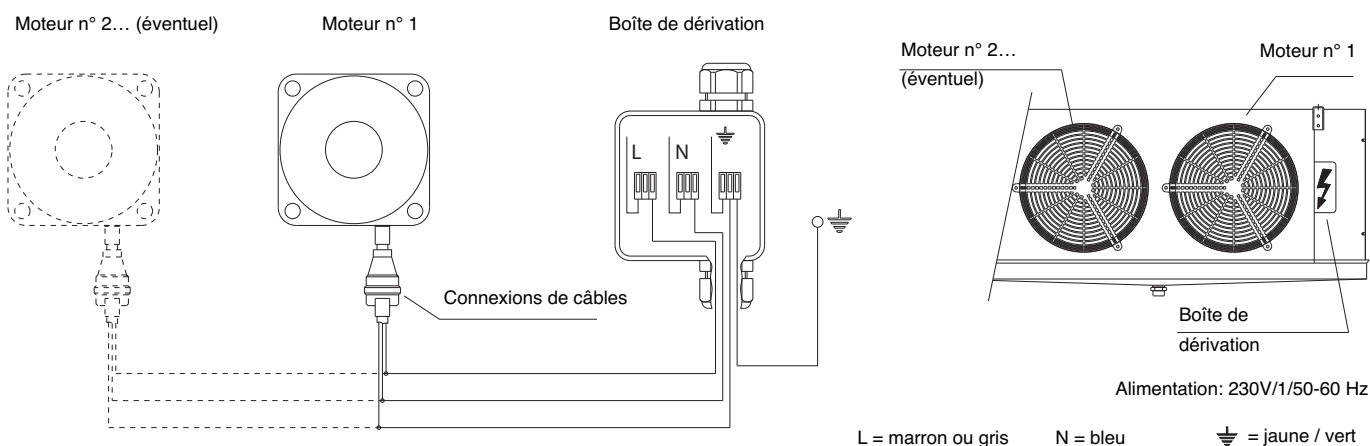

### Schéma de connexion motoventilateurs ø 315 - 350 mm

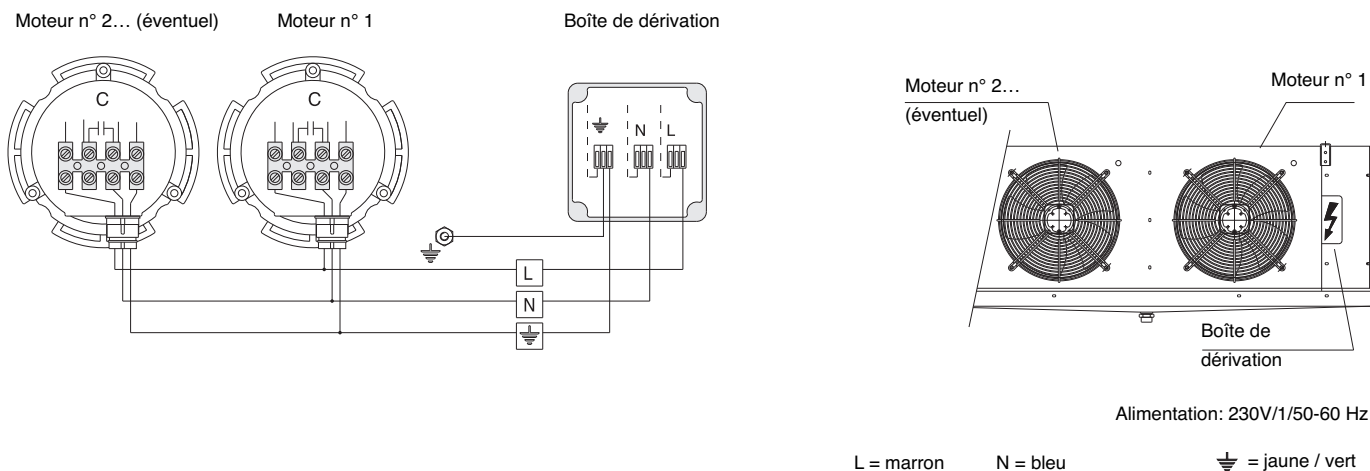

# Instructions pour accéder à l'appareil

## Accès

1. Démontez le tube d'écoulement.
2. Desserrer les vis "A" qui fixent le bac à l'égouttoir interne.
3. Desserrer les vis à tôle "B" sans les enlever complètement puis extraire le couvercle latéral.

## Remontage

1. Replacer le couvercle latéral et le fixer avec les vis "B".
2. Replacer le bac en faisant attention que les couvercles latéraux soient internes à celui-ci, puis le fixer avec les vis "A".
3. Remonter le tube d'écoulement.

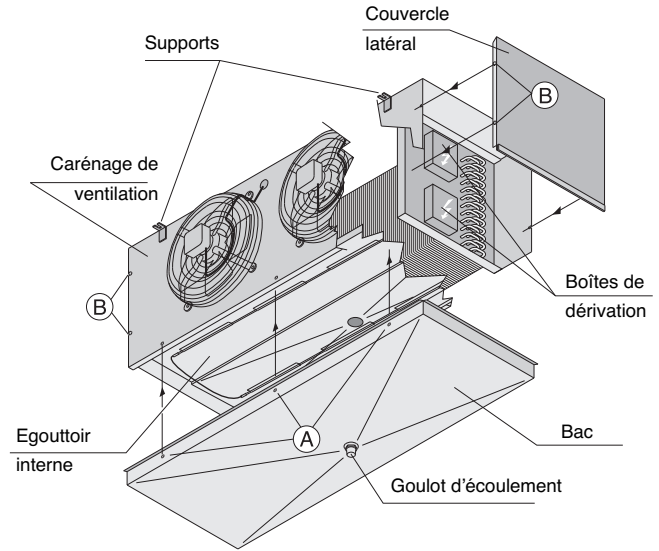

# Schéma de connexion et puissances des résistances électriques

**Attention**  
Il est obligatoire d'appliquer d'opportuns systèmes de protection thermique sur les lignes d'alimentation. Vérifier périodiquement les fonctionnalités de toutes les résistances pour éviter l'accumulation dommageable de glace sur les modèles. Le fabricant ne répond en aucune manière des défectuosités générées par des mauvais fonctionnements non relevés.

## Modelo con helice ø 250 mm

### CONNEXION 400V/3/50 Hz PREDISPOSEE

GCE 251ExR

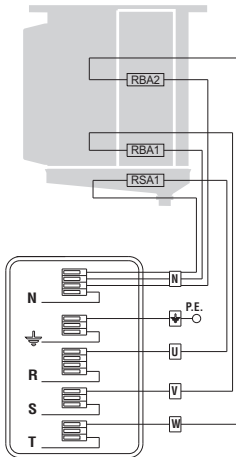
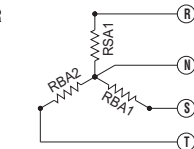

GCE 252Gx  
253Gx  
254Gx

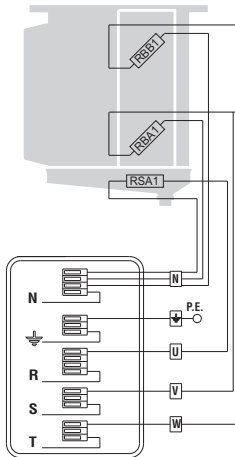
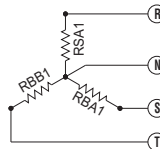

GCE 251Ex  
252Ex  
253Ex  
254Ex

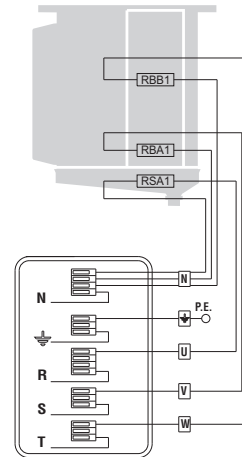
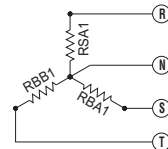

**RBA (1-2)**

Résistances de haute puissance dans la batterie.

**RBB1**

Résistance de basse puissance dans la batterie.

**RSA1**

Résistances de haute puissance sur l'égouttoir interne.

Modèle GCE "ED" ø 250	251E4R	251E4	252G4	252E4	253G4	253E4	254G4	254E4
	251E6R	251E6	252G6	252E6	253G6	253E6	254G6	254E6
	251E8R	251E8	252G8	252E8	253G8	253E8	254G8	254E8
Nappes	4 RR	4 RR	3 RR	4 RR	3 RR	4 RR	3 RR	4 RR
Puissance totale (W)	750	1125	2250	2250	3325	3325	4375	4375



## Schéma de connexion et puissances des résistances électriques

### Attention

Il est obligatoire d'appliquer d'opportuns systèmes de protection thermique sur les lignes d'alimentation. Vérifier périodiquement les fonctionnalités de toutes les résistances pour éviter l'accumulation dommageable de glace sur les modèles. Le fabricant ne répond en aucune manière des défauts générés par des mauvais fonctionnements non relevés.

### Modelo con helice ø 250 mm

#### CONNEXION 230V/1/50 Hz A PREDISPOSER

##### GCE 251ExR

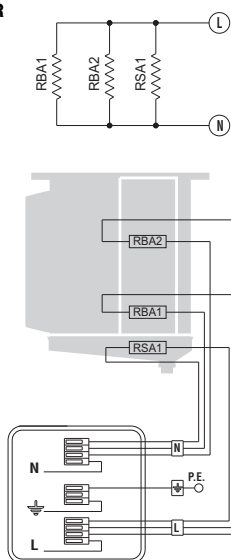

##### GCE 252Gx 253Gx 254Gx

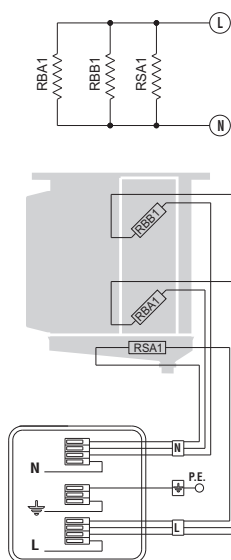

##### GCE 251Ex 252Ex 253Ex 254Ex

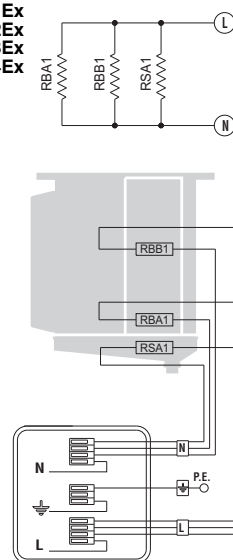

#### RBA (1-2)

Résistances de haute puissance dans la batterie.

#### RBB1

Résistance de basse puissance dans la batterie.

#### RSA1

Résistances de haute puissance sur l'égouttoir interne.

Modèle GCE "ED" ø 250	251E4R 251E6R 251E8R	251E4 251E6 251E8	252G4 252G6 252G8	252E4 252E6 252E8	253G4 253G6 253G8	253E4 253E6 253E8	254G4 254G6 254G8	254E4 254E6 254E8
Nappes	4 RR	4 RR	3 RR	4 RR	3 RR	4 RR	3 RR	4 RR
Puissance totale (W)	750	1125	2250	2250	3325	3325	4375	4375

### Modèle avec hélice ø 315 mm

#### CONNEXION 400V/3/50 Hz (prédisposée)

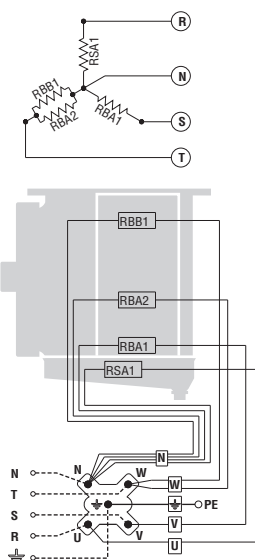

#### CONNEXION 230V/1/50 Hz (à prédisposer)

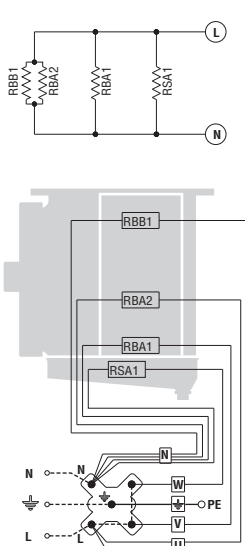

**RBA (1-2)** Résistances de haute puissance dans la batterie.

**RBB1** Résistance de basse puissance dans la batterie.

**RSA1** Résistances de haute puissance sur l'égouttoir interne.

Modèle GCE "ED" ø 315	311F4 311F6 311F8	312F4 312F6 312F8	313F4 313F6 313F8	314F4 314F6 314F8
Nappes	5 RR	5 RR	5RR	5 RR
Puissance totale (W)	1750	3150	4900	6300

# Schéma de connexion et puissances des résistances électriques

**Attention**  
 Il est obligatoire d'appliquer d'opportuns systèmes de protection thermique sur les lignes d'alimentation. Vérifier périodiquement les fonctionnalités de toutes les résistances pour éviter l'accumulation dommageable de glace sur les modèles. Le fabricant ne répond en aucune manière des défauts générés par des mauvais fonctionnements non relevés.

## Modèle avec hélice ø 315 mm 4-5 RR standard

CONNEXION 400V/3/50 Hz  
(prédisposée)

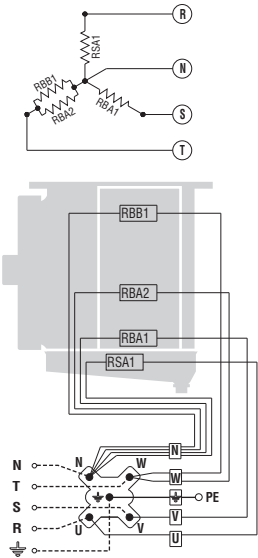

CONNEXION 230V/1/50 Hz  
(à prédisposer)

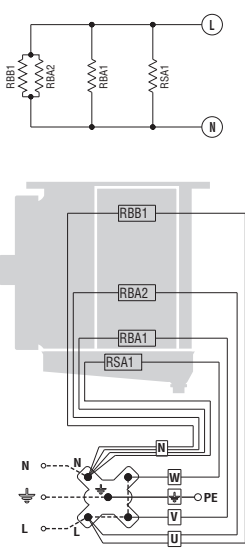

**RBA (1-2)** Résistances de haute puissance dans la batterie.  
**RBB1** Résistance de basse puissance dans la batterie.  
**RSA1** Résistances de haute puissance sur l'égouttoir interne.

Modèle GCE "ED" ø 350	351 E4	352 E4	353 F4	354 F4
	351 E6	352 E6	353 F6	354 F6
	351 E8	352 E8	353 F8	354 F8
Nappes	4 RR	4 RR	5 RR	5 RR
Puissance totale (W)	1750	3150	4900	6300

## Modèle avec hélice ø 350 mm 4-5 RR majoré

CONNEXION 400V/3/50 Hz  
(prédisposée)

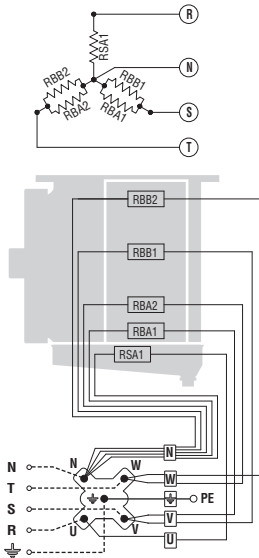

CONNEXION 230V/1/50 Hz  
(à prédisposer)

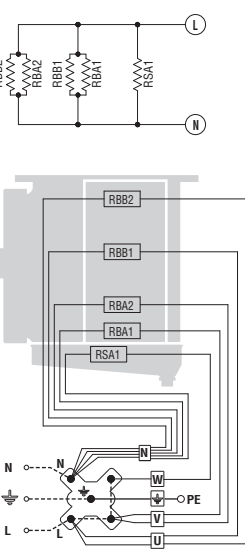

**RBA (1-2)** Résistance de haute puissance dans la batterie.  
**RBB (1-2)** Résistance de basse puissance dans la batterie.  
**RSA1** Résistance de haute puissance sur l'égouttoir interne.

Modèle GCE "ED" ø 350	351 E4	352 E4	353 F4	354 F4
	351 E6	352 E6	353 F6	354 F6
	351 E8	352 E8	353 F8	354 F8
Nappes	4 RR	4 RR	5 RR	5 RR
Puissance totale (W)	2000	3600	5600	7200

## Schéma de connexion et puissances des résistances électriques

### Attention

Il est obligatoire d'appliquer d'opportuns systèmes de protection thermique sur les lignes d'alimentation. Vérifier périodiquement les fonctionnalités de toutes les résistances pour éviter l'accumulation dommageable de glace sur les modèles. Le fabricant ne répond en aucune manière des défauts générés par des mauvais fonctionnements non relevés.

### Modèle avec hélice ø 350 mm

### 6RR standard

CONNEXION 400V/3/50 Hz  
(prédisposée)

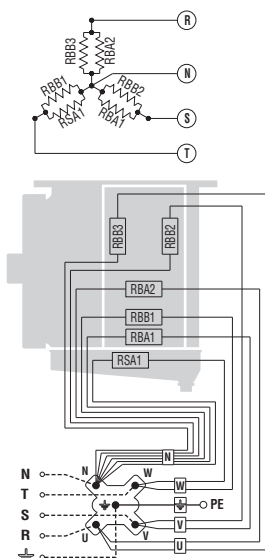

CONNEXION 230V/3/50 Hz  
(à prédisposer)

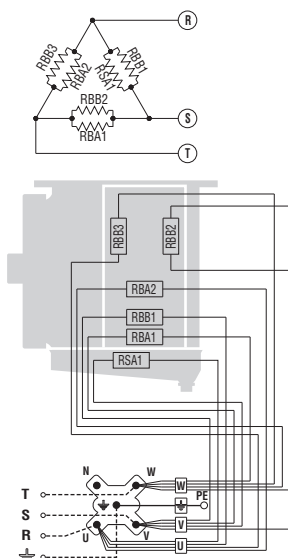

CONNEXION 230V/1/50 Hz  
(à prédisposer)

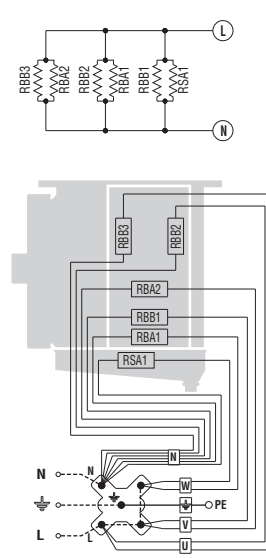

- RBA (1-2) Résistance de haute puissance dans la batterie.
- RBB (1-2-3) Résistance de basse puissance dans la batterie.
- RSA1 Résistance de haute puissance sur l'égouttoir interne.

Modèle GCE "ED" ø 350	351 A4	352 A4	353 A4	354 A4	355 A4
	351 A6	352 A6	353 A6	354 A6	355 A6
	351 A8	352 A8	353 A8	354 A8	355 A8
Nappes	6 RR	6 RR	6 RR	6 RR	6 RR
Puissance totale (W)	2250	4050	6300	8100	9900

### Modèle avec hélice ø 350 mm

### 6RR majoré

CONNEXION 400V/3/50 Hz  
(prédisposée)

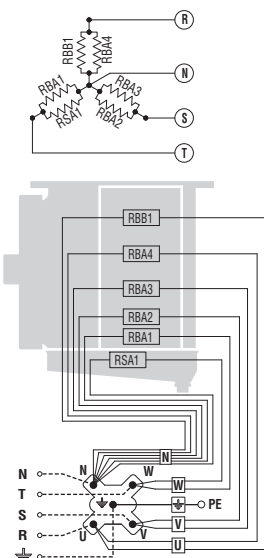

CONNEXION 230V/1/50 Hz  
(à prédisposer)

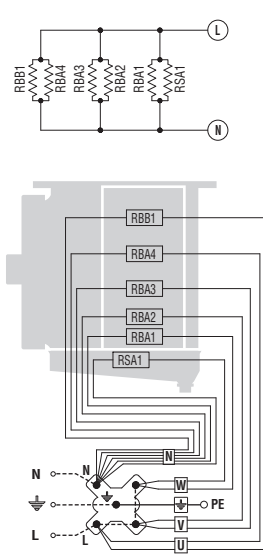

- RBA (1-2-3-4) Résistance de haute puissance dans la batterie.
- RBB1 Résistance de basse puissance dans la batterie.
- RSA1 Résistance de haute puissance sur l'égouttoir interne.

Modèle GCE "ED" ø 350	351 A4	352 A4	353 A4	354 A4	355 A4
	351 A6	352 A6	353 A6	354 A6	355 A6
	351 A8	352 A8	353 A8	354 A8	355 A8
Nappes	6 RR	6 RR	6 RR	6 RR	6 RR
Puissance totale (W)	2750	4950	7700	9900	12100

## Меры предосторожности

1. Храните это техническое Руководство в течение всего срока службы изделия.
2. Прочтите внимательно Руководство перед установкой и перед выполнением любой операции на изделии.
3. Используйте изделие исключительно в целях, для которых оно было разработано: ненадлежащее пользование освобождает изготовителя от всякой ответственности.

## Осмотр - Транспортировка

1. При получении изделия немедленно проверьте его состояние; сразу же уведомите транспортную компанию о возможном ущербе.
2. Во время транспортировки, во избежание неправильного давления на упаковку, она должна всегда находиться в положении, показанном на ней самой.
3. Распаковывайте изделие как можно ближе к месту его установки. Во избежание воздействия на компоненты после распаковки избегайте толчков.
4. Во время установки и перемещения изделия во избежание ранений острыми краями (например, ребра) модели, пользуйтесь соответствующими защитными перчатками.

## Условия для выполнения корректного ввода в эксплуатацию

1. Проверьте герметичность опорных конструкций по отношению к весу прибора.
2. Убедитесь, что изделие установлено горизонтально.
3. Обеспечьте достаточный свободный объем (примерно 30% от внутреннего объема камеры) для корректной циркуляции впускного и выпускного воздуха.

**Особые условия установки или работы в низких камерах, балочных потолочных перекрытиях, чрезмерных складских нагрузках, препятствий на пути потока и/или на аспирации воздуха, неправильное образование инея по причине повышенной влажности в камере, могут отрицательно повлиять на заявленные эксплуатационные характеристики и привести к дефектам изделия. Стандартные модели не могут быть адаптированы для работы в туннелях или скороморозных камерах с интенсивным движением воздуха.**

4. Модели оснащены осевыми мотовентиляторами, непригодными для использования в каналах или, в любом случае, выдерживания дополнительного статического напора.
5. Проверяйте, чтобы условия работы (температура и давление) соответствовали проектным.
6. При выполнении фазы подключений старайтесь не деформировались капилляры и не изменять положение распределителя.
7. В случае использования нескольких моделей, установленных на небольшом расстоянии друг от друга, избегайте цикличности оттайки.
8. Установите на отводах конденсата соответствующие сифоны и проверьте их эффективность при всех рабочих температурах.
9. Избегайте установки воздухоохладителей рядом с дверьми камер.
10. Поместите зонд температуры в более холодные зоны теплообменников, т.е., те в зонах, которые, как правило, замерзают большей частью (в конце цикла лед не должен присутствовать на изделии). Расположение этого устройства не может быть определено заранее, так как оно изменяется в зависимости от типа камер и от типа установки.
11. Убедитесь, что электрическая линия питания имеет одни и те же электрические характеристики, что и прибор.
12. Убедитесь в том, что все электрические соединения соответствуют с действующими нормами.
13. Блоки предназначены для электрического подключения с заземлением. Установщик и/или управляющий блоком обязаны обеспечить наличие эффективного заземления, предохраняющего от косвенного прикосновения, в контакте с проводником. По заявке, модели могут поставлять-

ся с нестандартными теплообменниками, размораживанием и мотовентиляторами. Электрические нагревательные элементы, используемые для размораживания, находятся в распределительной коробке из термопластичного материала и имеют степень защиты IP 54.

14. После завершения установки удалите защитную пленку, покрывающую изделие.
15. Доступ к изделию для любого типа вмешательства в соответствии с действующими нормами должен быть осуществлен только квалифицированным персоналом для ведения монтажа.

## Общее техобслуживание

1. Убедитесь в том, чтобы используемые жидкости и добавки были совместимы с материалами, используемыми для изготовления изделия.
2. Проводите периодическую очистку во избежание скопления вредных веществ. Рекомендуем пользоваться обычным водным раствором с мылом, избегая растворители, агрессивные, абразивные агенты или агенты на основе аммиака.
3. В случае замены электрических нагревателей во время установки во избежание повреждения вулканизации обращайтесь особое внимание на корректное восстановление соединений и систем крепления во избежание их смещения во время работы.

**Эти операции должны выполняться квалифицированным и опытным персоналом.**

## Опасность/ Риски

1.  Опасность поражения электрическим током. Модель оборудована двигателем вентилятора и тэнами электрического оттаивания. Напряжение питания- 400 В (переменный ток). Необходимо соблюдать нормы электробезопасности.
2.  Осторожно. Горячая поверхность. Поверхность тэнов электрического оттаивания может достигать температуры 350 °С.
3.  Осторожно. Возможно травмирование рук. Теплообменное оборудование изготовлено с использованием ребер с острыми краями и имеет корпус, изготовленный из плоских металлических частей.
4.  Осторожно. Возможно затягивание между вращающимися элементами. Модель оборудована двигателем вентилятора с внешней механической защитой.
5.  Осторожно. Падающие предметы. Вес одной единицы может достигать 100кг

## Ссылка на стандарты

- ДИРЕКТИВА О МАШИИНОМ ОБОРУДОВАНИИ 2006/42/ЕС
- ДИРЕКТИВА О НИЗКОВОЛЬТНОМ ОБОРУДОВАНИИ 2014/35/UE
- ДИРЕКТИВА О ЭЛЕКТРОМАГНИТНОЙ СОВМЕСТИМОСТИ 2014/30/UE
- ДИРЕКТИВА ОБ ОБОРУДОВАНИИ, РАБОТАЮЩЕМ ПОД ДАВЛЕНИЕМ 2014/68/UE
- ДИРЕКТИВА ОБ ОБОРУДОВАНИИ, ПРОДУКТЫ ПОТРЕБЛЯЮЩИЕ ЭНЕРГИЮ 2009/125/ЕС

### Внимание

Перед выполнением любой операции техобслуживания убедитесь в том, чтобы электрическое питание было отключено от основного источника: токоведущие части могут быть подключены к устройству автоматического контроля.

## Меры предосторожности для корректной установки

### Минимальное расстояние от стены

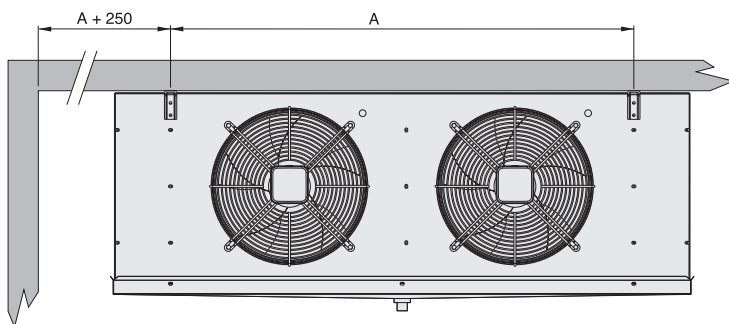

Соблюдайте минимальное расстояние A+250 мм при монтаже.

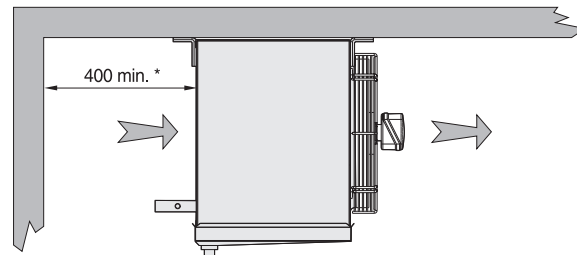

В фазе монтажа соблюдайте минимальное расстояние в 400 мм для эффективной работы двигателя.

## Конструктивные и габаритные характеристики

### Модель с крыльчаткой Ø 250 мм

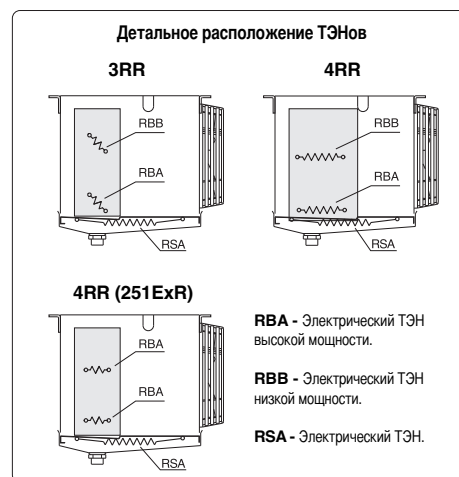
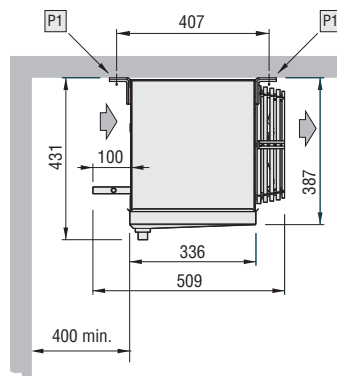
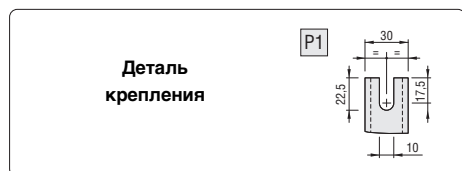
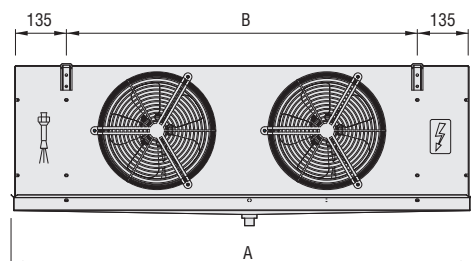

Модель	GCE	251 E4R	251 E4	252 G4	252 E4	253 G4	253 E4	254 G4	254 E4
		251 E6R	251 E6	252 G6	252 E6	253 G6	253 E6	254 G6	254 E6
		251 E8R	251 E8	252 G8	252 E8	253 G8	253 E8	254 G8	254 E8
Мотовентиляторы	н° x Ø mm	1x250	1x250	2x250	2x250	3x250	3x250	4x250	4x250
Размеры	A	674	774	1224	1224	1674	1674	2124	2124
	B	380	480	930	930	1380	1380	1830	1830
Подсоединения теплообменника	In tube (mm)	12	12	12	12	12	12	12	16
	Out tube (mm)	12	12	22	22	22	22	22 (G4: 28)	28
Подсоединение выпуска	Ø (GAS)	1"	1"	1"	1"	1"	1"	1"	1"
Чистый вес	kg	13	14,5	21,5	24	30	33	38	41,5

Используйте термостатический клапан с внешним уравнивателем давления

## Конструктивные и габаритные характеристики

### Модель с крыльчаткой Ø 315 мм

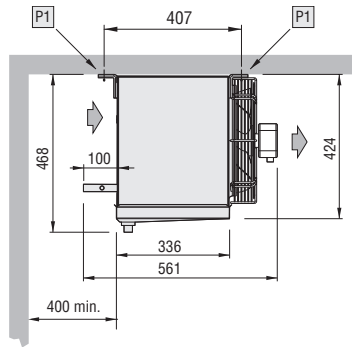
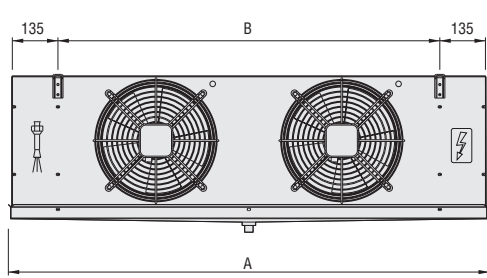

#### Детальное расположение ТЭНов

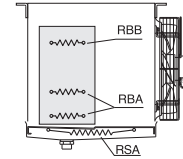

RBA - Электрический ТЭН высокой мощности.  
RBB - Электрический ТЭН низкой мощности.  
RSA - Электрический ТЭН.



Модель	GCE	311F4		312F4		313F4		314F4	
		311F6	311F8	312F6	312F8	313F6	313F8	314F6	314F8
Мотовентиляторы	n° x Ø mm	1x315		2x315		3x315		4x315	
Размеры	A	874		1424		1974		2524	
	B	580		1130		1680		2230	
Подсоединения теплообменника	In tube (mm)	12		12		16		16 (F4: 22)	
	Out tube (mm)	22		28		28		28 (F8: 35)	
Подсоединение выпуска		1"		1"		1"		1"	
Чистый вес	kg	20		34		47,5		61	

Используйте термостатический клапан с внешним уравнивателем давления

### Модель с крыльчаткой Ø 350 мм

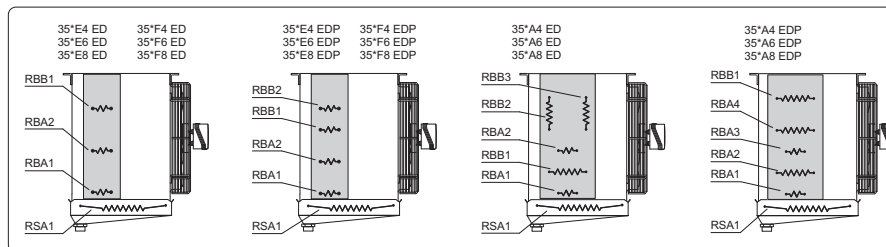
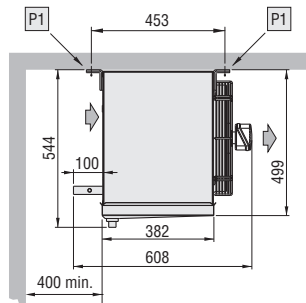
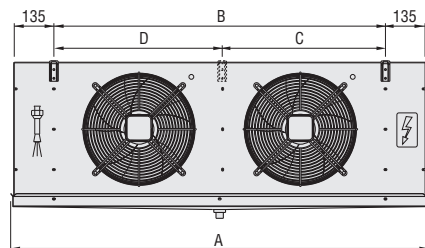

#### Детальное расположение ТЭНов

RBA - Электрический ТЭН высокой мощности.  
RBB - Электрический ТЭН низкой мощности.  
RSA - Электрический ТЭН.

Modello	GCE	351 E4	351A4	352 E4	352 A4	353 F4	353A4	354 F4	354 A4	355 A4
		351 E6	351A6	352 E6	352 A6	353 F6	353A6	354 F6	354 A6	355 A6
		351 E8	351A8	352 E8	352 A8	353 F8	353A8	354 F8	354 A8	355 A8
Мотовентиляторы	n° x Ø	1x350		2x350		3x350		4x350		5x350
Dimensioni	A mm	875	875	1425	1425	1975	1975	2525	2525	3075
	B mm	580	580	1130	1130	1680	1680	2230	2230	2780
	C mm	-	-	-	-	-	-	1115	1115	1665
	D mm	-	-	-	-	-	-	1115	1115	1115
Подсоединения теплообменника	In tube (mm)	12	12	16	16	16 (F4: 22)	22	22	28	28
	Out tube (mm)	22	22	28	28	28 (F8: 35)	35	35 (F8: 42)	42	42
Attacco scarico	Ø (GAS)	1	1	1	1	1	1	1	1	1
Peso netto	kg	22	26,5	41	48	58	63	77	83,5	103

Используйте термостатический клапан с внешним уравнивателем давления

## Схема подключения мотовентиляторов

### Внимание

Двигатели оснащены встроенными термодатчиками тепловой защиты с автоматической перезагрузкой.

Перед использованием системы регулирования числа оборотов двигателей проверьте совместимость с самими двигателями, несовместимые системы могут создавать шумы и повреждения; компания производителя не несет никакой ответственности по производительности моделей, оснащенных системами управления.

Модель GCE	251 E4R	251 E4	252G4	252 E4	253G4	253 E4	254G4	254 E4	311F4		312F4		313F4		314F4		
	251 E6R	251 E6	252G6	252 E6	253G6	253 E6	254G6	254 E6	311F6		312F6		313F6		314F6		
	251 E8R	251 E8	252G8	252 E8	253G8	253 E8	254G8	254 E8	311F8		312F8		313F8		314F8		
Мотовентиляторы	1 x 250		2 x 250		3 x 250		4 x 250		1 x 315		2 x 315		3 x 315		4 x 315		
Частота	Hz	50	60	50	60	50	60	50	60	50	60	50	60	50	60	50	60
Потребление мотовентиляторов	A	0,68	-	1,36	-	2,04	-	2,72	-	0,52	0,66	1,04	1,32	1,56	1,98	2,08	2,64
	W	95	-	190	-	285	-	380	-	110	148	220	296	330	444	440	592
RPM		1300	1550	1300	1550	1300	1550	1300	1550	1350	1490	1350	1490	1350	1490	1350	1490

Модель GCE	351 E4	351A4	352 E4	352 A4	353 F4	353A4	354 F4	354 A4	355 A4		
	351 E6	351A6	352 E6	352 A6	353 F6	353A6	354 F6	354 A6	355 A6		
	351 E8	351A8	352 E8	352 A8	353 F8	353A8	354 F8	354 A8	355 A8		
Мотовентиляторы	1 x 350		2 x 350		3 x 350		4 x 350		5 x 350		
Частота	Hz	50	60	50	60	50	60	50	60	50	60
Потребление мотовентиляторов	A	0,96	1,08	1,92	2,16	2,88	3,24	3,84	4,32	4,80	5,40
	W	185	250	370	500	555	750	740	1000	925	1250
RPM		1420	1660	1420	1660	1420	1660	1420	1660	1420	1660

### Схема подключения мотовентиляторов Ø 250 мм

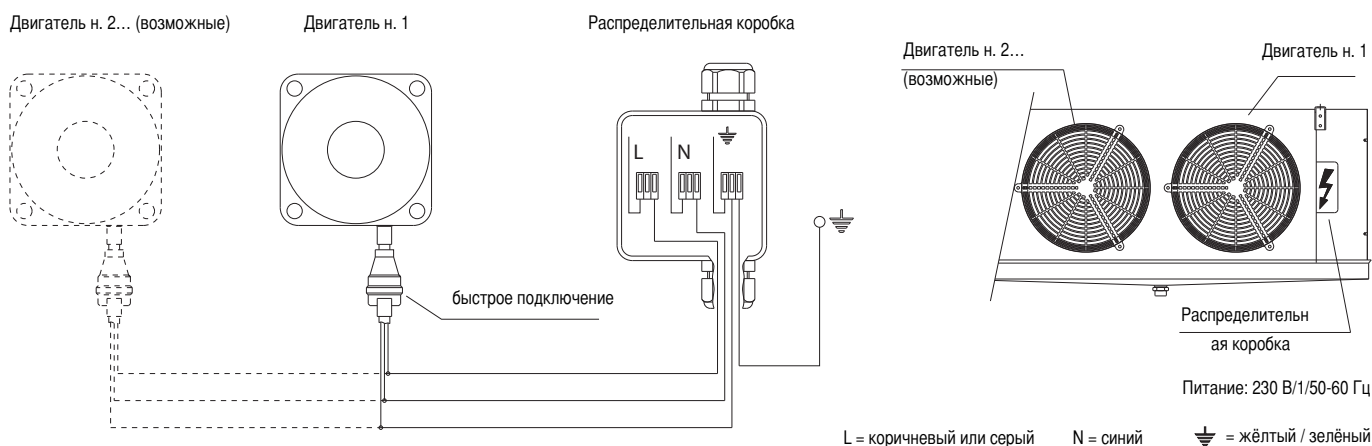

### Схема подключения мотовентиляторов Ø 315 - 350 мм

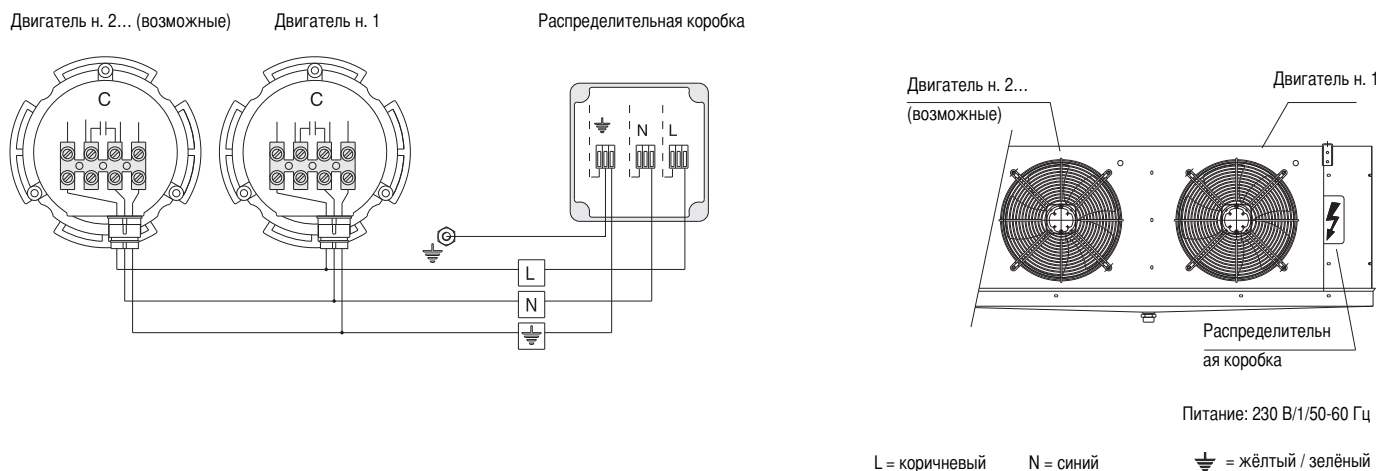

## Рекомендации по корректному доступу к аппарату

### Доступ

1. Демонтируйте выпускную трубу слива конденсата.
2. Перед удалением и отвинчиванием винтов "А" убедитесь в том, что лоток будет свободным от возможных остатков льда.
3. Ослабьте самозавинчивающиеся винты "В", не вынимая их полностью, далее выньте боковую крышку.

### Повторное позиционирование

1. Установите заново боковую крышку и закрепите её посредством винтов "В".
2. Установите лоток, стараясь, чтобы боковые крышки располагались внутри его, далее укрепите его винтами "А".
3. Установите заново выпускную трубу конденсата.

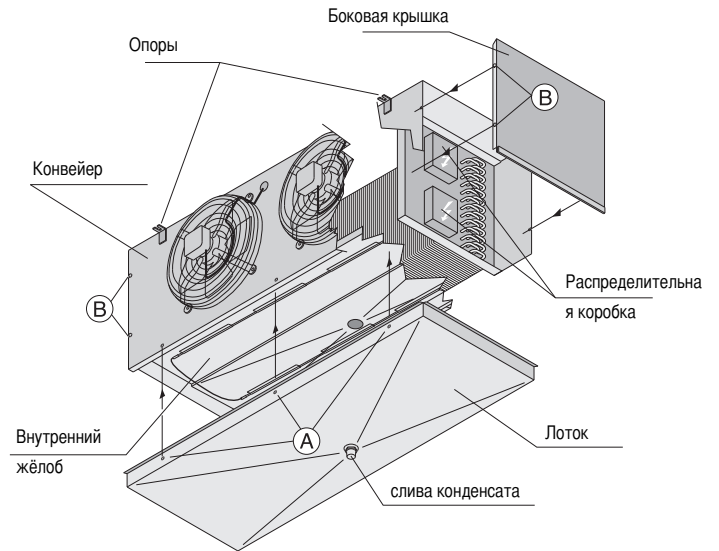

## Схема подключений и мощностей электрических ТЭНов

### Внимание

Использование соответствующих систем тепловой защиты от линий питания является обязательным.

Для предотвращения вредных скоплений льда на изделиях проводите периодические проверки функциональности всех нагревательных элементов. Компания производителя не несёт никакой ответственности за дефекты, приводящие к невыявленным неисправностям.

### Модель с крыльчаткой Ø 250 мм

### ПОДКЛЮЧЕНИЕ 400V/3/50 Hz ПОДГОТОВЛЕНО

GCE 251ExR

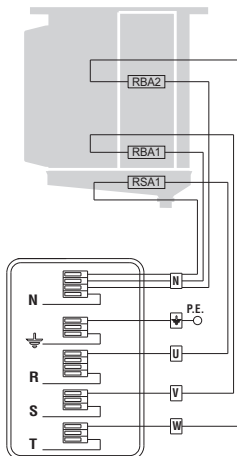
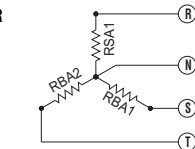

GCE 252Gx  
253Gx  
254Gx

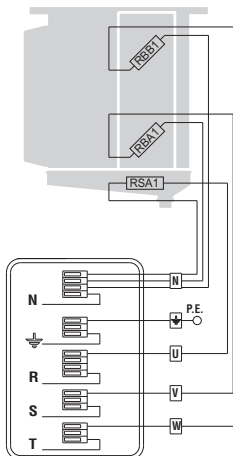
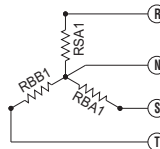

GCE 251Ex  
252Ex  
253Ex  
254Ex

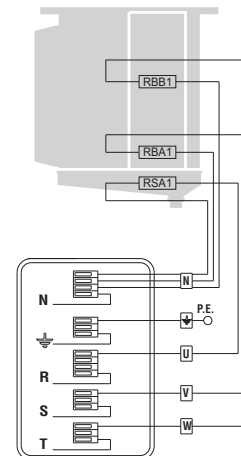
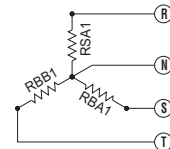

**RBA (1-2)** Электрический ТЭН высокой мощности.  
**RBB1** Электрический ТЭН низкой мощности.  
**RSA1** Электрический ТЭН.

Модель GCE "ED" ø 250	251E4R	251E4	252G4	252E4	253G4	253E4	254G4	254E4
	251E6R	251E6	252G6	252E6	253G6	253E6	254G6	254E6
	251E8R	251E8	252G8	252E8	253G8	253E8	254G8	254E8
Ряды	4 RR	4 RR	3 RR	4 RR	3 RR	4 RR	3 RR	4 RR
Общая мощность (Вт)	750	1125	2250	2250	3325	3325	4375	4375



## Схема подключений и мощностей электрических ТЭНов

### Внимание

Использование соответствующих систем тепловой защиты от линий питания является обязательным.

Для предотвращения вредных скоплений льда на изделиях проводите периодические проверки функциональности всех нагревательных элементов. Компания производителя не несёт никакой ответственности за дефекты, приводящие к невыявленным неисправностям.

### Модель с крыльчаткой Ø 250 мм

#### ПОДКЛЮЧЕНИЕ 230V/1/50 Hz ДЛЯ ПОДГОТОВКИ

GCE 251ExR

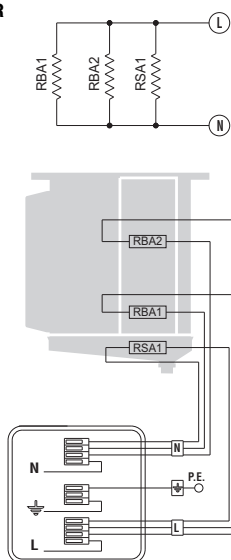

GCE 252Gx  
253Gx  
254Gx

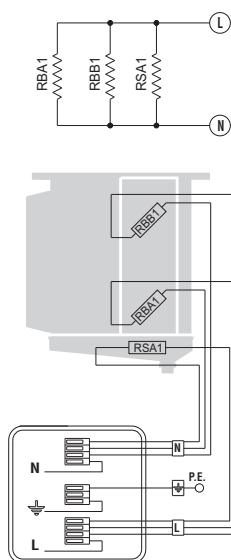

GCE 251Ex  
252Ex  
253Ex  
254Ex

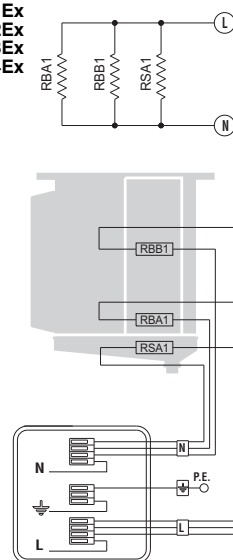

**RBA (1-2)** Электрический ТЭН высокой мощности.  
**RBB1** Электрический ТЭН низкой мощности.  
**RSA1** Электрический ТЭН.

Модель GCE "ED" ø 250	251E4R	251E4	252G4	252E4	253G4	253E4	254G4	254E4
	251E6R	251E6	252G6	252E6	253G6	253E6	254G6	254E6
	251E8R	251E8	252G8	252E8	253G8	253E8	254G8	254E8
Ряды	4 RR	4 RR	3 RR	4 RR	3 RR	4 RR	3 RR	4 RR
Общая мощность (Вт)	750	1125	2250	2250	3325	3325	4375	4375

### Модель с крыльчаткой Ø 315 мм

#### ПОДКЛЮЧЕНИЕ 400V/3/50 Hz (подготовлено)

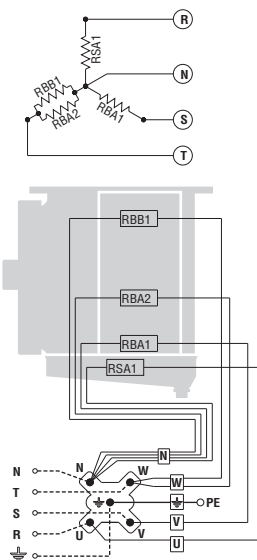

#### ПОДКЛЮЧЕНИЕ 230V/1/50 Hz (для подготовки)

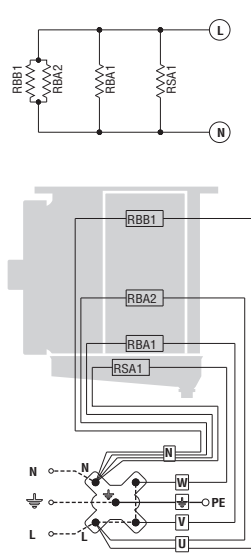

**RBA (1-2)** Электрический ТЭН высокой мощности.  
**RBB1** Электрический ТЭН низкой мощности.  
**RSA1** Электрический ТЭН.

Модель GCE "ED" ø 315	311F4	312F4	313F4	314F4
	311F6	312F6	313F6	314F6
	311F8	312F8	313F8	314F8
Ряды	5 RR	5 RR	5RR	5 RR
Общая мощность (Вт)	1750	3150	4900	6300

## Схема подключений и мощностей электрических ТЭНов

### Внимание

Использование соответствующих систем тепловой защиты от линий питания является обязательным.

Для предотвращения вредных скоплений льда на изделиях проводите периодические проверки функциональности всех нагревательных элементов. Компания производителя не несёт никакой ответственности за дефекты, приводящие к невыявленным неисправностям.

### Модель с крыльчаткой Ø 350 мм

### 4-5 RR standard

#### ПОДКЛЮЧЕНИЕ 400V/3/50 Hz (подготовлено)

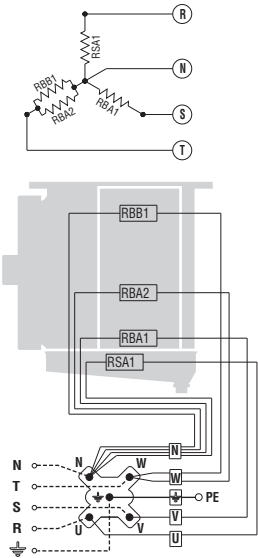

#### ПОДКЛЮЧЕНИЕ 230V/1/50 Hz (для подготовки)

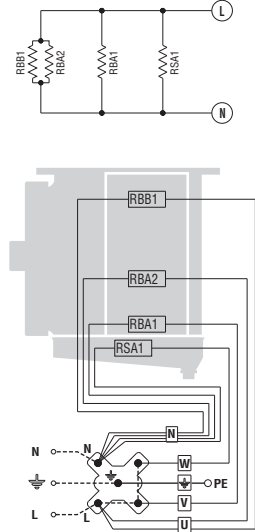

**RBA (1-2)** Электрический ТЭН высокой мощности.  
**RBB1** Электрический ТЭН низкой мощности.  
**RSA1** Электрический ТЭН.

Модель GCE "ED" ø 350	351 E4	352 E4	353 F4	354 F4
	351 E6	352 E6	353 F6	354 F6
	351 E8	352 E8	353 F8	354 F8
Ряды	4 RR	4 RR	5 RR	5 RR
Общая мощность (Вт)	1750	3150	4900	6300

### Модель с крыльчаткой Ø 350 мм

### 4-5 RR strengthen

#### ПОДКЛЮЧЕНИЕ 400V/3/50 Hz (подготовлено)

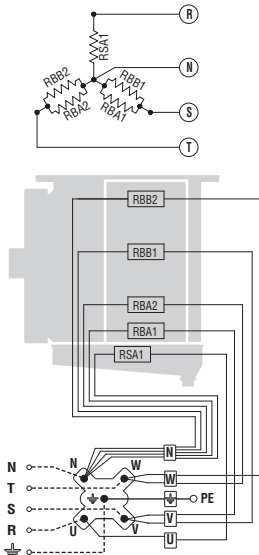

#### ПОДКЛЮЧЕНИЕ 230V/1/50 Hz (для подготовки)

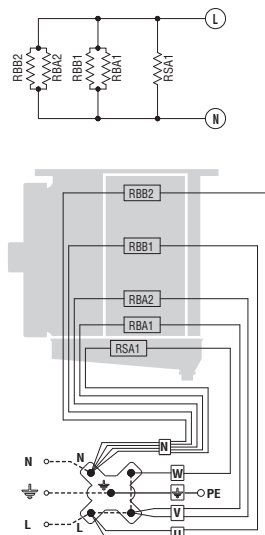

**RBA (1-2)** Электрический ТЭН высокой мощности.  
**RBB (1-2)** Электрический ТЭН низкой мощности.  
**RSA1** Электрический ТЭН.

Модель GCE "ED" ø 350	351 E4	352 E4	353 F4	354 F4
	351 E6	352 E6	353 F6	354 F6
	351 E8	352 E8	353 F8	354 F8
Ряды	4 RR	4 RR	5 RR	5 RR
Общая мощность (Вт)	2000	3600	5600	7200

## Схема подключений и мощностей электрических ТЭНов

### Внимание

Использование соответствующих систем тепловой защиты от линий питания является обязательным.

Для предотвращения вредных скоплений льда на изделиях проводите периодические проверки функциональности всех нагревательных элементов. Компания производителя не несёт никакой ответственности за дефекты, приводящие к невыявленным неисправностям.

### Модель с крыльчаткой Ø 350 мм

### 6 RR standard

#### ПОДКЛЮЧЕНИЕ 400V/3/50 Hz (подготовлено)

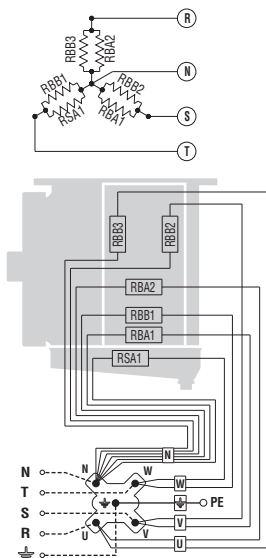

#### ПОДКЛЮЧЕНИЕ 230V/3/50 Hz (для подготовки)

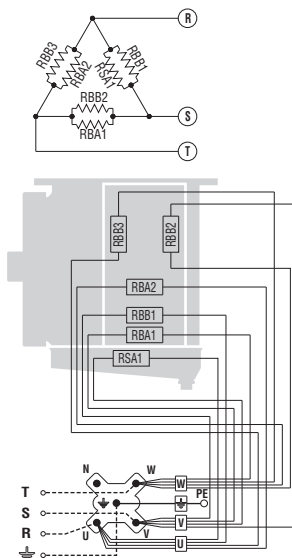

#### ПОДКЛЮЧЕНИЕ 230V/1/50 Hz (для подготовки)

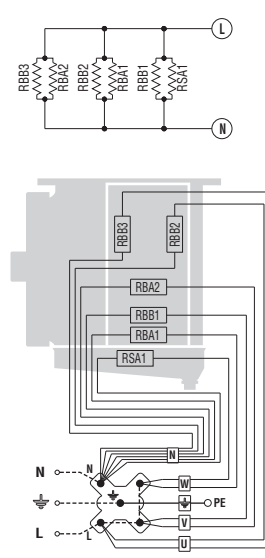

- RBA (1-2) Электрический ТЭН высокой мощности.
- RBB (1-2-3) Электрический ТЭН низкой мощности.
- RSA1 Электрический ТЭН.

Модель GCE "ED" ø 350	351 A4	352 A4	353 A4	354 A4	355 A4
	351 A6	352 A6	353 A6	354 A6	355 A6
	351 A8	352 A8	353 A8	354 A8	355 A8
Ряды	6 RR	6 RR	6 RR	6 RR	6 RR
Общая мощность (Вт)	2250	4050	6300	8100	9900

### Модель с крыльчаткой Ø 350 мм

### 6 RR strengthen

#### ПОДКЛЮЧЕНИЕ 400V/3/50 Hz (подготовлено)

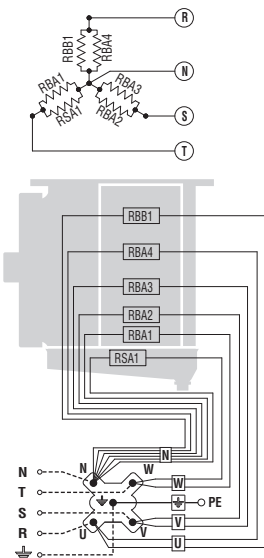

#### ПОДКЛЮЧЕНИЕ 230V/1/50 Hz (для подготовки)

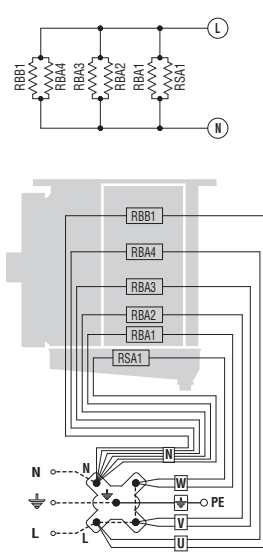

- RBA (1-2-3-4) Электрический ТЭН высокой мощности.
- RBB1 Электрический ТЭН низкой мощности.
- RSA1 Электрический ТЭН.

Модель GCE "ED" ø 350	351 A4	352 A4	353 A4	354 A4	355 A4
	351 A6	352 A6	353 A6	354 A6	355 A6
	351 A8	352 A8	353 A8	354 A8	355 A8
Ряды	6 RR	6 RR	6 RR	6 RR	6 RR
Общая мощность (Вт)	2750	4950	7700	9900	12100

- **AEROEVAPORATORI** / unit cooler / Luftverdampfer / aéroévaporateur / aereovaporador -

	<b>Codice</b> Code - Code Typ - Código  <b>Numero di matricola</b> Part number - Numéro de série Seriennummer - Número de serie	<b>Data</b> Date - Datum Date - Fecha
--	---	---

**DICHIARAZIONE DI INCORPORAZIONE (2006/42/EC - II B)**

DECLARATION OF INCORPORATION - EINBAUERERKLÄRUNG - DECLARATION D'INCORPORATION - DECLARACIÓN DE INCORPORACIÓN

Il fabbricante dichiara che l'aereovaporatore qui identificato dal codice e numero di matricola:

- non deve essere messo in servizio finché la macchina in cui sarà incorporato non sia stata dichiarata conforme alla direttiva 2006/42/CE;
- sono stati applicati e rispettati i seguenti requisiti essenziali della direttiva macchine 2006/42/EC (1.1.3, 1.1.5, 1.3.1, 1.3.4, 1.3.7, 1.3.8, 1.5.1);
- è conforme alle disposizioni della direttiva 2014/35/UE
- è conforme alle disposizioni della direttiva 2014/30/UE
- è conforme alle disposizioni della direttiva 2014/68/UE, Modulo A per Cat. I oppure Art. 4 Par. 3, come indicato su etichetta dati PED scambiatore;
- è conforme alle disposizioni della direttiva 2009/125/EC

The manufacturer declares that the unit cooler hereby identified by code and part number:

- must not be set into operation until the machine into which it will be incorporated has been declared in accordance with the provisions stated in directive 2006/42/EC;
- that the following essential requirements of Machinery Directive 2006/42/EC (1.1.3, 1.1.5, 1.3.1, 1.3.4, 1.3.7, 1.3.8, 1.5.1) have been duly applied and fulfilled;
- complies with the provisions of revised directive 2014/35/UE
- complies with the provisions of revised directive 2014/30/UE
- complies with the provisions of revised directive 2014/68/UE, Module A for Cat. I or Art.4 Par. 3, as indicated on the heat-exchanger's PED data label;
- complies with the provisions of revised directive 2009/125/EC

Der Hersteller erklärt, dass dieser hier mit Typ und Seriennummer gekennzeichnete Luftverdampfer:

- solange nicht in Betrieb genommen werden darf, bis die Maschine oder Anlage, in welche dieser eingebaut wird, den Bestimmungen der Richtlinie 2006/42/EC entspricht;
- die folgenden grundlegenden Anforderungen der Maschinenrichtlinie 2006/42/EC (1.1.3, 1.1.5, 1.3.1, 1.3.4, 1.3.7, 1.3.8, 1.5.1) zur Anwendung kommen und eingehalten werden;
- den Bestimmungen der Richtlinie 2014/35/UE entspricht;
- den Bestimmungen der Richtlinie 2014/30/UE entspricht;
- den Bestimmungen der Richtlinie 2014/68/UE, Vorgang A für Kategorie I oder Artikel 4 Absatz 3 entspricht, gemäß Angaben auf der PED Etikette des Wärmeaustauschers;
- den Bestimmungen der Richtlinie 2009/125/EC

Le fabricant déclare que le aéroévaporateur ici identifié par son code et numéro de série:

- ne doit pas être mis en service avant que la machine dans laquelle il sera incorporé ne soit déclarée conforme aux dispositions de la directive 2006/42/EC;
- ont été appliquées et respectées les exigences essentielles suivantes de la directive machines 2006/42/EC (1.1.3, 1.1.5, 1.3.1, 1.3.4, 1.3.7, 1.3.8, 1.5.1);
- est conforme aux dispositions de la directive 2014/35/UE;
- est conforme aux dispositions de la directive 2014/30/UE;
- est conforme aux dispositions de la directive 2014/68/UE, Module A pour Cat. I ou Art.4 Par.3, comme indiqué sur étiquette données PED échangeur;
- est conforme aux dispositions de la directive 2009/125/EC

El fabricante declara que el aereovaporador aquí identificado por el código y número de serie:

- no se tiene que poner en marcha hasta que la máquina en la cual se instalará sea declarada conforme a las condiciones indicadas en la norma 2006/42/EC;
- se han aplicado y cumplido los siguientes requisitos esenciales de la directiva de máquinas 2006/42/EC (1.1.3, 1.1.5, 1.3.1, 1.3.4, 1.3.7, 1.3.8, 1.5.1);
- es conforme a las condiciones de la norma 2014/35/UE;
- es conforme a las condiciones de la norma 2014/30/UE;
- es conforme a las condiciones de la norma 2014/68/UE, Módulo A para Categoría I, o Art.4 Par. 3, como indicado en la etiqueta datos PED intercambiador.
- es conforme a las condiciones de la norma 2009/125/EC

**ATTESTATO DI COLLAUDO**

TEST CERTIFICATE - ABNAHMEZEUGNIS - ATTESTATION D'ESSAIS - CERTIFICADO DE CONFORMIDAD DE LA PRUEBA

Il fabbricante dichiara che il modello qui identificato per codice e numero di matricola ha superato con esito positivo i collaudi funzionali e di sicurezza elettrica, secondo le norme sotto indicate, e assegnate a ciascun modello in base al suo allestimento elettrico.

The manufacturer attests that the model hereby identified by code and part number has passed the relevant operating and electrical safety tests in accordance with the following standards, which are assigned to each model based on its electrical configuration.

Der Hersteller erklärt, dass das hier nach Typ und Seriennummer angegebene und je nach elektrischer Ausstattung zugeordnete Modell das funktionsgerechte Abnahmeverfahren sowie das der elektrischen Sicherheit gemäß den u. g. Richtlinien erfolgreich bestanden hat.

Le fabricant déclare que le modèle ici identifié par son code et numéro de série a passé avec succès les essais fonctionnels et de sécurité électrique, conformément aux normes indiquées ci-dessous et appliquées à chaque modèle en fonction de son équipement électrique.

El fabricante declara que el modelo aquí identificado por el código y número de serie ha superado las pruebas funcionales y de seguridad eléctrica, de acuerdo con las siguientes normas, asignadas a cada modelo según su instalación eléctrica.

CEI EN 60335-1 (R < 0,1Ω) per tutti i modelli - for all machines - für alle Geräte - pour toutes les machines - para todas las máquinas

CEI EN 60204-1 (R > 1MΩ) per tutti i modelli - for all machines - für alle Geräte - pour toutes les machines - para todas las máquinas

CEI EN 60204-1 (R < Rm) solo per i modelli cablati - only for wired machines - nur für verkabelte Geräte - pour les machines câblées - para las máquinas cableadas

CEI EN 60335-1 (I < 5mA) solo per i modelli cablati, equipaggiati con componenti a bassa dispersione funzionale - only for wired machines, equipped with low dispersion components - nur für verkabelte Geräte mit Funktionskomponenten mit niedriger Dispersion ausgestattet - pour les machines câblées, équipées de composants à faible dispersion - para máquinas cableadas, equipadas con componentes de baja dispersión

CEI EN 60335-2-40 (I < 10mA, I < 30mA) solo per i modelli cablati, equipaggiati con componenti ad alta dispersione funzionale - only for wired machines, equipped with high dispersion components - nur für verkabelte Geräte mit Funktionskomponenten mit hoher Dispersion ausgestattet - pour les machines câblées, équipées de composants de haute dispersion - para máquinas cableadas, equipadas con componentes de alta dispersión

**Modine CIS Italy S.r.l.**

**Persona autorizzata a costituire la documentazione tecnica pertinente (ANNEX II B.5)**

Person authorised to compile the relevant technical documentation  
Bevollmächtigte Person, die die relevanten technischen Unterlagen zusammenstellt  
Personne autorisée à constituer le dossier technique en question  
Persona facultada para elaborar la documentación técnica pertinente  
Roberto Benedetti

**Modine CIS Italy S.r.l.**

Il Legale Rappresentante

Legal Representative - Der gesetzliche Vertreter

Le Représentant Légal - El Representante Legal

Laura Puntin

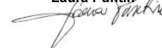

Данный продукт соответствует требованиям  
"О безопасности оборудования, работающего под избыточным давлением"  
Регистрационный номер декларации о соответствии **TC N° RU Д-IT.MO1062.B.04631**  
Дата регистрации декларации о соответствии **16.01.2018**  
декларация о соответствии действительна с даты регистрации ио **15.01.2023** включительно

Изготовитель: Modine CIS Italy S.r.l.  
Адрес: Via Giulio Locatelli, 22 / 33050 Pocenia (Udine) / Italy  
Тел. +39 0432 772 001  
Факс +39 0432 779 594

This product complies with "The safety of the equipment operating under high pressure"  
Registration number of the Declaration of Conformity **TC N° RU Д-IT.MO1062.B.04631**  
Registration date of Declaration of Conformity **16.01.2018**  
Declaration of Conformity is valid until the **15.01.2023** included

Manufacturer: Modine CIS Italy S.r.l.  
Address: Via Giulio Locatelli, 22 / 33050 Pocenia (Udine) / Italy  
Tel. +39 0432 772 001  
Fax +39 0432 779 594

## Garanzie

Tutte le informazioni tecniche presenti in questa edizione sono basate su prove che riteniamo ampie e attendibili, ma che non possono essere riferite a tutta la casistica dei possibili impieghi. Pertanto, l'acquirente deve accertare l' idoneità del prodotto all'uso per il quale intende destinarlo, assumendo ogni responsabilità derivante dall'utilizzo dello stesso. La società venditrice, su richiesta dell'acquirente, si renderà disponibile fornendo tutte le informazioni utili per il migliore utilizzo dei suoi prodotti. Tutti i nostri modelli sono garantiti per due anni dalla data di fatturazione degli stessi; si prega di contattare la sede legale di Modine CIS Italy S.r.l. per un maggior approfondimento. Sono ad ogni modo escluse da ogni forma di garanzia le avarie occasionali quali quelle dovute al trasposto, le manomissioni da parte di personale non autorizzato, l'utilizzo non corretto e le errate installazioni a cui vengano sottoposti i prodotti.

*La costante ricerca svolta dai nostri laboratori per garantire prodotti sempre migliori e innovativi potrebbe causare la modifica dei dati qui contenuti. Sarà dunque compito dell'utilizzatore mantenersi aggiornato sulla loro validità.*

*Nessuna parte di questa pubblicazione può essere riprodotta o imitata senza autorizzazione. Decliniamo ogni responsabilità per eventuali errori di stampa o omissioni e ci riserviamo il diritto di apportare senza preavviso e in qualsiasi momento le modifiche che riterremo opportune.*

## Gewährleistung

Alle technischen Informationen in dieser Ausgabe basieren auf Tests, die wir für weit gefächert und zuverlässig halten, aber nicht alle möglichen Anwendungen einbeziehen können. Daher muss der Käufer die Eignung des Produkts für den Zweck, für den es bestimmt ist, überprüfen, und die gesamte Verantwortung für die Verwendung derselben übernehmen. Der Verkäufer steht auf Anfrage des Käufers zur Verfügung, alle nützlichen Informationen für die beste Anwendung seiner Produkte zu erteilen. Alle unsere Produkte sind für zwei Jahre ab dem Rechnungsdatum der Produkte garantiert; für weitere Informationen konsultieren das Rechtsbüro von Modine CIS Italy S.r.l. Von jeder Form der Garantie ausgeschlossen sind auf alle Fälle eventuelle Beschädigungen durch den Transport, Manipulationen durch nicht autorisiertes Personal, nicht korrekter Gebrauch und fehlerhafte Installationen.

*Durch die ständige Forschung unserer Labors, um immer bessere und innovativere Produkte zu garantieren, kann es zur Änderung der hier beinhaltenden Daten kommen, es ist daher Aufgabe des Benutzers sich über die Gültigkeit auf dem Laufenden zu halten.*

*Kein Teil dieser Veröffentlichung darf ohne Genehmigung wiedergegeben oder nachgeahmt werden, wir lehnen jede Verantwortung für eventuelle Druck- oder Schreibfehler ab und behalten uns das Recht vor, jederzeit und ohne vorherige Benachrichtigung Änderungen vorzunehmen, die wir für zweckmäßig halten.*

## Warranty

All technical information in this edition is based on tests carried out, which we deem exhaustive and reliable but which cannot be referred to all records of possible applications. Therefore, the purchaser must ascertain product suitability with regard to its intended use, undertaking all responsibility arising from its said use. Upon request by the purchaser, the seller shall be available to supply all useful information in order to use his products better. All our models have a two-year warranty with effect from the date of the said invoice. Please refer to the Legal Office of Modine CIS Italy S.r.l. for more in-depth information. However, occasional failures such as those due to transport, tampering by unauthorised personnel, incorrect use and incorrect installation, which the products are subjected to, are all excluded from any form of warranty.

*As a result of continuing research and design by our technical laboratories, aimed at offering top quality and innovative products, the information given in this guide may be subject to modification at any time without prior notice; it is up to the user to keep up to date on all possible modifications.*

*No part of this publication may be reproduced or duplicated without prior permission; we decline any responsibility for possible mistakes or omissions, and we reserve the right to make amendments deemed necessary, without prior notice and at any time.*

## Garantias

Todas las informaciones técnicas presentes en esta edición se basan en pruebas que consideramos extensas y fiables, pero que no pueden tomarse como referencia para toda la variedad de posibles aplicaciones. Por lo tanto, el comprador debe comprobar la compatibilidad del producto con el uso para el que pretende destinarlo, asumiendo toda la responsabilidad derivada del uso del mismo. El vendedor estará a disposición del comprador para cualquier información útil que pueda servir para el mejor uso posible de sus productos. Todos nuestros modelos cuentan con una garantía de dos años desde la fecha de facturación de los mismos. Para más información, se ruega consultar la Oficina Legal de Modine CIS Italy S.r.l. Quedan excluidas de cualquier forma posible de garantía las averías fortuitas que puedan sufrir los productos, como las debidas al transporte, a la manipulación por parte de personal no autorizado, a un uso no adecuado y a una instalación incorrecta.

*En nuestros laboratorios se trabaja sin interrupción para garantizar la mejora y la innovación de los productos. Esto podría causar la modificación de algunos de los datos de esta guía. Por lo tanto, aconsejamos al usuario averiguar siempre la actualización y validez de los mismos.*

*Está prohibido imitar o reproducir el contenido del presente sin previa autorización. Declinamos cualquier responsabilidad por errores de impresión o de transcripción y omisiones y nos reservamos el derecho de aportar en cualquier momento, sin aviso, los cambios que se estime oportuno.*

## Garantie

Toutes les informations techniques présentes dans cette édition sont basées sur des essais que nous considérons complets et fiables, mais qui ne peuvent pas se référer à tous les cas possibles d'emploi. C'est pourquoi, l'acheteur doit vérifier la conformité du produit à l'usage auquel il souhaite le destiner, en se chargeant de toute responsabilité découlant de l'utilisation de celui-ci. Le vendeur, à la demande de l'acheteur, restera à disposition en fournissant toutes les informations utiles pour assurer une utilisation optimale de ses produits. Tous nos modèles sont garantis pendant deux ans à compter de la date de facturation de ceux-ci; veuillez consulter le Bureau Juridique de Modine CIS Italy S.r.l. pour obtenir plus de détails. Sont qu'il en soit exclues de toute forme de garantie: les pannes occasionnelles telles que celles dues au transport, les altérations de la part d'un personnel non autorisé, l'utilisation incorrecte et les mauvaises installations auxquelles les produits sont soumis.

*La recherche constante de nos laboratoires visant à garantir des produits toujours meilleurs et innovants pourrait causer la modification des données contenues ici. Il incombera à l'utilisateur de se tenir informé sur leur validité.*

*Aucune partie de cette publication ne peut être reproduite ou imitée sans autorisation. Nous déclinons toute responsabilité pour d'éventuelles erreurs d'impression ou omissions et nous réservons le droit d'apporter sans préavis et à tout moment les modifications que nous retiendrons opportunes.*

## Гарантия

Вся техническая информация, представленная в настоящем издании, основана на опыте изготовителя, который он считает богатым и исчерпывающим, но который может не отвечать всем возможным целям применения. Поэтому пользователь должен убедиться, что изделие подходит для предназначенных целей, и принять всю ответственность для эксплуатации прибора. Компания-продавец, по заявке покупателя предоставляет всю необходимую информацию для улучшения эксплуатации собственных изделий. Все наши модели покрываются гарантией сроком на два года с даты выставления счета-фактуры; мы рекомендуем вам обратиться в Modine CIS Italy S.r.l. Legal Office. Гарантией в любом случае не покрывается ремонт, выполненный при повреждениях в результате перевозки, разборках, выполненных неуполномоченным персоналом, неправильным применением и установке, которым подвергается изделие.

*В связи с непрерывными исследованиями и разработками, нацеленными на совершенствование нашей продукции, информация, представленная в данной публикации, в любой момент может быть изменена без уведомления. Следить за такими изменениями – задача заказчика.*

*Никакая часть данной публикации не может быть воспроизведена или скопирована без предварительного полученного разрешения. Мы не несем ответственности за возможные ошибки и пропуски и сохраняем право вносить необходимые исправления в любое время без уведомления.*



A series of horizontal dotted lines for writing.



Manufacturer:

Modine CIS Italy S.r.l.

33050 Pocenia - Udine - Italy

Via Giulio Locatelli, 22

Tel. +39 0432.772.001

Fax +39 0432.779.594

GCEM1801A07P\_M

MN263464