

Ver. | - - -



IMPORTANT NOTE:

Read this manual carefully before installing or operating your new air conditioning unit. Make sure to save this manual for future reference.

Table of Contents

Part I : Technical Information

| | |
|--|----|
| 1. Summary | 1 |
| 2. Specifications | 2 |
| 3. Outline Dimension Diagram | 16 |
| 4. Refrigerant System Diagram | 18 |
| 5. Electrical Part | 22 |
| 5.1 Wiring Diagram | 22 |
| 5.2 PCB Printed Diagram | 26 |
| 6. Function and Control | 29 |

Part II : Installation and Maintenance

| | |
|---|----|
| 7. Notes for Installation and Maintenance | 31 |
| 8. Installation | 36 |
| 8.1 Electrical Connections | 37 |
| 8.2 Installing the Outdoor Unit | 39 |
| 8.3 Installation Dimension Diagram..... | 40 |
| 8.4 Check after Installation | 41 |
| 9. Maintenance | 42 |
| 9.1 Precautions before Performing Inspection or Repair | 42 |
| 9.2 Flashing LED of Indoor/Outdoor Unit and Primary Judgement | 43 |
| 9.3 Malfunction Checking and Elimination | 44 |
| 9.4 Troubleshooting for Normal Malfunction | 56 |
| 10. Exploded View and Parts List | 58 |
| 11. Removal Procedure | 72 |
| Appendix | |
| Appendix 1: Reference Sheet of Celsius and Fahrenheit..... | 96 |
| Appendix 2: Pipe Expanding Method..... | 97 |
| Appendix 3: List of Resistance for Temperature Sensor..... | 98 |

1. Summary

Outdoor Unit:

MV-E14BI2
MV-E18BI2



MV-E21BI2
MV-E24BI2
MV-E28BI2

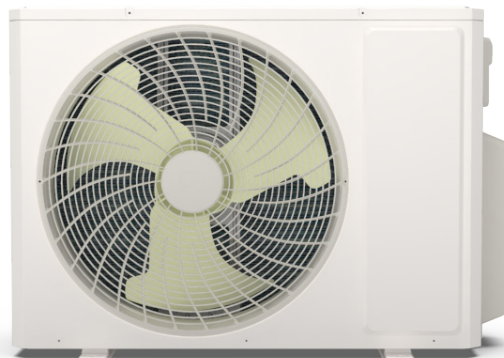

MV-E36BI2
MV-E42BI2

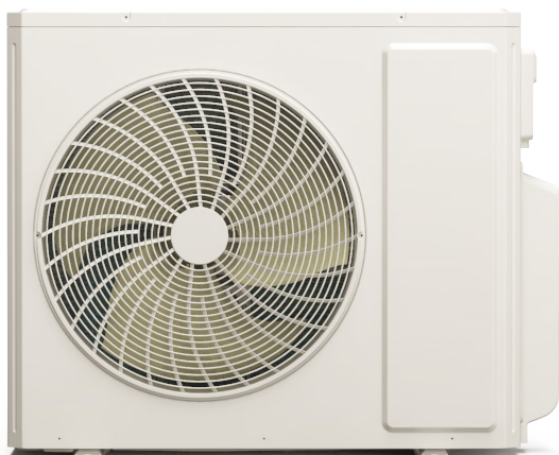

Model list:

| No | Model | Product code |
|----|-----------|--------------|
| 1 | MV-E14BI2 | CB228W14300 |
| 2 | MV-E18BI2 | CB228W14500 |
| 3 | MV-E21BI2 | CB228W14400 |
| 4 | MV-E24BI2 | CB228W14600 |
| 5 | MV-E28BI2 | CB228W14800 |
| 6 | MV-E36BI2 | CB228W14700 |
| 7 | MV-E42BI2 | CB228W14900 |

2. Specifications

| Model | | | MV-E14BI2 | |
|-----------------------|---|-----|---------------------------------|-----------------------------|
| | | | CB228W14300 | |
| Power Supply | Rated Voltage | V~ | 220-240 | |
| | Rated Frequency | Hz | 50 | |
| | Phases | | 1 | |
| Cooling Capacity | | W | 4.1 | |
| Heating Capacity | | W | 4.4 | |
| Cooling Power Input | | W | 1.1 | |
| Heating Power Input | | W | 0.97 | |
| Cooling Current Input | | A | 4.88 | |
| Heating Current Input | | A | 4.44 | |
| Rated Power Input | | W | 2.25 | |
| Rated Current | | A | 10 | |
| EER | | W/W | 3.73 | |
| COP | | W/W | 4.54 | |
| Outdoor Unit | Compressor Trademark | | ZHUHAI LANDA COMPRESSOR CO.,LTD | |
| | Compressor Model | | QXF-A120zH170A | |
| | Compressor Refrigerant Oil Type | | FW68DA | |
| | Compressor Type | | Inverter Rotary | |
| | L.R.A | | A | 25 |
| | Compressor Rated Load Amp (RLA) | | A | / |
| | Compressor Power Input | | W | 1096 |
| | Compressor Thermal Protector | | | KSD115°C HPC115/95U1 |
| | Throttling Method | | | Electron expansion valve |
| | Cooling Operation Ambient Temperature Range | | °C | -15~43 |
| | Heating Operation Ambient Temperature Range | | °C | -22~24 |
| | Condenser Material | | | Aluminum Fin-copper Tube |
| | Condenser Pipe Diameter | | mm | Φ7.94 |
| | Rows-Fin Gap(mm) | | mm | 1-1.2 |
| | Coil length (L) X Height (H) X Coil width (W) | | mm | 834×528×19.05 |
| | Fan Motor Speed (rpm) (H/M/L) | | rpm | Cooling: 800 / Heating: 860 |
| | Output of Fan Motor | | W | 30 |
| | Fan Motor RLA | | A | 0.4 |
| | Fan Motor Capacitor | | μF | / |
| | Air Flow Volume of Outdoor Unit | | m ³ /h | 2300 |
| | Fan Type-Piece | | | Axial-flow |
| | Fan Diameter-Height | | mm | 420-131.1 |
| | Defrosting Method | | | Automatic Defrosting |
| | Climate Type | | | T1 |
| | Isolation | | | I |
| | Moisture Protection | | | IPX4 |
| | Permissible Excessive Operating Pressure for the Discharge Side | | MPa | 4.3 |
| | Permissible Excessive Operating Pressure for the Suction Side | | MPa | 2.5 |
| | Dimension (WDXH) | | mm | 822×352×550 |
| | Dimension of Carton Box (LXWXH) | | mm | 869×395×594 |
| | Dimension of Package (LXWXH) | | mm | 872×398×620 |
| | Net Weight | | kg | 30 |
| Gross Weight | | kg | 32.5 | |
| Refrigerant | | | R32 | |
| Refrigerant Charge | | kg | 0.75 | |

2. Specifications

| | | | |
|-----------------|--|-----------------|------------------|
| Outdoor Unit | Cross-sectional Area of Power Cable Conductor | mm ² | 1.5 |
| | Recommended Power Cable(Core) | N | 3 |
| | Connection Pipe Connection Method | | Flare Connection |
| | Not Additional Gas Connection Pipe Length | m | 10 |
| | Connection Pipe Gas Additional Charge | g/m | 20 |
| | Outer Diameter of Liquid Pipe1 | inch | 1/4 |
| | Outer Diameter of Gas Pipe1 | inch | 3/8 |
| | Outer Diameter of Liquid Pipe2 | inch | 1/4 |
| | Outer Diameter of Gas Pipe2 | inch | 3/8 |
| | Outer Diameter of Liquid Pipe3 | inch | / |
| | Outer Diameter of Gas Pipe3 | inch | / |
| | Outer Diameter of Liquid Pipe4 | inch | / |
| | Outer Diameter of Gas Pipe4 | inch | / |
| | Outer Diameter of Liquid Pipe5 | inch | / |
| | Outer Diameter of Gas Pipe5 | inch | / |
| | Connection Pipe Max. Height Distance (Indoor and Indoor) | m | 15 |
| | Max. equivalent connection pipe length | m | 20 |
| | Connection Pipe Max. Length Distance (total length) | m | 40 |

The above data is subject to change without notice; please refer to the nameplate of the unit.

2. Specifications

| Model | | | MV-E18BI2 | |
|------------------------------|---|-----|---------------------------------|-----------------------------|
| | | | CB228W14500 | |
| Power Supply | Rated Voltage | V~ | 220-240 | |
| | Rated Frequency | Hz | 50 | |
| | Phases | | 1 | |
| Cooling Capacity | | W | 5.3 | |
| Heating Capacity | | W | 5.65 | |
| Cooling Power Input | | W | 1.48 | |
| Heating Power Input | | W | 1.25 | |
| Cooling Current Input | | A | 6.56 | |
| Heating Current Input | | A | 5.55 | |
| Rated Power Input | | W | 2.5 | |
| Rated Current | | A | 11 | |
| EER | | W/W | 3.58 | |
| COP | | W/W | 4.52 | |
| Outdoor Unit | Compressor Trademark | | ZHUHAI LANDA COMPRESSOR CO.,LTD | |
| | Compressor Model | | QXF-A139zH170A | |
| | Compressor Refrigerant Oil Type | | FW68DA | |
| | Compressor Type | | Inverter Rotary | |
| | L.R.A | | A | 25 |
| | Compressor Rated Load Amp (RLA) | | A | / |
| | Compressor Power Input | | W | 1295 |
| | Compressor Thermal Protector | | | KSD115°C HPC115/95U1 |
| | Throttling Method | | | Electron expansion valve |
| | Cooling Operation Ambient Temperature Range | | °C | -15~43 |
| | Heating Operation Ambient Temperature Range | | °C | -22~24 |
| | Condenser Material | | | Aluminum Fin-copper Tube |
| | Condenser Pipe Diameter | | mm | Φ7 |
| | Rows-Fin Gap(mm) | | mm | 2-1.4 |
| | Coil length (L) X Height (H) X Coil width (W) | | mm | 834×528×38.1 |
| | Fan Motor Speed (rpm) (H/M/L) | | rpm | Cooling: 800 / Heating: 860 |
| | Output of Fan Motor | | W | 30 |
| | Fan Motor RLA | | A | 0.4 |
| | Fan Motor Capacitor | | μF | / |
| | Air Flow Volume of Outdoor Unit | | m ³ /h | 2300 |
| | Fan Type-Piece | | | Axial-flow |
| | Fan Diameter-Height | | mm | 420-131.1 |
| | Defrosting Method | | | Automatic Defrosting |
| | Climate Type | | | T1 |
| | Isolation | | | I |
| | Moisture Protection | | | IPX4 |
| | Permissible Excessive Operating Pressure for the Discharge Side | | MPa | 4.3 |
| | Permissible Excessive Operating Pressure for the Suction Side | | MPa | 2.5 |
| | Dimension (WXDXH) | | mm | 822×352×550 |
| | Dimension of Carton Box (LXWXH) | | mm | 869×395×594 |
| Dimension of Package (LXWXH) | | mm | 872×398×620 | |
| Net Weight | | kg | 32 | |
| Gross Weight | | kg | 34.5 | |
| Refrigerant | | | R32 | |
| Refrigerant Charge | | kg | 0.9 | |

2. Specifications

| | | | |
|-----------------|--|-----------------|------------------|
| Outdoor Unit | Cross-sectional Area of Power Cable Conductor | mm ² | 1.5 |
| | Recommended Power Cable(Core) | N | 3 |
| | Connection Pipe Connection Method | | Flare Connection |
| | Not Additional Gas Connection Pipe Length | m | 10 |
| | Connection Pipe Gas Additional Charge | g/m | 20 |
| | Outer Diameter of Liquid Pipe1 | inch | 1/4 |
| | Outer Diameter of Gas Pipe1 | inch | 3/8 |
| | Outer Diameter of Liquid Pipe2 | inch | 1/4 |
| | Outer Diameter of Gas Pipe2 | inch | 3/8 |
| | Outer Diameter of Liquid Pipe3 | inch | / |
| | Outer Diameter of Gas Pipe3 | inch | / |
| | Outer Diameter of Liquid Pipe4 | inch | / |
| | Outer Diameter of Gas Pipe4 | inch | / |
| | Outer Diameter of Liquid Pipe5 | inch | / |
| | Outer Diameter of Gas Pipe5 | inch | / |
| | Connection Pipe Max. Height Distance (Indoor and Indoor) | m | 15 |
| | Max. equivalent connection pipe length | m | 20 |
| | Connection Pipe Max. Length Distance (total length) | m | 40 |

The above data is subject to change without notice; please refer to the nameplate of the unit.

2. Specifications

| Model | | | MV-E21BI2 | |
|-----------------------|---|-----|-----------------------------------|-----------------------------|
| | | | CB228W14400 | |
| Power Supply | Rated Voltage | V~ | 220-240 | |
| | Rated Frequency | Hz | 50 | |
| | Phases | | 1 | |
| Cooling Capacity | | W | 6.1 | |
| Heating Capacity | | W | 6.5 | |
| Cooling Power Input | | W | 1.48 | |
| Heating Power Input | | W | 1.43 | |
| Cooling Current Input | | A | 6.57 | |
| Heating Current Input | | A | 6.34 | |
| Rated Power Input | | W | 2.9 | |
| Rated Current | | A | 12.9 | |
| EER | | W/W | 4.12 | |
| COP | | W/W | 4.55 | |
| Outdoor Unit | Compressor Trademark | | ZHUHAI LANDA COMPRESSOR CO., LTD. | |
| | Compressor Model | | FTz-SM151AXBD | |
| | Compressor Refrigerant Oil Type | | FW68DA or equivalent | |
| | Compressor Type | | Twin Rotary | |
| | L.R.A | | A | 18 |
| | Compressor Rated Load Amp (RLA) | | A | / |
| | Compressor Power Input | | W | 1330 |
| | Compressor Thermal Protector | | | KSD115°C HPC115/95U1 |
| | Throttling Method | | | Electron expansion valve |
| | Cooling Operation Ambient Temperature Range | | °C | -15~43 |
| | Heating Operation Ambient Temperature Range | | °C | -22~24 |
| | Condenser Material | | | Aluminum Fin-copper Tube |
| | Condenser Pipe Diameter | | mm | Φ7 |
| | Rows-Fin Gap(mm) | | mm | 2-1.4 |
| | Coil length (L) X Height (H) X Coil width (W) | | mm | 851×616×38.1 |
| | Fan Motor Speed (rpm) (H/M/L) | | rpm | Cooling: 850 / Heating: 800 |
| | Output of Fan Motor | | W | 60 |
| | Fan Motor RLA | | A | 0.426 |
| | Fan Motor Capacitor | | μF | / |
| | Air Flow Volume of Outdoor Unit | | m ³ /h | 3800 |
| | Fan Type-Piece | | | Axial-flow |
| | Fan Diameter-Height | | mm | 520-154 |
| | Defrosting Method | | | Automatic Defrosting |
| | Climate Type | | | T1 |
| | Isolation | | | I |
| | Moisture Protection | | | IPX4 |
| | Permissible Excessive Operating Pressure for the Discharge Side | | MPa | 4.3 |
| | Permissible Excessive Operating Pressure for the Suction Side | | MPa | 2.5 |
| | Dimension (WXDXH) | | mm | 964×402×660 |
| | Dimension of Carton Box (LXWXH) | | mm | 1029×453×715 |
| | Dimension of Package (LXWXH) | | mm | 1032×456×737 |
| Net Weight | | kg | 47.5 | |
| Gross Weight | | kg | 52 | |
| Refrigerant | | | R32 | |
| Refrigerant Charge | | kg | 1.6 | |

2. Specifications

| | | | |
|-----------------|--|-----------------|------------------|
| Outdoor Unit | Cross-sectional Area of Power Cable Conductor | mm ² | 2.5 |
| | Recommended Power Cable(Core) | N | 3 |
| | Connection Pipe Connection Method | | Flare Connection |
| | Not Additional Gas Connection Pipe Length | m | 30 |
| | Connection Pipe Gas Additional Charge | g/m | 20 |
| | Outer Diameter of Liquid Pipe1 | inch | 1/4 |
| | Outer Diameter of Gas Pipe1 | inch | 3/8 |
| | Outer Diameter of Liquid Pipe2 | inch | 1/4 |
| | Outer Diameter of Gas Pipe2 | inch | 3/8 |
| | Outer Diameter of Liquid Pipe3 | inch | 1/4 |
| | Outer Diameter of Gas Pipe3 | inch | 3/8 |
| | Outer Diameter of Liquid Pipe4 | inch | / |
| | Outer Diameter of Gas Pipe4 | inch | / |
| | Outer Diameter of Liquid Pipe5 | inch | / |
| | Outer Diameter of Gas Pipe5 | inch | / |
| | Connection Pipe Max. Height Distance (Indoor and Indoor) | m | 15 |
| | Max. equivalent connection pipe length | m | 20 |
| | Connection Pipe Max. Length Distance (total length) | m | 60 |

The above data is subject to change without notice; please refer to the nameplate of the unit.

2. Specifications

| Model | | | MV-E24BI2 | |
|------------------------------|---|-----|-----------------------------------|-----------------------------|
| | | | CB228W14600 | |
| Power Supply | Rated Voltage | V~ | 220-240 | |
| | Rated Frequency | Hz | 50 | |
| | Phases | | 1 | |
| Cooling Capacity | | W | 7.1 | |
| Heating Capacity | | W | 8.6 | |
| Cooling Power Input | | W | 1.88 | |
| Heating Power Input | | W | 2.23 | |
| Cooling Current Input | | A | 8.34 | |
| Heating Current Input | | A | 9.89 | |
| Rated Power Input | | W | Cooling: 3.4 / Heating: 3.0 | |
| Rated Current | | A | Cooling: 15 / Heating: 14.6 | |
| EER | | W/W | 3.78 | |
| COP | | W/W | 3.86 | |
| Outdoor Unit | Compressor Trademark | | ZHUHAI LANDA COMPRESSOR CO., LTD. | |
| | Compressor Model | | QXFS-M180zX170 | |
| | Compressor Refrigerant Oil Type | | FW68DA or equivalent | |
| | Compressor Type | | Twin Rotary | |
| | L.R.A | | A | 24 |
| | Compressor Rated Load Amp (RLA) | | A | / |
| | Compressor Power Input | | W | 1480 |
| | Compressor Thermal Protector | | | HPC115/95/KSD115°C |
| | Throttling Method | | | Electron expansion valve |
| | Cooling Operation Ambient Temperature Range | | °C | -15~43 |
| | Heating Operation Ambient Temperature Range | | °C | -22~24 |
| | Condenser Material | | | Aluminum Fin-copper Tube |
| | Condenser Pipe Diameter | | mm | Φ7 |
| | Rows-Fin Gap(mm) | | mm | 2-1.4 |
| | Coil length (L) X Height (H) X Coil width (W) | | mm | 851×616×38.1 |
| | Fan Motor Speed (rpm) (H/M/L) | | rpm | Cooling: 850 / Heating: 800 |
| | Output of Fan Motor | | W | 60 |
| | Fan Motor RLA | | A | 0.426 |
| | Fan Motor Capacitor | | μF | / |
| | Air Flow Volume of Outdoor Unit | | m ³ /h | 3800 |
| | Fan Type-Piece | | | Axial-flow |
| | Fan Diameter-Height | | mm | 520-154 |
| | Defrosting Method | | | Automatic Defrosting |
| | Climate Type | | | T1 |
| | Isolation | | | I |
| | Moisture Protection | | | IPX4 |
| | Permissible Excessive Operating Pressure for the Discharge Side | | MPa | 4.3 |
| | Permissible Excessive Operating Pressure for the Suction Side | | MPa | 2.5 |
| | Dimension (WXDXH) | | mm | 964×402×660 |
| | Dimension of Carton Box (LXWXH) | | mm | 1029×453×715 |
| Dimension of Package (LXWXH) | | mm | 1032×456×737 | |
| Net Weight | | kg | 47.5 | |
| Gross Weight | | kg | 52 | |
| Refrigerant | | | R32 | |
| Refrigerant Charge | | kg | 1.7 | |

2. Specifications

| | | | |
|-----------------|--|-----------------|------------------|
| Outdoor Unit | Cross-sectional Area of Power Cable Conductor | mm ² | 2.5 |
| | Recommended Power Cable(Core) | N | 3 |
| | Connection Pipe Connection Method | | Flare Connection |
| | Not Additional Gas Connection Pipe Length | m | 30 |
| | Connection Pipe Gas Additional Charge | g/m | 20 |
| | Outer Diameter of Liquid Pipe1 | inch | 1/4 |
| | Outer Diameter of Gas Pipe1 | inch | 3/8 |
| | Outer Diameter of Liquid Pipe2 | inch | 1/4 |
| | Outer Diameter of Gas Pipe2 | inch | 3/8 |
| | Outer Diameter of Liquid Pipe3 | inch | 1/4 |
| | Outer Diameter of Gas Pipe3 | inch | 3/8 |
| | Outer Diameter of Liquid Pipe4 | inch | / |
| | Outer Diameter of Gas Pipe4 | inch | / |
| | Outer Diameter of Liquid Pipe5 | inch | / |
| | Outer Diameter of Gas Pipe5 | inch | / |
| | Connection Pipe Max. Height Distance (Indoor and Indoor) | m | 15 |
| | Max. equivalent connection pipe length | m | 20 |
| | Connection Pipe Max. Length Distance (total length) | m | 60 |

The above data is subject to change without notice; please refer to the nameplate of the unit.

2. Specifications

| Model | | | MV-E28BI2 | |
|-----------------------|---|-----|-----------------------------------|-----------------------------|
| | | | CB228W14800 | |
| Power Supply | Rated Voltage | V~ | 220-240 | |
| | Rated Frequency | Hz | 50 | |
| | Phases | | 1 | |
| Cooling Capacity | | W | 8 | |
| Heating Capacity | | W | 9.5 | |
| Cooling Power Input | | W | 2.12 | |
| Heating Power Input | | W | 2.2 | |
| Cooling Current Input | | A | 9.41 | |
| Heating Current Input | | A | 9.76 | |
| Rated Power Input | | W | 3.6 | |
| Rated Current | | A | 15.97 | |
| EER | | W/W | 3.77 | |
| COP | | W/W | 4.32 | |
| Outdoor Unit | Compressor Trademark | | ZHUHAI LANDA COMPRESSOR CO., LTD. | |
| | Compressor Model | | QXFS-B212zX070 | |
| | Compressor Refrigerant Oil Type | | FW68DA or equivalent | |
| | Compressor Type | | Twin Rotary | |
| | L.R.A | | A | 35 |
| | Compressor Rated Load Amp (RLA) | | A | / |
| | Compressor Power Input | | W | 1887 |
| | Compressor Thermal Protector | | | KSD115°C HPC115/95U1 |
| | Throttling Method | | | Electron expansion valve |
| | Cooling Operation Ambient Temperature Range | | °C | -15~43 |
| | Heating Operation Ambient Temperature Range | | °C | -22~24 |
| | Condenser Material | | | Aluminum Fin-copper Tube |
| | Condenser Pipe Diameter | | mm | Φ7.94 |
| | Rows-Fin Gap(mm) | | mm | 2-1.4 |
| | Coil length (L) X Height (H) X Coil width (W) | | mm | 851×616×38.1 |
| | Fan Motor Speed (rpm) (H/M/L) | | rpm | Cooling: 850 / Heating: 800 |
| | Output of Fan Motor | | W | 60 |
| | Fan Motor RLA | | A | 0.426 |
| | Fan Motor Capacitor | | μF | / |
| | Air Flow Volume of Outdoor Unit | | m ³ /h | 3800 |
| | Fan Type-Piece | | | Axial-flow |
| | Fan Diameter-Height | | mm | 520-154 |
| | Defrosting Method | | | Automatic Defrosting |
| | Climate Type | | | T1 |
| | Isolation | | | I |
| | Moisture Protection | | | IPX4 |
| | Permissible Excessive Operating Pressure for the Discharge Side | | MPa | 4.3 |
| | Permissible Excessive Operating Pressure for the Suction Side | | MPa | 2.5 |
| | Dimension (WXDXH) | | mm | 964×402×660 |
| | Dimension of Carton Box (LXWXH) | | mm | 1029×453×715 |
| | Dimension of Package (LXWXH) | | mm | 1032×456×737 |
| | Net Weight | | kg | 51 |
| Gross Weight | | kg | 55.5 | |
| Refrigerant | | | R32 | |
| Refrigerant Charge | | kg | 1.8 | |

2. Specifications

| | | | |
|-----------------|--|-----------------|------------------|
| Outdoor Unit | Cross-sectional Area of Power Cable Conductor | mm ² | 2.5 |
| | Recommended Power Cable(Core) | N | 3 |
| | Connection Pipe Connection Method | | Flare Connection |
| | Not Additional Gas Connection Pipe Length | m | 40 |
| | Connection Pipe Gas Additional Charge | g/m | 20 |
| | Outer Diameter of Liquid Pipe1 | inch | 1/4 |
| | Outer Diameter of Gas Pipe1 | inch | 3/8 |
| | Outer Diameter of Liquid Pipe2 | inch | 1/4 |
| | Outer Diameter of Gas Pipe2 | inch | 3/8 |
| | Outer Diameter of Liquid Pipe3 | inch | 1/4 |
| | Outer Diameter of Gas Pipe3 | inch | 3/8 |
| | Outer Diameter of Liquid Pipe4 | inch | 1/4 |
| | Outer Diameter of Gas Pipe4 | inch | 3/8 |
| | Outer Diameter of Liquid Pipe5 | inch | / |
| | Outer Diameter of Gas Pipe5 | inch | / |
| | Connection Pipe Max. Height Distance (Indoor and Indoor) | m | 15 |
| | Max. equivalent connection pipe length | m | 20 |
| | Connection Pipe Max. Length Distance (total length) | m | 70 |

The above data is subject to change without notice; please refer to the nameplate of the unit.

2. Specifications

| Model | | | MV-E36BI2 | |
|------------------------------|---|-----|-----------------------------------|-----------------------------|
| | | | CB228W14700 | |
| Power Supply | Rated Voltage | V~ | 220-240 | |
| | Rated Frequency | Hz | 50 | |
| | Phases | | 1 | |
| Cooling Capacity | | W | 10.6 | |
| Heating Capacity | | W | 12 | |
| Cooling Power Input | | W | 3 | |
| Heating Power Input | | W | 3.04 | |
| Cooling Current Input | | A | 13.31 | |
| Heating Current Input | | A | 13.49 | |
| Rated Power Input | | W | Cooling: 4.6 / Heating: 5.0 | |
| Rated Current | | A | Cooling: 20.41 / Heating: 21.74 | |
| EER | | W/W | 3.53 | |
| COP | | W/W | 3.95 | |
| Outdoor Unit | Compressor Trademark | | ZHUHAI LANDA COMPRESSOR CO., LTD. | |
| | Compressor Model | | QXFS-D280zX070C | |
| | Compressor Refrigerant Oil Type | | FW68DA or equivalent | |
| | Compressor Type | | Twin Rotary | |
| | L.R.A | | A | 40 |
| | Compressor Rated Load Amp (RLA) | | A | / |
| | Compressor Power Input | | W | 2294 |
| | Compressor Thermal Protector | | | KSD115°C HPC115/95U1 |
| | Throttling Method | | | Electron expansion valve |
| | Cooling Operation Ambient Temperature Range | | °C | -15~43 |
| | Heating Operation Ambient Temperature Range | | °C | -22~24 |
| | Condenser Material | | | Aluminum Fin-copper Tube |
| | Condenser Pipe Diameter | | mm | Φ7.94 |
| | Rows-Fin Gap(mm) | | mm | 2-1.4 |
| | Coil length (L) X Height (H) X Coil width (W) | | mm | 1066×792×38.1 |
| | Fan Motor Speed (rpm) (H/M/L) | | rpm | Cooling: 800 / Heating: 860 |
| | Output of Fan Motor | | W | 130 |
| | Fan Motor RLA | | A | / |
| | Fan Motor Capacitor | | μF | / |
| | Air Flow Volume of Outdoor Unit | | m ³ /h | 5800 |
| | Fan Type-Piece | | | Axial-flow |
| | Fan Diameter-Height | | mm | 550-205 |
| | Defrosting Method | | | Automatic Defrosting |
| | Climate Type | | | T1 |
| | Isolation | | | I |
| | Moisture Protection | | | IPX4 |
| | Permissible Excessive Operating Pressure for the Discharge Side | | MPa | 4.3 |
| | Permissible Excessive Operating Pressure for the Suction Side | | MPa | 2.5 |
| | Dimension (WXDXH) | | mm | 1020×427×826 |
| | Dimension of Carton Box (LXWXH) | | mm | 1090×494×870 |
| Dimension of Package (LXWXH) | | mm | 1093×497×885 | |
| Net Weight | | kg | 72 | |
| Gross Weight | | kg | 79 | |
| Refrigerant | | | R32 | |
| Refrigerant Charge | | kg | 2.4 | |

2. Specifications

| | | | |
|-----------------|--|-----------------|------------------|
| Outdoor Unit | Cross-sectional Area of Power Cable Conductor | mm ² | 4 |
| | Recommended Power Cable(Core) | N | 3 |
| | Connection Pipe Connection Method | | Flare Connection |
| | Not Additional Gas Connection Pipe Length | m | 40 |
| | Connection Pipe Gas Additional Charge | g/m | 20 |
| | Outer Diameter of Liquid Pipe1 | inch | 1/4 |
| | Outer Diameter of Gas Pipe1 | inch | 3/8 |
| | Outer Diameter of Liquid Pipe2 | inch | 1/4 |
| | Outer Diameter of Gas Pipe2 | inch | 3/8 |
| | Outer Diameter of Liquid Pipe3 | inch | 1/4 |
| | Outer Diameter of Gas Pipe3 | inch | 3/8 |
| | Outer Diameter of Liquid Pipe4 | inch | 1/4 |
| | Outer Diameter of Gas Pipe4 | inch | 3/8 |
| | Outer Diameter of Liquid Pipe5 | inch | / |
| | Outer Diameter of Gas Pipe5 | inch | / |
| | Connection Pipe Max. Height Distance (Indoor and Indoor) | m | 25 |
| | Max. equivalent connection pipe length | m | 25 |
| | Connection Pipe Max. Length Distance (total length) | m | 80 |

The above data is subject to change without notice; please refer to the nameplate of the unit.

2. Specifications

| Model | | | MV-E42BI2 | |
|-----------------------|---|-----|-----------------------------------|-----------------------------|
| | | | CB228W14900 | |
| Power Supply | Rated Voltage | V~ | 220-240 | |
| | Rated Frequency | Hz | 50 | |
| | Phases | | 1 | |
| Cooling Capacity | | W | 12.1 | |
| Heating Capacity | | W | 13 | |
| Cooling Power Input | | W | 3.4 | |
| Heating Power Input | | W | 3.19 | |
| Cooling Current Input | | A | 15.08 | |
| Heating Current Input | | A | 14.15 | |
| Rated Power Input | | W | Cooling: 4.6 / Heating: 5.0 | |
| Rated Current | | A | Cooling: 20.41 / Heating: 21.74 | |
| EER | | W/W | 3.56 | |
| COP | | W/W | 4.08 | |
| Outdoor Unit | Compressor Trademark | | ZHUHAI LANDA COMPRESSOR CO., LTD. | |
| | Compressor Model | | QXFS-D280zX070C | |
| | Compressor Refrigerant Oil Type | | FW68DA or equivalent | |
| | Compressor Type | | Twin Rotary | |
| | L.R.A | | A | 40 |
| | Compressor Rated Load Amp (RLA) | | A | / |
| | Compressor Power Input | | W | 2294 |
| | Compressor Thermal Protector | | | KSD115°C HPC115/95U1 |
| | Throttling Method | | | Electron expansion valve |
| | Cooling Operation Ambient Temperature Range | | °C | -15~43 |
| | Heating Operation Ambient Temperature Range | | °C | -22~24 |
| | Condenser Material | | | Aluminum Fin-copper Tube |
| | Condenser Pipe Diameter | | mm | Φ7.94 |
| | Rows-Fin Gap(mm) | | mm | 2-1.4 |
| | Coil length (L) X Height (H) X Coil width (W) | | mm | 1066×792×38.1 |
| | Fan Motor Speed (rpm) (H/M/L) | | rpm | Cooling: 800 / Heating: 860 |
| | Output of Fan Motor | | W | 130 |
| | Fan Motor RLA | | A | / |
| | Fan Motor Capacitor | | μF | / |
| | Air Flow Volume of Outdoor Unit | | m ³ /h | 5800 |
| | Fan Type-Piece | | | Axial-flow |
| | Fan Diameter-Height | | mm | 550-205 |
| | Defrosting Method | | | Automatic Defrosting |
| | Climate Type | | | T1 |
| | Isolation | | | I |
| | Moisture Protection | | | IPX4 |
| | Permissible Excessive Operating Pressure for the Discharge Side | | MPa | 4.3 |
| | Permissible Excessive Operating Pressure for the Suction Side | | MPa | 2.5 |
| | Dimension (WDXH) | | mm | 1020×427×826 |
| | Dimension of Carton Box (LXWXH) | | mm | 1090×494×870 |
| | Dimension of Package (LXWXH) | | mm | 1093×497×885 |
| Net Weight | | kg | 73 | |
| Gross Weight | | kg | 80 | |
| Refrigerant | | | R32 | |
| Refrigerant Charge | | kg | 2.4 | |

2. Specifications

| | | | |
|-----------------|--|-----------------|------------------|
| Outdoor Unit | Cross-sectional Area of Power Cable Conductor | mm ² | 4 |
| | Recommended Power Cable(Core) | N | 3 |
| | Connection Pipe Connection Method | | Flare Connection |
| | Not Additional Gas Connection Pipe Length | m | 50 |
| | Connection Pipe Gas Additional Charge | g/m | 20 |
| | Outer Diameter of Liquid Pipe1 | inch | 1/4 |
| | Outer Diameter of Gas Pipe1 | inch | 3/8 |
| | Outer Diameter of Liquid Pipe2 | inch | 1/4 |
| | Outer Diameter of Gas Pipe2 | inch | 3/8 |
| | Outer Diameter of Liquid Pipe3 | inch | 1/4 |
| | Outer Diameter of Gas Pipe3 | inch | 3/8 |
| | Outer Diameter of Liquid Pipe4 | inch | 1/4 |
| | Outer Diameter of Gas Pipe4 | inch | 3/8 |
| | Outer Diameter of Liquid Pipe5 | inch | 1/4 |
| | Outer Diameter of Gas Pipe5 | inch | 3/8 |
| | Connection Pipe Max. Height Distance (Indoor and Indoor) | m | 25 |
| | Max. equivalent connection pipe length | m | 25 |
| | Connection Pipe Max. Length Distance (total length) | m | 100 |

The above data is subject to change without notice; please refer to the nameplate of the unit.

Capacity Charts

Cooling

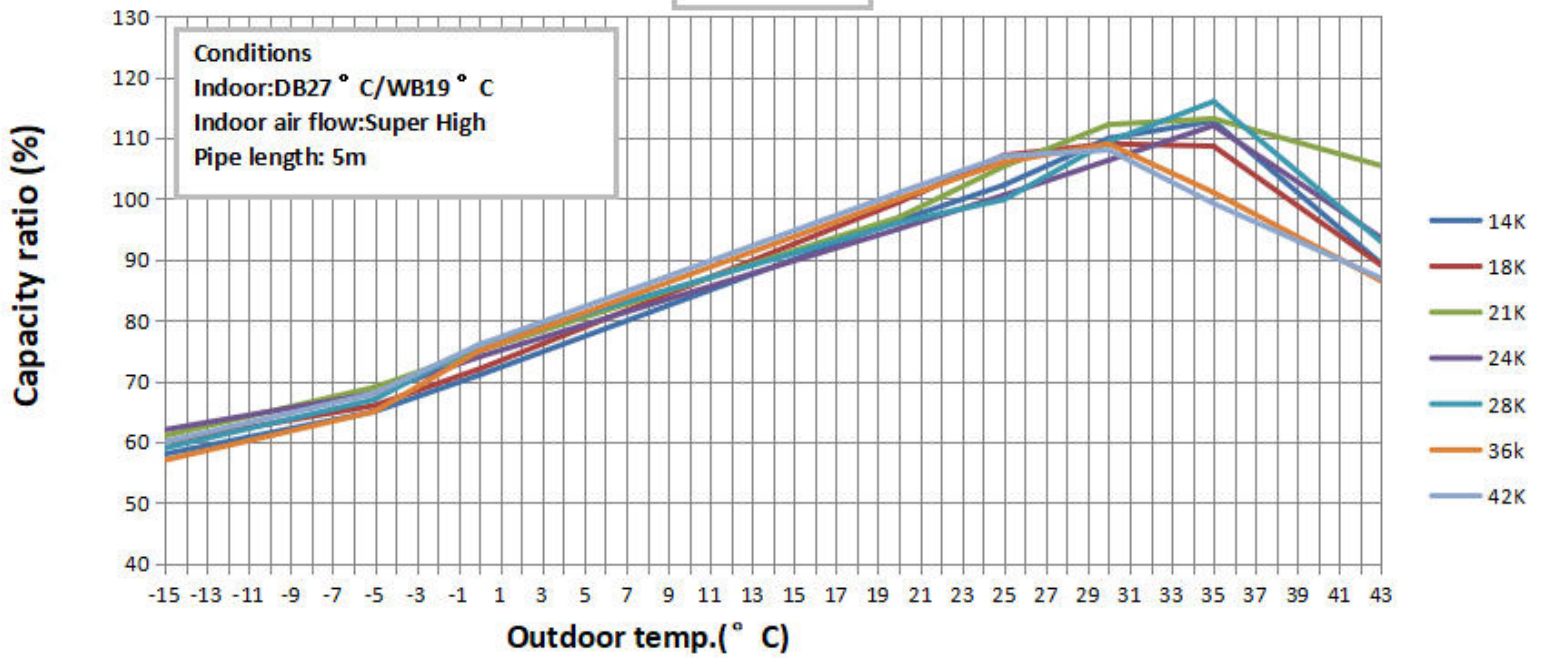

Heating

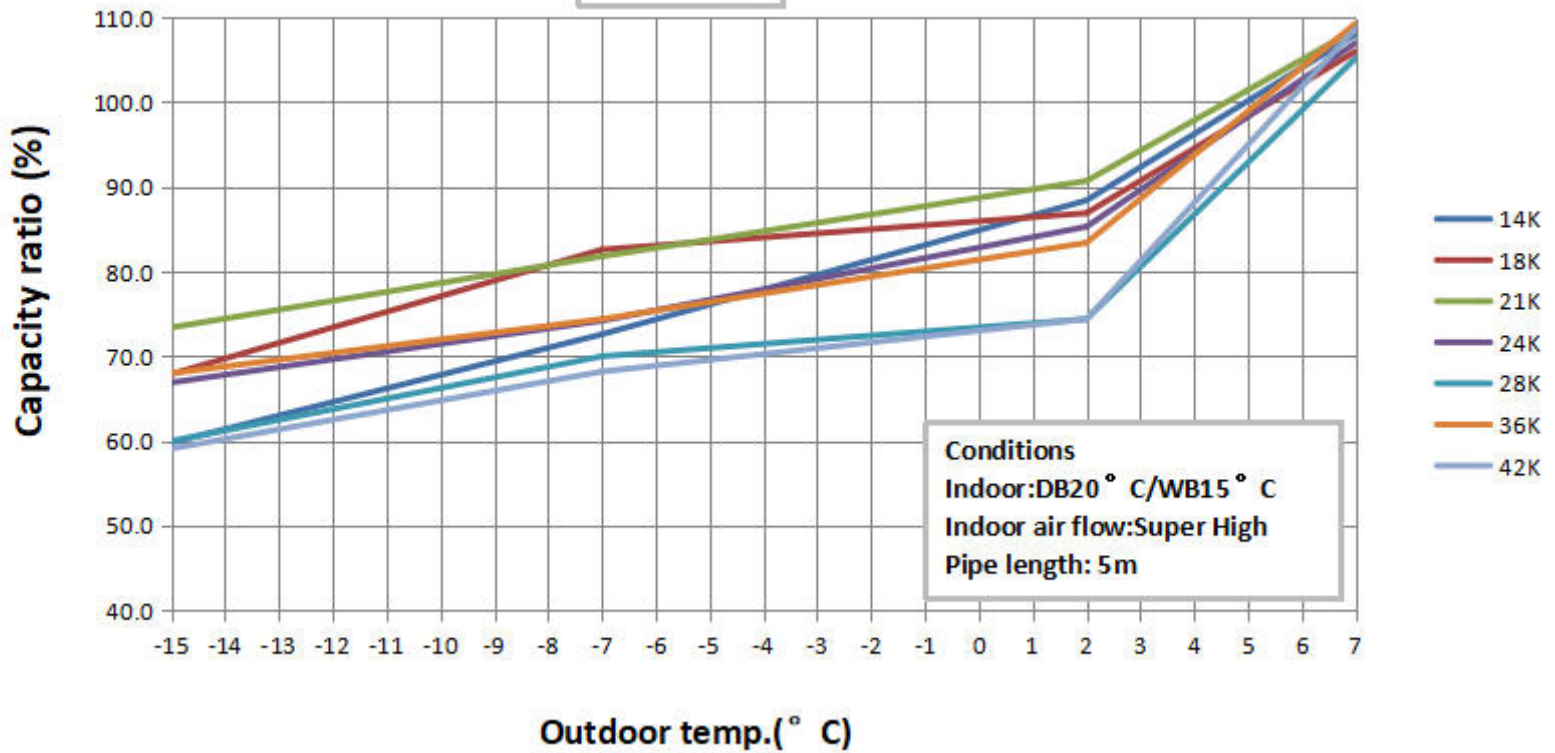

3. Outline Dimension Diagram

MV-E14BI2
MV-E18BI2

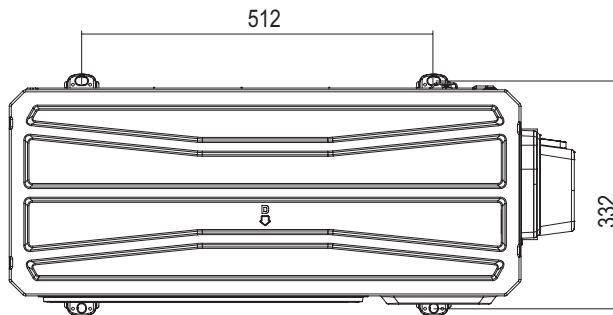
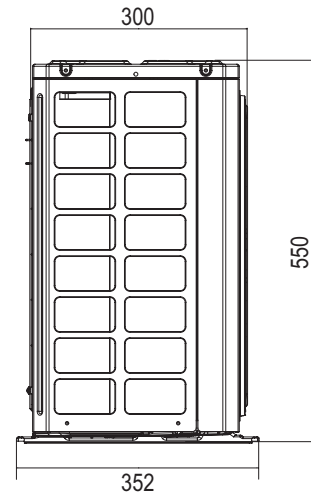
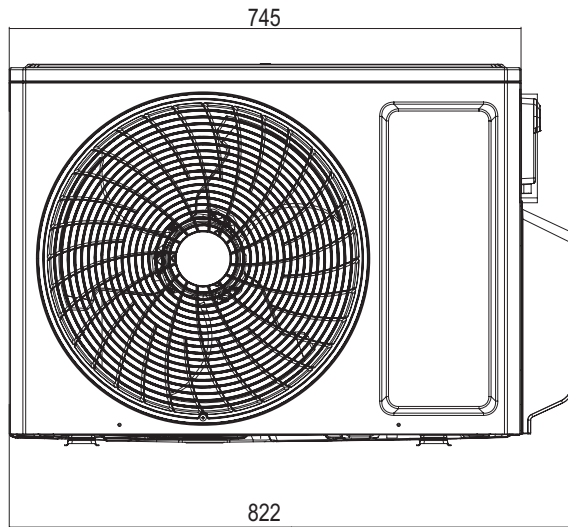

Unit:mm

MV-E21BI2
MV-E24BI2
MV-E28BI2

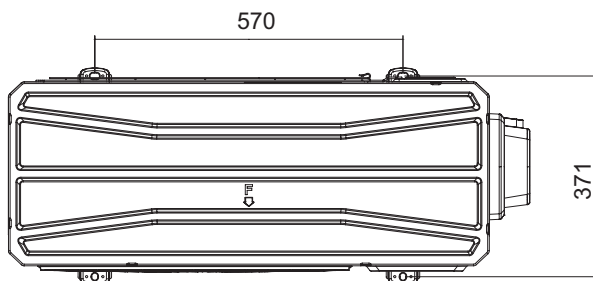
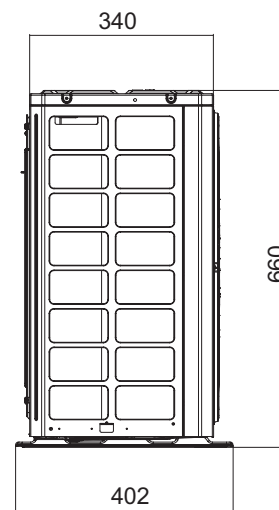
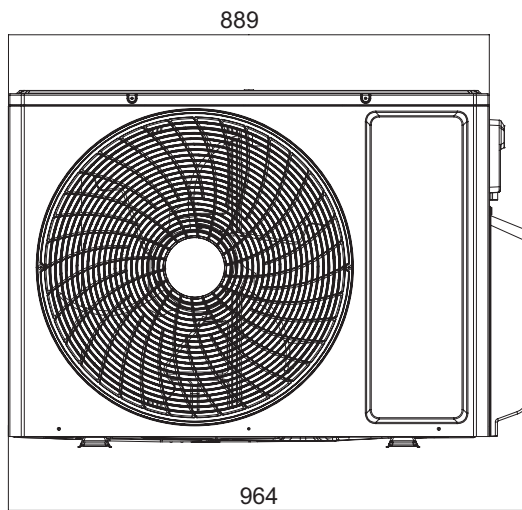

Unit:mm

3. Outline Dimension Diagram

MV-E36BI2
MV-E42BI2

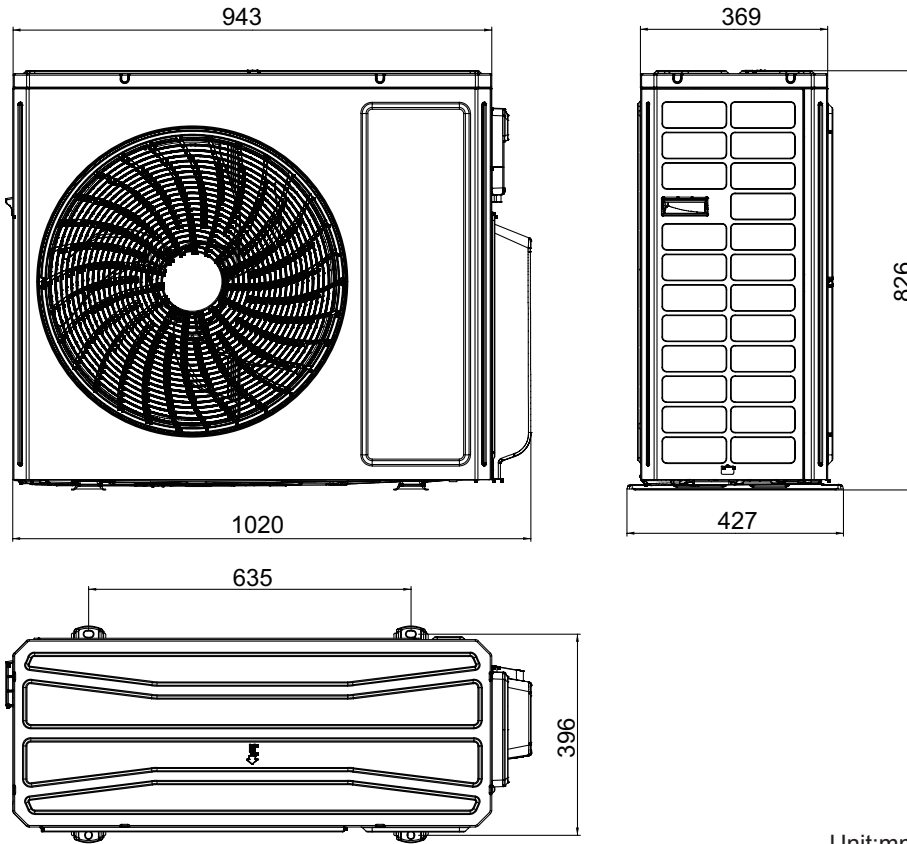

Unit:mm

4. Refrigerant System Diagram

MV-E14BI2
MV-E18BI2

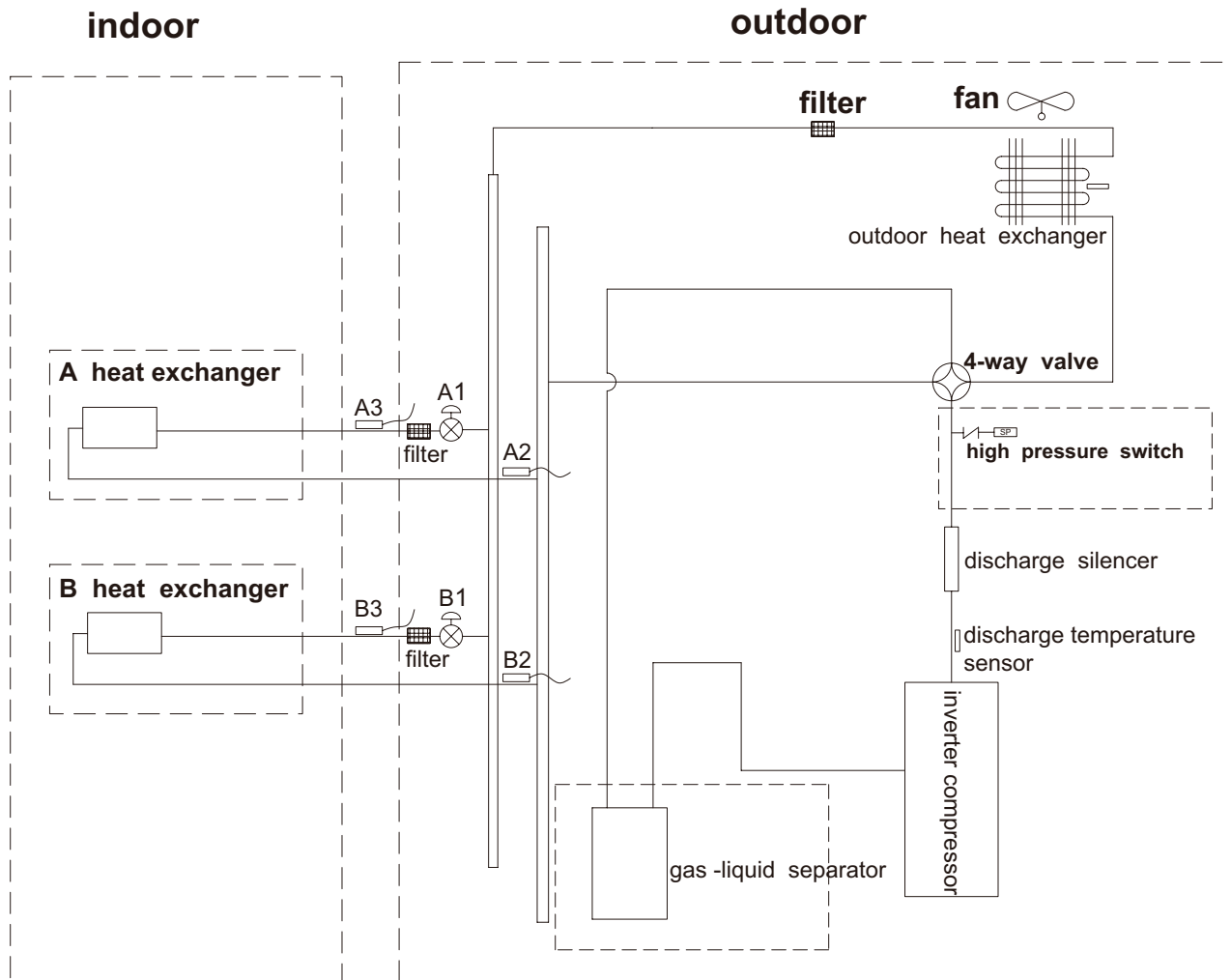

A1: A-unit electronic expansion valve
B1: B-unit electronic expansion valve

A2: A-unit gas pipe temperature sensor
B2: B-unit gas pipe temperature sensor

A3: A-unit liquid pipe temperature sensor
B3: B-unit liquid pipe temperature sensor

4. Refrigerant System Diagram

MV-E21BI2
MV-E24BI2

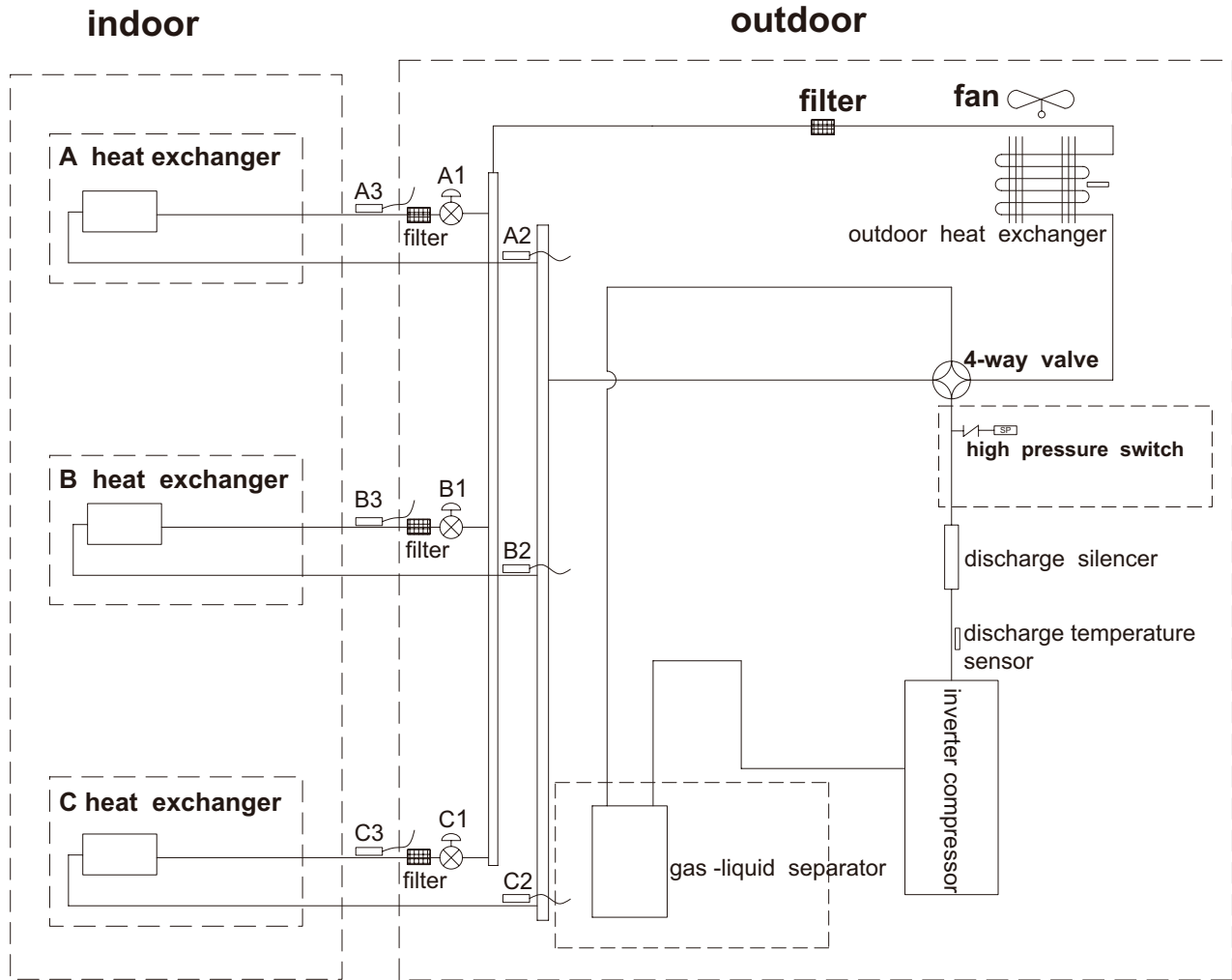

A1: A-unit electronic expansion valve
B1: B-unit electronic expansion valve
C1: C-unit electronic expansion valve

A2: A-unit gas pipe temperature sensor
B2: B-unit gas pipe temperature sensor
C2: C-unit gas pipe temperature sensor

A3: A-unit liquid pipe temperature sensor
B3: B-unit liquid pipe temperature sensor
C3: C-unit liquid pipe temperature sensor

4. Refrigerant System Diagram

MV-E28BI2
MV-E36BI2

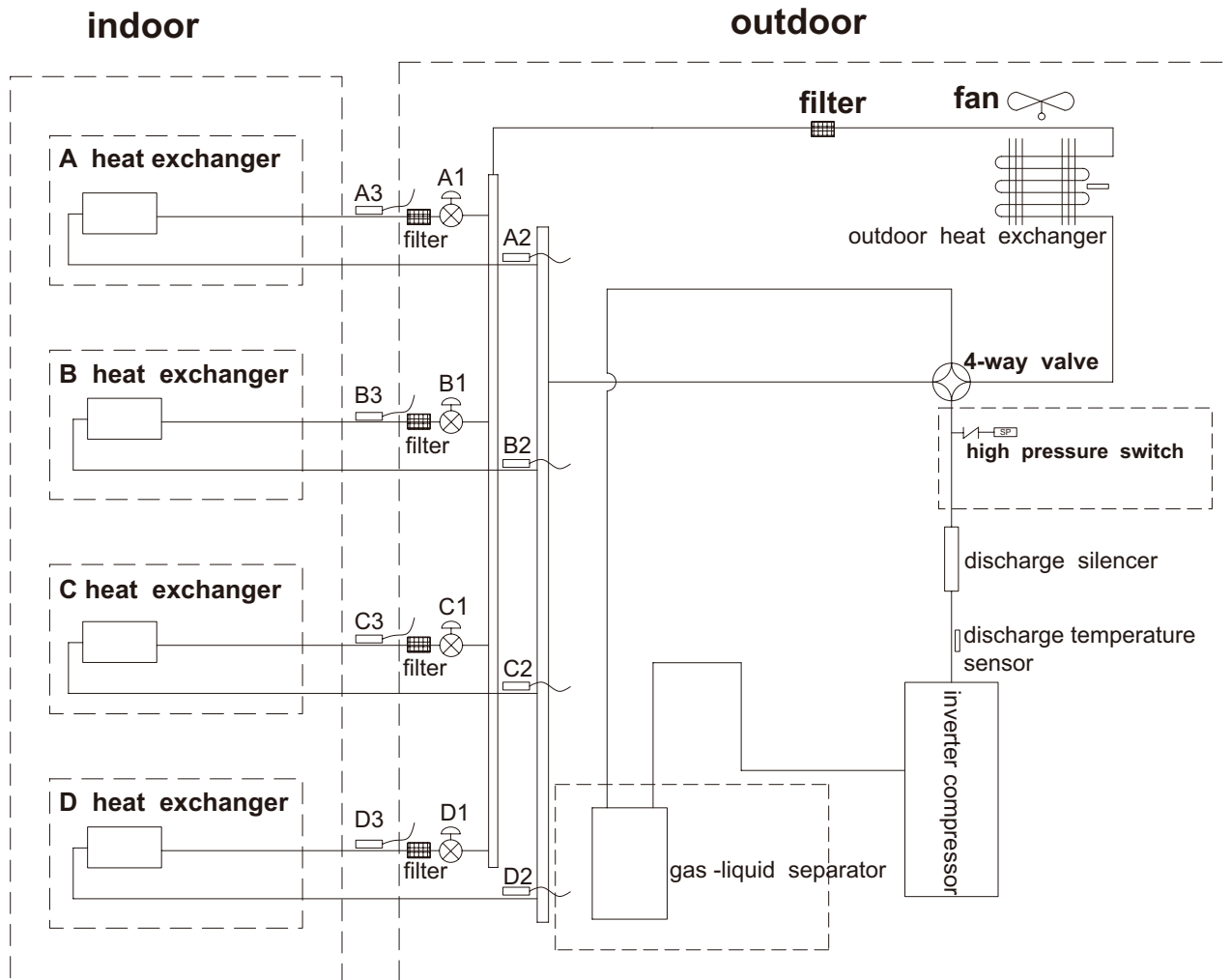

A1: A-unit electronic expansion valve
B1: B-unit electronic expansion valve
C1: C-unit electronic expansion valve
D1: D-unit electronic expansion valve

A2: A-unit gas pipe temperature sensor
B2: B-unit gas pipe temperature sensor
C2: C-unit gas pipe temperature sensor
D2: D-unit gas pipe temperature sensor

A3: A-unit liquid pipe temperature sensor
B3: B-unit liquid pipe temperature sensor
C3: C-unit liquid pipe temperature sensor
D3: D-unit liquid pipe temperature sensor

4. Refrigerant System Diagram

MV-E42BI2

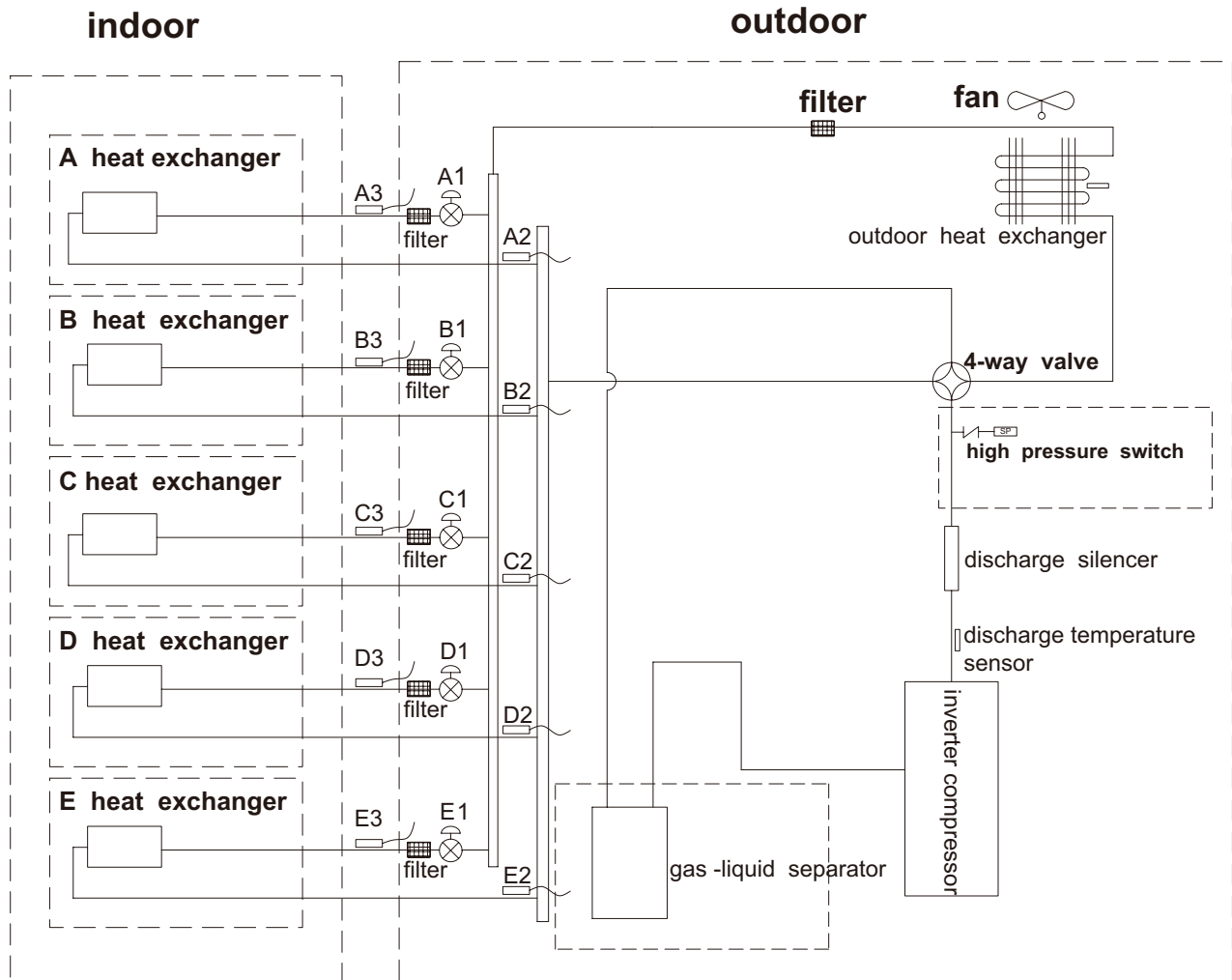

A1: A-unit electronic expansion valve
 B1: B-unit electronic expansion valve
 C1: C-unit electronic expansion valve
 D1: D-unit electronic expansion valve
 E1: E-unit electronic expansion valve

A2: A-unit gas pipe temperature sensor
 B2: B-unit gas pipe temperature sensor
 C2: C-unit gas pipe temperature sensor
 D2: D-unit gas pipe temperature sensor
 E2: E-unit gas pipe temperature sensor

A3: A-unit liquid pipe temperature sensor
 B3: B-unit liquid pipe temperature sensor
 C3: C-unit liquid pipe temperature sensor
 D3: D-unit liquid pipe temperature sensor
 E3: E-unit liquid pipe temperature sensor

5. Electrical Part

5.1 Wiring Diagram

• Instruction

| Symbol | Symbol Color | Symbol | Symbol Color | Symbol | Name |
|--------|--------------|--------|--------------|--------|----------------|
| WH | White | GN | Green | COMP | Compressor |
| YE | Yellow | BN | Brown | | Grounding wire |
| RD | Red | BU | Blue | / | / |
| YEGN | Yellow/Green | BK | Black | / | / |
| VT | Violet | OG | Orange | / | / |

• Outdoor Unit

MV-E14BI2
MV-E18BI2

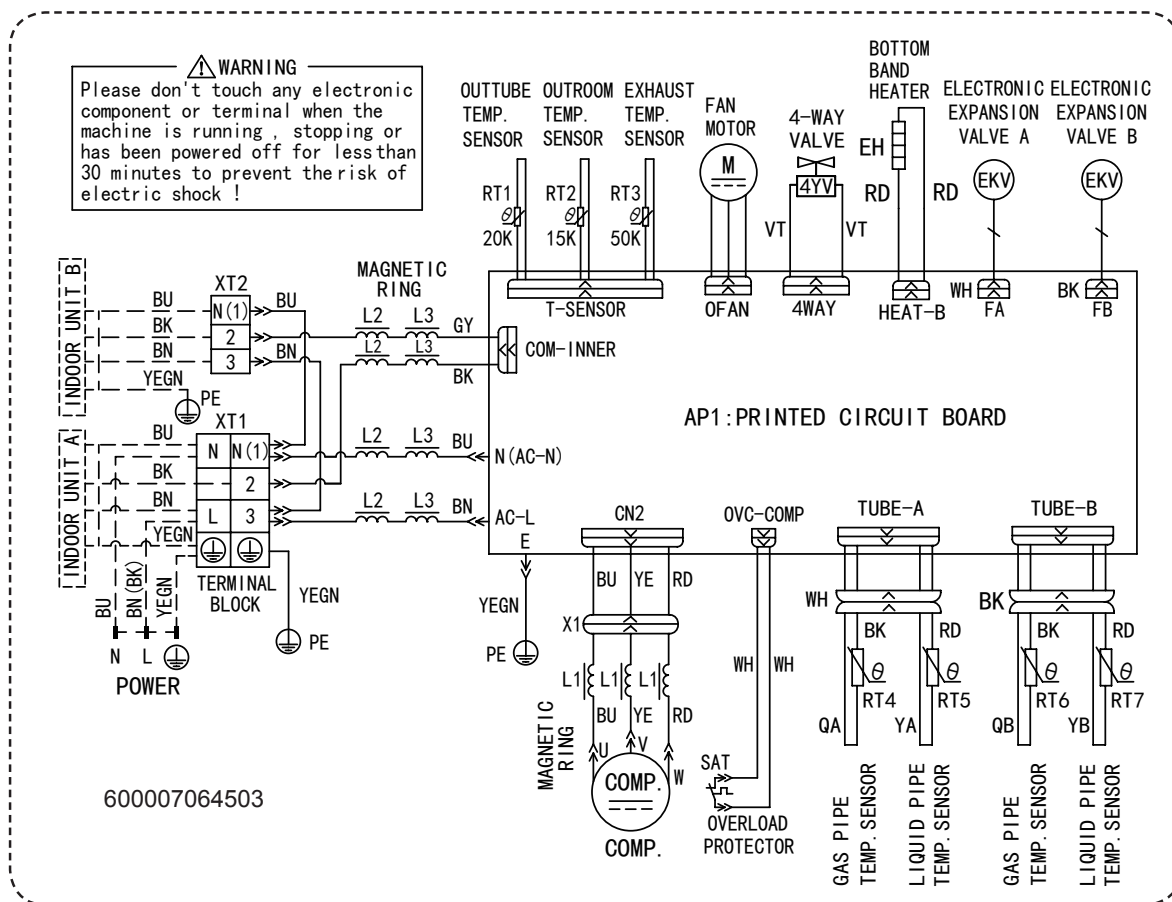

5. Electrical Part

MV-E21BI2
MV-E24BI2

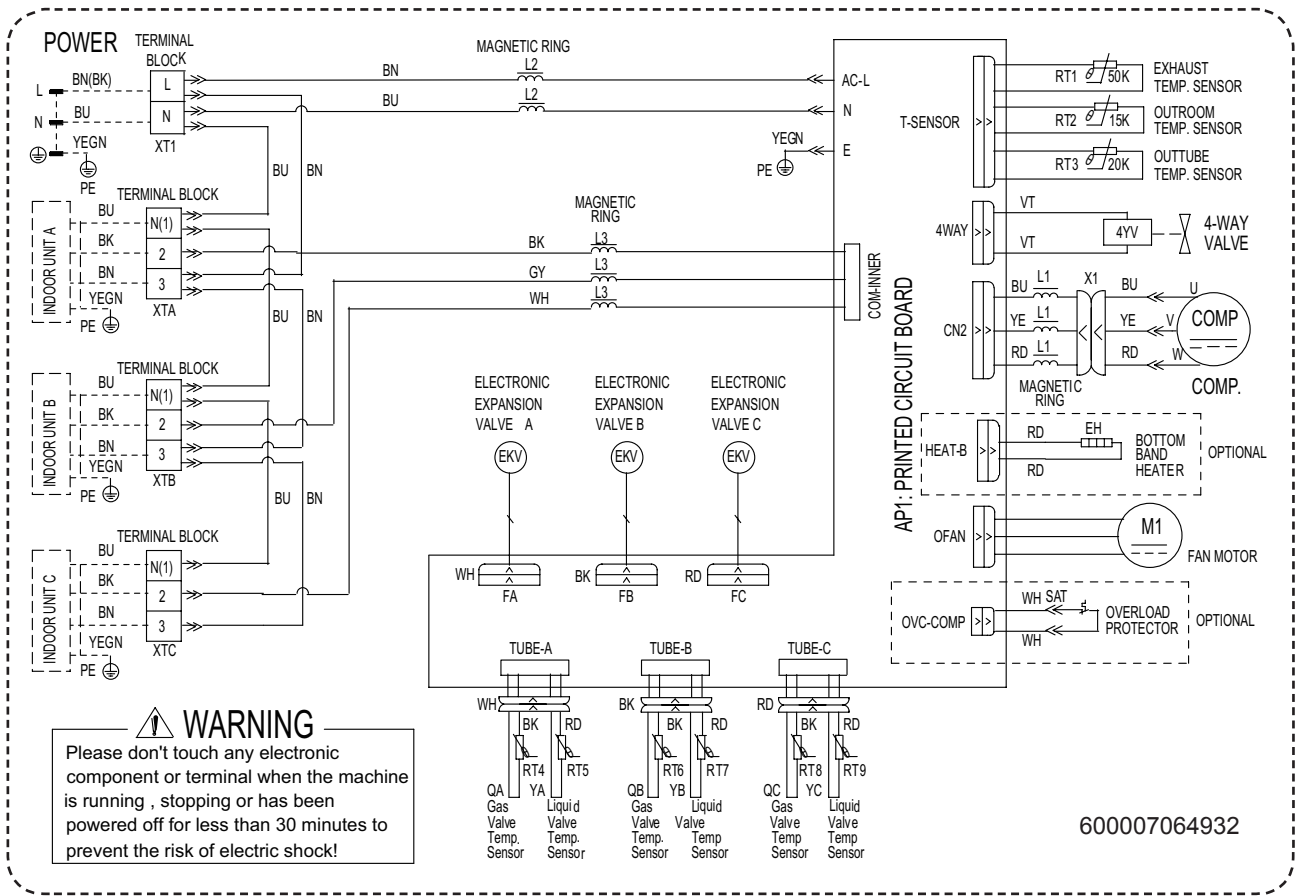

WARNING
Please don't touch any electronic component or terminal when the machine is running, stopping or has been powered off for less than 30 minutes to prevent the risk of electric shock!

600007064932

5. Electrical Part

MV-E28BI2

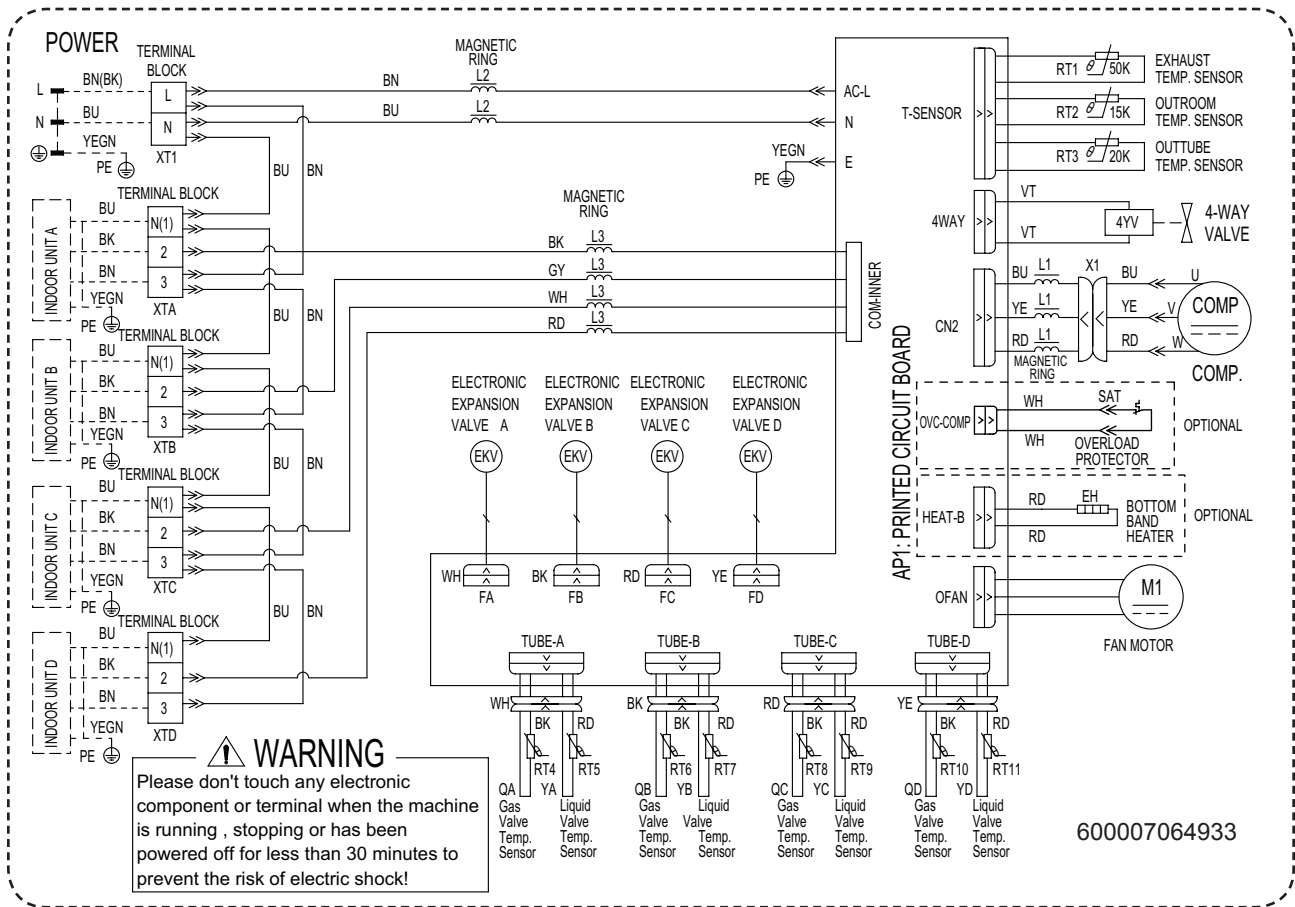

MV-E36BI2

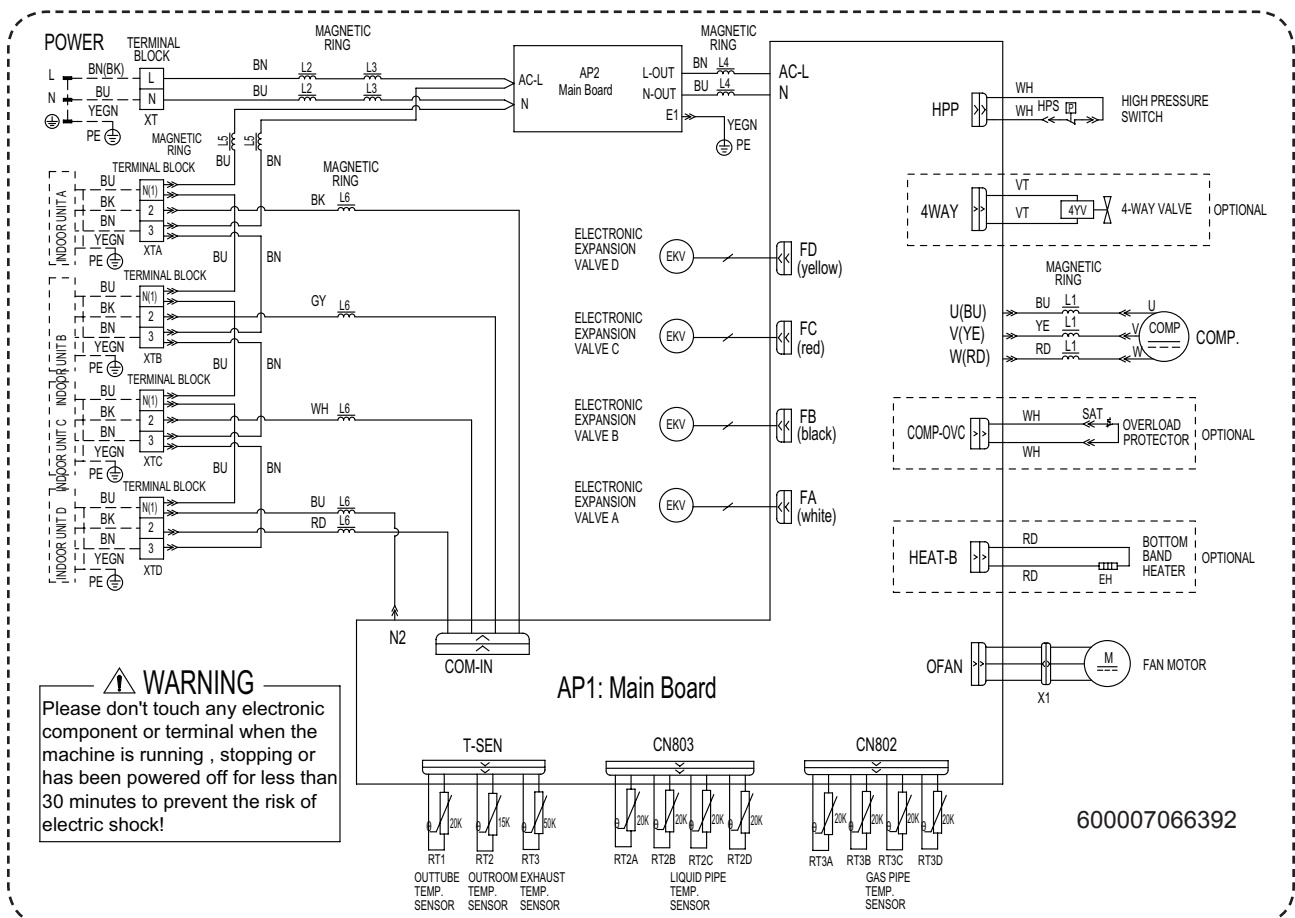

5. Electrical Part

MV-E42BI2

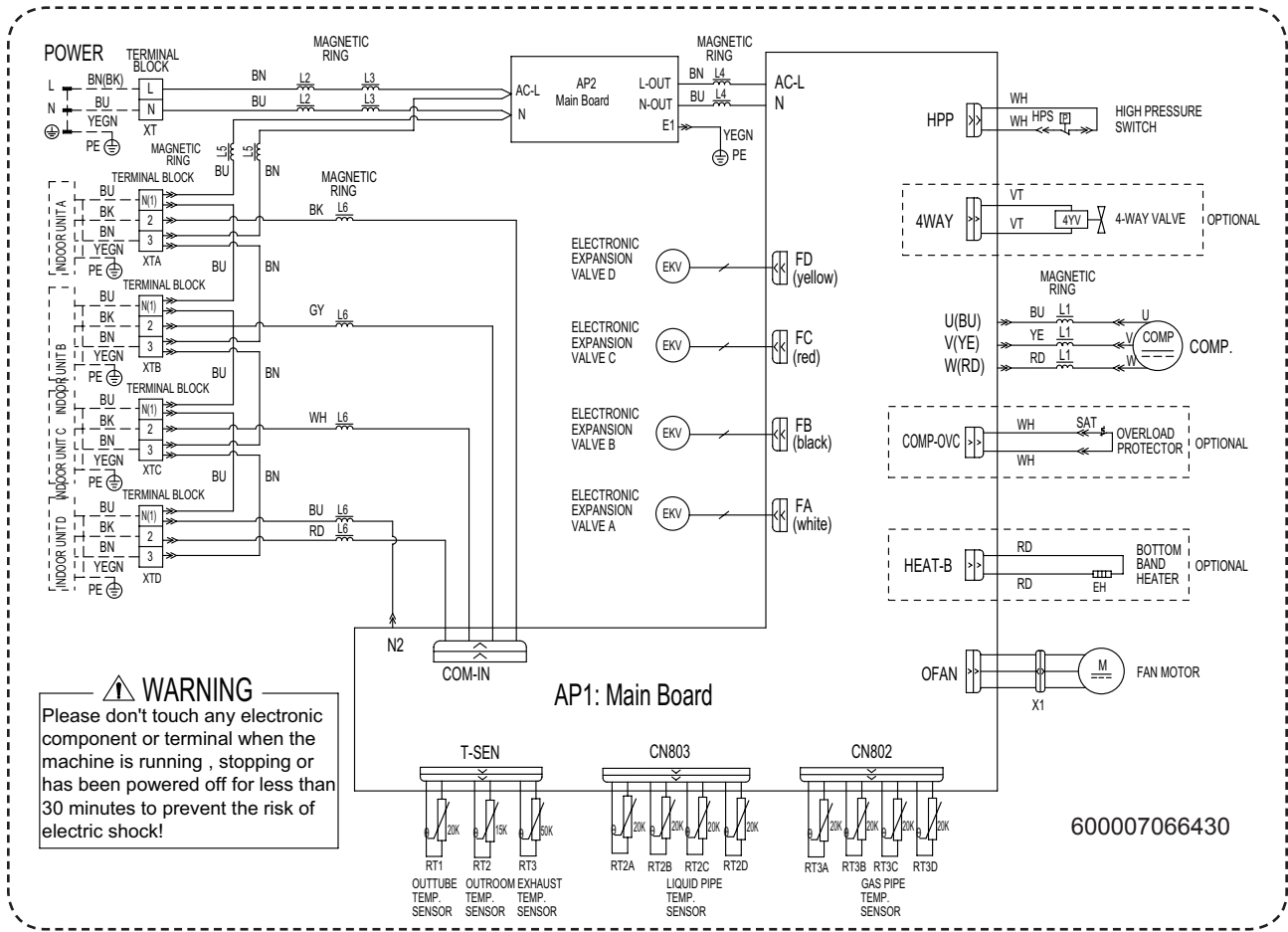

These wiring diagrams are subject to change without notice; please refer to the one supplied with the unit.

5. Electrical Part

5.2 PCB Printed Diagram

MV-E14BI2
MV-E18BI2

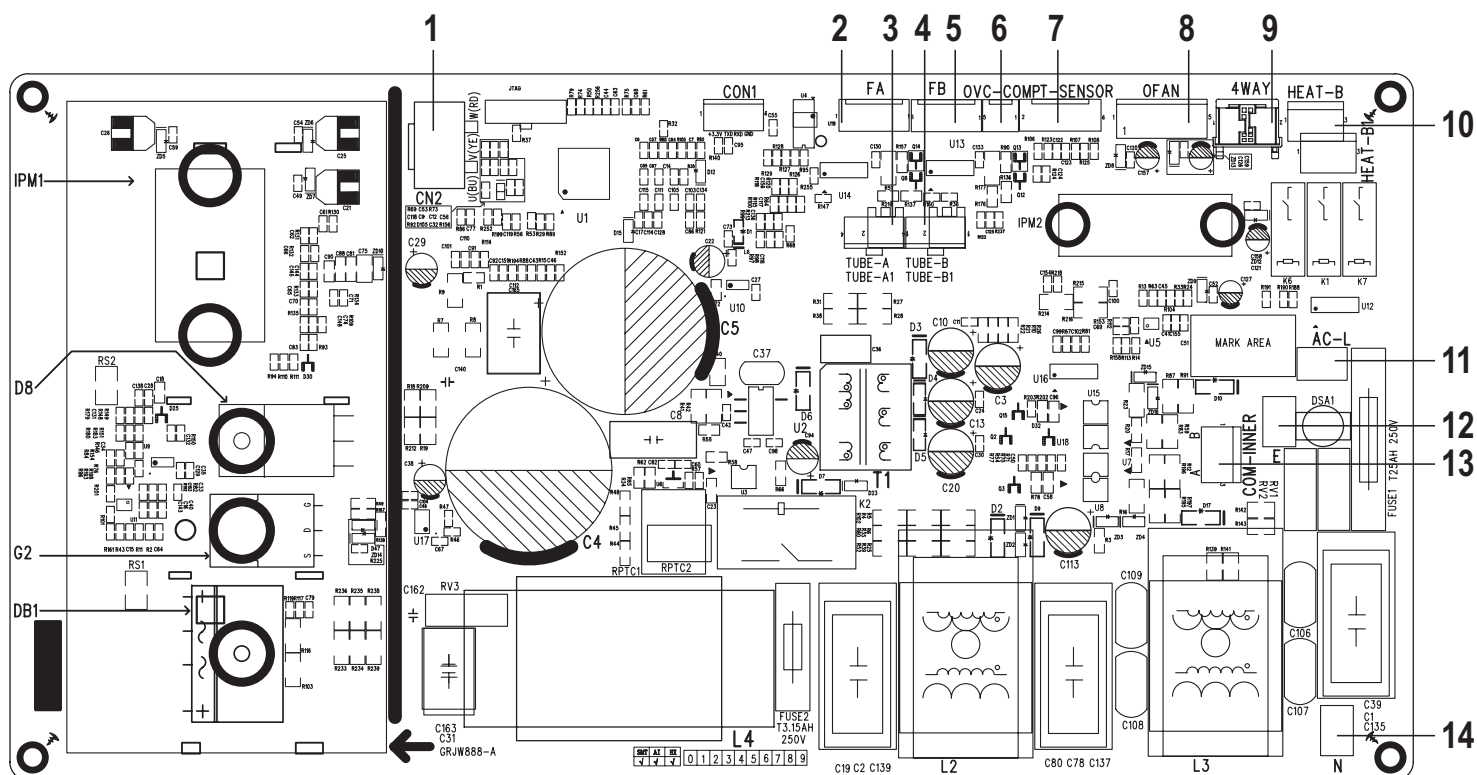

| No. | Name |
|-----|---|
| 1 | Terminal of compressor |
| 2 | Terminal of electronic expansion valve A |
| 3 | Terminal of gas-liquid valve temperature Sensor A |
| 4 | Terminal of gas-liquid valve temperature Sensor B |
| 5 | Terminal of electronic expansion valve B |
| 6 | Overload protection terminal of compressor |
| 7 | Terminal of temperature Sensor |

| No. | Name |
|-----|--------------------------------------|
| 8 | Terminal of outdoor fan |
| 9 | Terminal of 4-way valve |
| 10 | Electric heating terminal of chassis |
| 11 | Terminal of live wire |
| 12 | Terminal of grounding wire |
| 13 | Terminal of communication wire |
| 14 | Terminal of neutral wire |

5. Electrical Part

MV-E21BI2
MV-E24BI2
MV-E28BI2

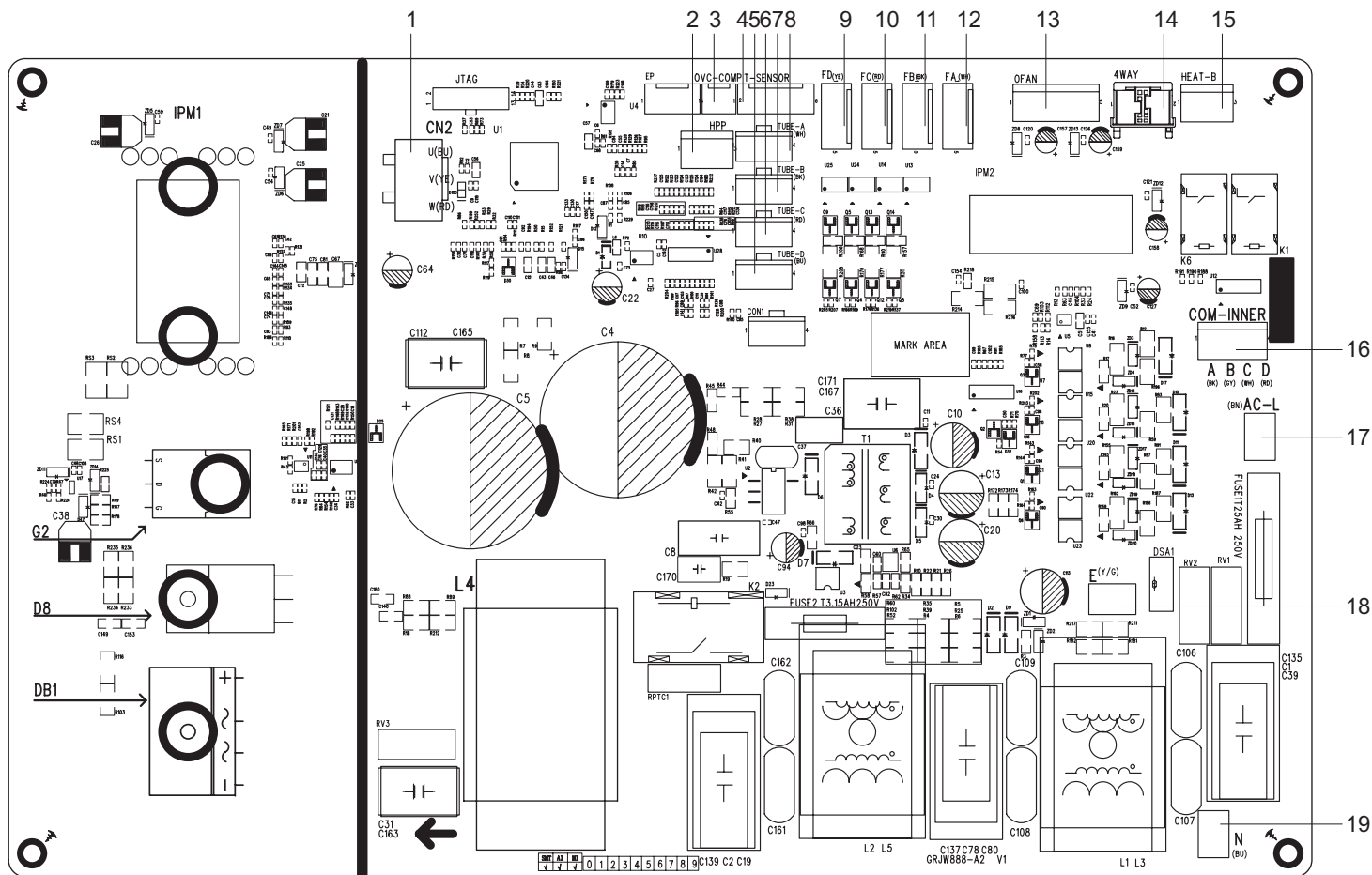

| No. | Name |
|-----|---|
| 1 | Terminal of compressor |
| 2 | Terminal of high pressure protection |
| 3 | Overload protection terminal of compressor |
| 4 | Terminal of gas-liquid valve temperature Sensor |
| 5 | Terminal of gas-liquid valve temperature Sensor D |
| 6 | Terminal of gas-liquid valve temperature Sensor C |
| 7 | Terminal of gas-liquid valve temperature Sensor B |
| 8 | Terminal of gas-liquid valve temperature Sensor A |
| 9 | Terminal of electronic expansion valve D |
| 10 | Terminal of electronic expansion valve C |

| No. | Name |
|-----|--|
| 11 | Terminal of electronic expansion valve B |
| 12 | Terminal of electronic expansion valve A |
| 13 | Terminal of outdoor fan |
| 14 | Terminal of 4-way valve |
| 15 | Electric heating terminal of chassis |
| 16 | Terminal of communication wire |
| 17 | Terminal of live wire |
| 18 | Terminal of grounding wire |
| 19 | Terminal of neutral wire |

5. Electrical Part

MV-E36BI2
MV-E42BI2

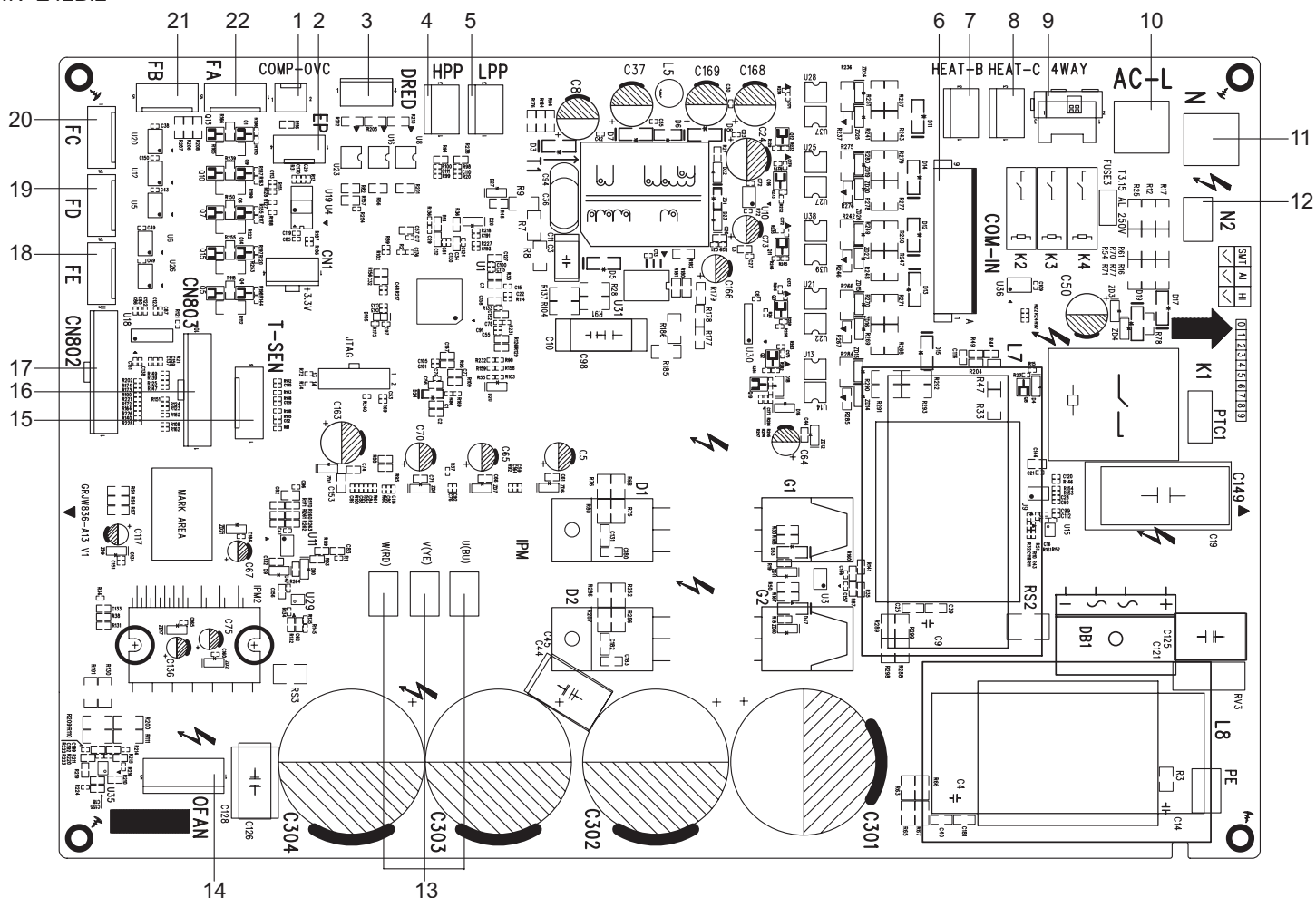

| No. | Name |
|-----|--|
| 1 | Overload protection terminal of compressor |
| 2 | Terminal of E disk |
| 3 | Terminal of DRED |
| 4 | Terminal of high pressure protection |
| 5 | Terminal of low pressure protection |
| 6 | Terminal of communication wire |
| 7 | Electric heating terminal of chassis |
| 8 | Electric heating terminal of compressor |
| 9 | Terminal of 4-way valve |
| 10 | Terminal of live wire |
| 11 | Terminal of neutral wire |

| No. | Name |
|-----|---|
| 12 | Terminal of communication neutral wire |
| 13 | Terminal of compressor |
| 14 | Terminal of outdoor fan |
| 15 | Terminal of temperature Sensor |
| 16 | Terminal of liquid valve temperature Sensor |
| 17 | Terminal of gas valve temperature Sensor |
| 18 | Terminal of electronic expansion valve E |
| 19 | Terminal of electronic expansion valve D |
| 20 | Terminal of electronic expansion valve C |
| 21 | Terminal of electronic expansion valve B |
| 22 | Terminal of electronic expansion valve A |

6. Function and Control

1 Basic functions of the system

1.1 Cooling Mode

1.1.1 Cooling conditions and process:

If the compressor is in stop status and start the unit for cooling operation, when one of the indoor units reaches the cooling operation condition, the unit start cooling operation; in this case, the electronic expansion valve, the outdoor fan and the compressor start operation.

1.1.2 Stop in cooling operation

1.1.2.1 Compressor stops

The compressor stops immediately, the outdoor fan stops after 1min.

1.1.2.2 Some of the indoor units reach the stop condition (the compressor does not stop)

The compressor operates immediately according to the required frequency. For the indoor unit with no requirement, the corresponding electronic expansion valve is closed to OP.

1.1.3 Cooling mode transfers to heating mode

When the unit transfers to heating mode, the 4-way valve is energized after the compressor stops for 2min. The other disposals are the same as stopping in cooling mode.

1.1.4 4-way valve: in this mode, the 4-way valve is closed.

1.1.5 Outdoor fan control in cooling mode

The outdoor fan starts before 5s of the starting of compressor. The outdoor fan will run in high speed for 3min after starting and then it will run in set speed. The fan shall run at every speed for at least 80s. (When the quantity of running indoor unit is changed, the unit will enter the control described in 1.3.5.1 and 1.3.5.2);

When the compressor stops, the outdoor fan runs at present speed and stops after 1min.

1.2 Dry Mode

1.2.1 The dry conditions and process are the same as those in cooling mode;

1.2.2 The status of 4-way valve: closed;

1.2.3 The temperature setting range: 16 ~ 30°C;

1.2.4 Protection function: the same as those in cooling mode;

1.2.5 In dry mode, the maximum value A of the capacity requirement percentage of single unit is 90% of that in cooling mode.

The open condition of the electronic expansion valve, outdoor fan and compressor is the same as those in cooling mode.

1.3 Heating Mode

1.3.1 Heating conditions and process:

When one of the indoor units reaches the heating operation condition, the unit starts heating operation.

1.3.2 Stop in heating operation:

1.3.2.1 When all the indoor units reach the stop condition, the compressor stops and the outdoor fan stops after 1min;

1.3.2.2 Some of the indoor units reach the stop condition

The compressor reduces the frequency immediately and operates according to the required frequency;

1.3.2.3 Heating mode transfers to cooling mode(dry mode), fan mode

a. The compressor stops; b. the power of 4-way valve is cut off after 2min; c. the outdoor fan stops after 1min; d. the status of 4-way valve: energized;

1.3.3 Outdoor fan control in heating mode

The outdoor fan starts before 5s of the starting of compressor and then it will run in high speed for 40s;

The fan shall run at every speed for at least 80s;

When the compressor stops, the outdoor fan stops after 1min.

1.3.4 Defrosting function

When the defrosting condition is met, the compressor stops; the electronic expansion valve of all indoor units open in big angle; the outdoor fan stops after 40s of the stop of compressor, meanwhile, the 4-way valve reverses the direction; after the 4-way valve reverses the direction, the compressor starts; then begin to calculate the time of defrosting, the frequency of the compressor rises to reach the defrosting frequency.

1.3.5 Oil-returned control in heating mode

1.3.5.1 Oil-returned condition

The whole unit is operating in low frequency for a long time.

1.3.5.2 Oil-returned process in heating mode

The indoor unit displays "H1".

1.3.5.3 Oil-returned finished condition in heating mode

The duration reaches 5min.

1.4 Fan Mode

The compressor, the outdoor fan and the 4-way valve are closed; temperature setting range is 16 ~ 30°C.

2 Protection Function

2.1 Mode Conflict Protection of indoor unit

When the setting mode is different of different indoor unit, the unit runs in below status:

a. The mode of the first operating indoor unit is the basic mode, then compare the mode of the other indoor units to see if there is a conflict. Cooling mode (dry mode) is in conflict with heating

6. Function and Control

mode.

b. Fan mode is in conflict with heating mode and the heating mode is the basic mode. No matter which indoor unit operates first, the unit will run in heating mode.

2.2 Overload protection function

When the tube temperature is a little low, the compressor raises the operation frequency; when the tube temperature is a little high, the compressor frequency is restricted or lows down the operation frequency; when the tube temperature is too high, the compressor protection stops running.

If the discharge temperature protection continuously appears for 6 times, the compressor can't resume running. The compressor can resume running after cutting off the power and then putting through the power. (if the running time of the compressor is longer than 7min, the protection times record will be cleared)

2.3 Discharge Protection Function

When the discharge temperature is a little low, the compressor raises the operation frequency; when the discharge temperature is a little high, the compressor frequency is restricted or lows down the operation frequency; when the discharge temperature is too high, the compressor protection stops running.

If the discharge temperature protection continuously appears for 6 times, the compressor can't resume running. The compressor can resume running after cutting off the power and then putting through the power. (if the running time of the compressor is longer than 7min, the protection times record will be cleared.)

2.4 Communication malfunction

Detection of the quantity of installed indoor units:

After 3min of energizing, if the outdoor unit does not receive the communication data of certain indoor unit, the outdoor unit will judge that indoor unit is not installed and will treat it as it is not installed. If the outdoor unit receives the communication data of that indoor unit later, the outdoor unit will treat that unit as it is installed.

2.5 Overcurrent Protection

a. Overcurrent protection of complete unit; b. phase wire current protection; c. compressor phase current protection

2.6 Compressor high-pressure protection

2.6.1 When the high-pressure switch is detected cut off for 3s continuously, the compressor will enter high-pressure protection as it stops when reaching set temperature. Meanwhile, the outdoor unit will send the signal of "high-pressure protection" to the indoor units;

2.6.2 After the appearance of high-pressure protection, when the high-pressure switch is detected closed for 6s continuously, the compressor can resume running only after cutting off the power

and then putting through the power.

2.7 Compressor overload protection

If the compressor overload switch is detected having movement, the indoor unit will display the corresponding malfunction as it stops when the indoor temperature reaching set temperature. When the compressor stops for more than 3min and the compressor overload switch is reset, the unit will resume operation status automatically. If the protection appears for more than 6 times (if the running time of the compressor is longer than 30min, the protection times record will be cleared), the unit can not resume operation status automatically, but can resume running only after cutting off the power and then putting through the power.

2.8 Compressor Phase-lacking Protection

When the compressor starts, if one of the three phases is detected open, the compressor will enter phase-lacking protection. The malfunction will be cleared after 1min, the unit will restart and then detect if there is still has phase-lacking protection. If the phase-lacking protection is detected for 6 times continuously, the compressor will not restart but can resume running only after cutting off the power and then putting through the power. If the running time of the compressor is longer than 7min, the protection times record will be cleared.

2.9 IPM Protection

2.9.1 When the IPM module protection is detected, the unit will stop as the indoor temperature reaching set temperature, PFC is closed, display IPM protection malfunction. After the compressor stops for 3min, the unit will resume operation status automatically; if the IPM protection is detected for more than 6 times continuously (If the running time of the compressor is longer than 7min, the protection times record will be cleared), the system will stop and send the signal of module protection to indoor unit. The unit can not resume operation status automatically, but can resume running only after cutting off the power and then putting through the power.

2.9.2 IPM module overheating protection

2.9.2.1 When $TIPM > 85^{\circ}\text{C}$, prohibit to raise frequency;

2.9.2.2 When $TIPM \geq 90^{\circ}\text{C}$, the operation frequency of compressor lows down by 15% every 90s according to the present capacity requirement of the complete unit. It will keep 90s after lowing down the frequency. After lowing down the frequency, if $TIPM \geq 90^{\circ}\text{C}$, the unit will circulate the above movement until reaching the minimum frequency; if $85^{\circ}\text{C} < TIPM < 90^{\circ}\text{C}$, the unit will run at this frequency; when $TIPM < 85^{\circ}\text{C}$, the unit will run at the frequency according to the capacity requirement;

2.9.2.3 When $TIPM \geq 95^{\circ}\text{C}$, the compressor stops. After the compressor stops for 3min, if $TIPM < 85^{\circ}\text{C}$, the compressor and the outdoor fan will resume operation.

7. Notes for Installation and Maintenance

Safety Precautions: Important!

Please read the safety precautions carefully before installation and maintenance.

The following contents are very important for installation and maintenance.

Please follow the instructions below.

- The installation or maintenance must accord with the instructions.
- Comply with all national electrical codes and local electrical codes.
- Pay attention to the warnings and cautions in this manual.
- All installation and maintenance shall be performed by distributor or qualified person.
- All electric work must be performed by a licensed technician according to local regulations and the instructions given in this manual.
- Be caution during installation and maintenance. Prohibit incorrect operation to prevent electric shock, casualty and other accidents.



Warnings

Electrical Safety Precautions:

1. Cut off the power supply of air conditioner before checking and maintenance.
2. The air condition must apply specialized circuit and prohibit share the same circuit with other appliances.
3. The air conditioner should be installed in suitable location and ensure the power plug is touchable.
4. Make sure each wiring terminal is connected firmly during installation and maintenance.
5. Have the unit adequately grounded. The grounding wire can't be used for other purposes.
6. Must apply protective accessories such as protective boards, cable-cross loop and wire clip.
7. The live wire, neutral wire and grounding wire of power supply must be corresponding to the live wire, neutral wire and grounding wire of the air conditioner.
8. The power cord and power connection wires can't be pressed by hard objects.
9. If power cord or connection wire is broken, it must be replaced by a qualified person.
10. If the power cord or connection wire is not long enough, please get the specialized power cord or connection wire from the manufacture or distributor. Prohibit prolong the wire by yourself.
11. For the air conditioner without plug, an air switch must be installed in the circuit. The air switch should be all-pole parting and the contact parting distance should be more than 3m.
12. Make sure all wires and pipes are connected properly and

the valves are opened before energizing.

13. Check if there is electric leakage on the unit body. If yes, please eliminate the electric leakage.
14. Replace the fuse with a new one of the same specification if it is burnt down; don't replace it with a cooper wire or conducting wire.
15. If the unit is to be installed in a humid place, the circuit breaker must be installed.

Installation Safety Precautions:

1. Select the installation location according to the requirement of this manual.(See the requirements in installation part)
2. Handle unit transportation with care; the unit should not be carried by only one person if it is more than 20kg.
3. When installing the indoor unit and outdoor unit, a sufficient fixing bolt must be installed; make sure the installation support is firm.
4. Ware safety belt if the height of working is above 2m.
5. Use equipped components or appointed components during installation.
6. Make sure no foreign objects are left in the unit after finishing installation.

Refrigerant Safety Precautions:

When refrigerant leaks or requires discharge during installation, maintenance, or disassembly, it should be handled by certified professionals or otherwise in compliance with local laws and regulations.

1. Avoid contact between refrigerant and fire as it generates poisonous gas; Prohibit prolong the connection pipe by welding.
2. Apply specified refrigerant only. Never have it mixed with any other refrigerant. Never have air remain in the refrigerant line as it may lead to rupture or other hazards.
3. Make sure no refrigerant gas is leaking out when installation is completed.
4. If there is refrigerant leakage, please take sufficient measure to minimize the density of refrigerant.
5. Never touch the refrigerant piping or compressor without wearing glove to avoid scald or frostbite.

Improper installation may lead to fire hazard, explosion, electric shock or injury.

7. Notes for Installation and Maintenance

Safety Precautions for Installing and Relocating the Unit:

To ensure safety, please be mindful of the following precautions.

WARNINGS

1. When installing or relocating the unit, be sure to keep the refrigerant circuit free from air or substances other than the specified refrigerant.

Any presence of air or other foreign substance in the refrigerant circuit will cause system pressure rise or compressor rupture, resulting in injury.

2. When installing or moving this unit, do not charge the refrigerant which is not comply with that on the nameplate or unqualified refrigerant.

Otherwise, it may cause abnormal operation, wrong action, mechanical malfunction or even series safety accident.

3. When refrigerant needs to be recovered during relocating or repairing the unit, be sure that the unit is running in cooling mode. Then, fully close the valve at high pressure side (liquid valve). About 30-40 seconds later, fully close the valve at low pressure side (gas valve), immediately stop the unit and disconnect power. Please note that the time for refrigerant recovery should not exceed 1 minute.

If refrigerant recovery takes too much time, air may be sucked in and cause pressure rise or compressor rupture, resulting in injury.

4. During refrigerant recovery, make sure that liquid valve and gas valve are fully closed and power is disconnected before detaching the connection pipe.

If compressor starts running when stop valve is open and connection pipe is not yet connected, air will be sucked in and cause pressure rise or compressor rupture, resulting in injury.

5. When installing the unit, make sure that connection pipe is securely connected before the compressor starts running.

If compressor starts running when stop valve is open and connection pipe is not yet connected, air will be sucked in and cause pressure rise or compressor rupture, resulting in injury.

6. Prohibit installing the unit at the place where there may be leaked corrosive gas or flammable gas.

If there leaked gas around the unit, it may cause explosion and other accidents.

7. Do not use extension cords for electrical connections. If the electric wire is not long enough, please contact a local service center authorized and ask for a proper electric wire.

Poor connections may lead to electric shock or fire.

8. Use the specified types of wires for electrical connections between the indoor and outdoor units. Firmly clamp the wires so that their terminals receive no external stresses.

Electric wires with insufficient capacity, wrong wire connections and insecure wire terminals may cause electric shock or fire.

7. Notes for Installation and Maintenance

Safety Precautions for Refrigerant

●To realize the function of the air conditioner unit, a special refrigerant circulates in the system. The used refrigerant is the fluoride R32, which is specially cleaned. The refrigerant is flammable and inodorous. Furthermore, it can lead to explosion under certain conditions. But the flammability of the refrigerant is very low. It can be ignited only by fire.

●Compared to common refrigerants, R32 is a nonpolluting refrigerant with no harm to the ozoneosphere. The influence upon the greenhouse effect is also lower. R32 has got very good thermodynamic features which lead to a really high energy efficiency. The units therefore need a less filling.

WARNING:

●Do not use means to accelerate the defrosting process or to clean, other than those recommended by the manufacture.

Should repair be necessary, contact your nearest authorized Service Centre. Any repairs carried out by unqualified personnel may be dangerous. The appliance shall be stored in a room without continuously operating ignition sources. (For example: open flames, an operating gas appliance or an operating electric heater.)

●Do not pierce or burn.

●Appliance shall be installed, operated and stored in a room with a floor area larger than Xm^2 .

●Appliance filled with flammable gas R32. For repairs, strictly follow manufacturers instructions only. Be aware that refrigerants not contain odour.

●Read specialists manual.

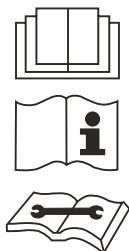

Safety Operation of Flammable Refrigerant

Qualification requirement for installation and maintenance man

●All the work men who are engaging in the refrigeration system should bear the valid certification awarded by the authoritative organization and the qualification for dealing with the refrigeration system recognized by this industry. If it needs other technician to maintain and repair the appliance, they should be supervised by the person who bears the qualification for using the flammable refrigerant.

●It can only be repaired by the method suggested by the equipments manufacturer.

Installation notes

●The air conditioner is not allowed to use in a room that has running fire (such as fire source, working coal gas ware, operating heater).

●It is not allowed to drill hole or burn the connection pipe.

●The air conditioner must be installed in a room that is larger

than the minimum room area.

The minimum room area is shown on the nameplate or following table a.

●Leak test is a must after installation.

table a - Minimum room area (m²)

| Charge amount (kg) | floor location | window mounted | wall mounted | ceiling mounted |
|--------------------|----------------|----------------|--------------|-----------------|
| ≤1.2 | / | / | / | / |
| 1.3 | 14.5 | 5.2 | 1.6 | 1.1 |
| 1.4 | 16.8 | 6.1 | 1.9 | 1.3 |
| 1.5 | 19.3 | 7 | 2.1 | 1.4 |
| 1.6 | 22 | 7.9 | 2.4 | 1.6 |
| 1.7 | 24.8 | 8.9 | 2.8 | 1.8 |
| 1.8 | 27.8 | 10 | 3.1 | 2.1 |
| 1.9 | 31 | 11.2 | 3.4 | 2.3 |
| 2 | 34.3 | 12.4 | 3.8 | 2.6 |
| 2.1 | 37.8 | 13.6 | 4.2 | 2.8 |
| 2.2 | 41.5 | 15 | 4.6 | 3.1 |
| 2.3 | 45.4 | 16.3 | 5 | 3.4 |
| 2.4 | 49.4 | 17.8 | 5.5 | 3.7 |
| 2.5 | 53.6 | 19.3 | 6 | 4 |

Maintenance notes

●Check whether the maintenance area or the room area meet the requirement of the nameplate.

— Its only allowed to be operated in the rooms that meet the requirement of the nameplate.

●Check whether the maintenance area is well-ventilated.

— The continuous ventilation status should be kept during the operation process.

●Check whether there is fire source or potential fire source in the maintenance area.

— The naked flame is prohibited in the maintenance area; and the “no smoking” warning board should be hanged.

●Check whether the appliance mark is in good condition.

— Replace the vague or damaged warning mark.

Welding

●If you should cut or weld the refrigerant system pipes in the process of maintaining, please follow the steps as below:

- Shut down the unit and cut power supply
- Eliminate the refrigerant
- Vacuuming
- Clean it with N₂ gas
- Cutting or welding
- Carry back to the service spot for welding

7. Notes for Installation and Maintenance

- Make sure that there isn't any naked flame near the outlet of the vacuum pump and its well-ventilated.

- The refrigerant should be recycled into the specialized storage tank.

Filling the refrigerant

- Use the refrigerant filling appliances specialized for R32. Make sure that different kinds of refrigerant won't contaminate with each other.

- The refrigerant tank should be kept upright at the time of filling refrigerant.

- Stick the label on the system after filling is finished (or

haven't finished).

- Don't overfilling.

- After filling is finished, please do the leakage detection before test running; another time of leak detection should be done when its removed.

Safety instructions for transportation and storage

- Please use the flammable gas detector to check before unload and open the container.

- No fire source and smoking.

- According to the local rules and laws.

7. Notes for Installation and Maintenance

Main Tools for Installation and Maintenance



8. Installation

Installation Procedures

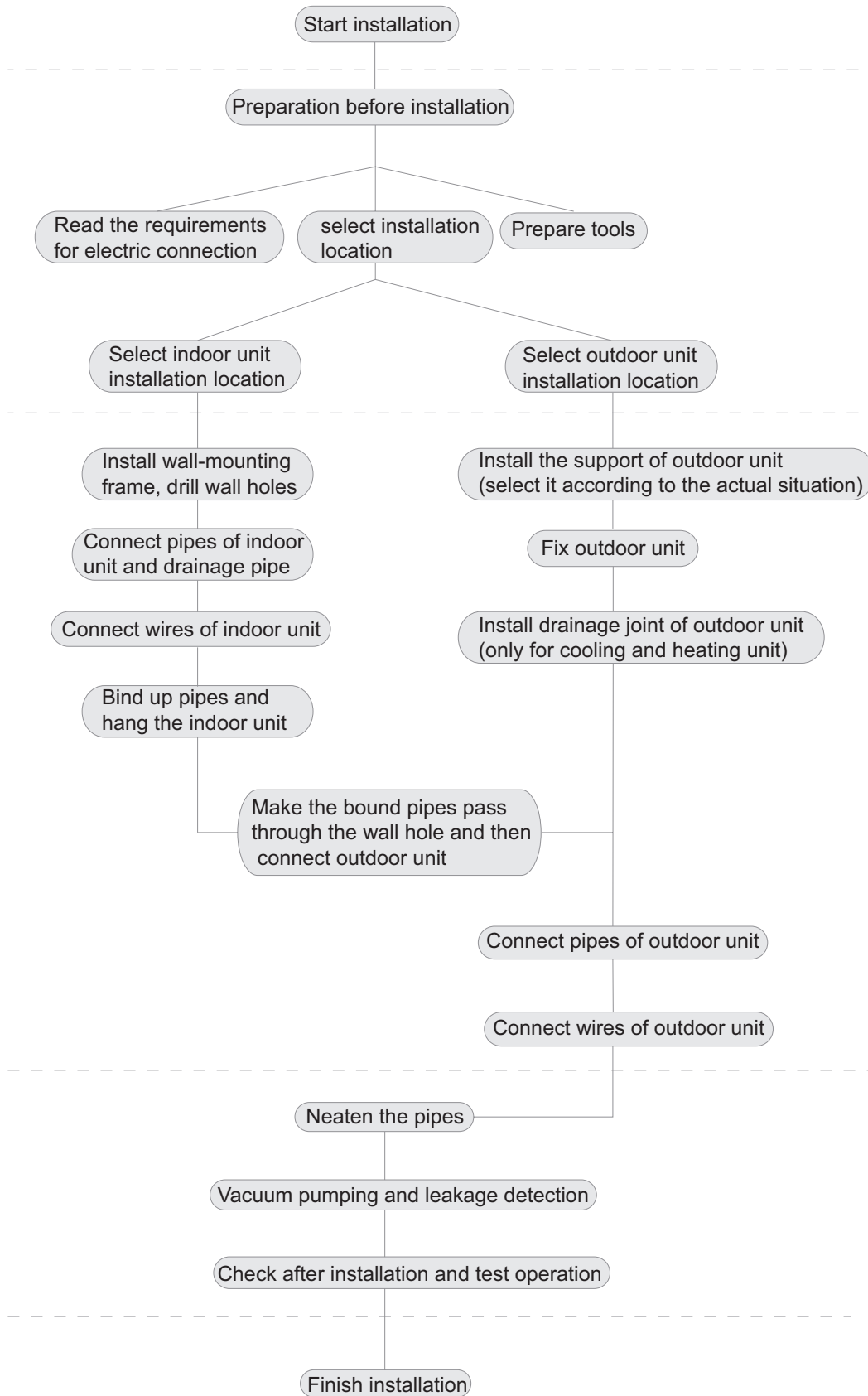

Note: this flow is only for reference; please find the more detailed installation steps in this section.

8. Installation

8.1 Electrical Connections

1. Remove the handle at the right side plate of the outdoor unit (one screw).
2. Remove the cable clamp, connect the power connection cable with the terminal at the row of connection and fix the connection. The fitting line distributing must be consistent with the indoor unit terminal of line bank. Wiring should meet that of indoor unit.
3. Fix power connection wire by wire clamp.
4. Ensure wire has been fixed well.
5. Install the handle.

△ Including an air switch with suitable capacity, please note the following table. Air switch should be included magnet buckle and heating buckle function, it can protect the circuit-short and overload. (Caution: please do not use the fuse only for protect the circuit)

| Air-conditioner | Air switch capacity |
|-------------------------------------|---------------------|
| MV-E14BI2 MV-E18BI2 | 16A |
| MV-E21BI2 MV-E24BI2 MV-E28BI2 | 25A |
| MV-E36BI2 MV-E42BI2 | 32A |

- △ An all-pole disconnection switch having a contact separation of at least 3mm in all pole should be connected in fixed wiring.
- △ Wrong wire connection may cause malfunction of some electric components. After fixing cable, ensure that leads between connection to fixed point have some space.
- △ For 14K/18K, the connection pipes and the connecting wirings of the unit A, unit B must be corresponding to each other respective.
- △ For 21K/24K, the connection pipes and the connecting wirings of the unit A, unit B, unit C must be corresponding to each other respective.
- △ For 28K/36K, the connection pipes and the connecting wirings of the unit A, unit B, unit C, unit D must be corresponding to each other respective.
- △ For 42K, the connection pipes and the connecting wirings of the unit A, unit B, unit C, unit D, unit E must be corresponding to each other respective.
- △ The appliance shall be installed in accordance with national wiring regulations.

Note: the above figures are only intended to be a simple diagram of the appliance and may not correspond to the appearance of the units that have been purchased.

MV-E14/18BI2

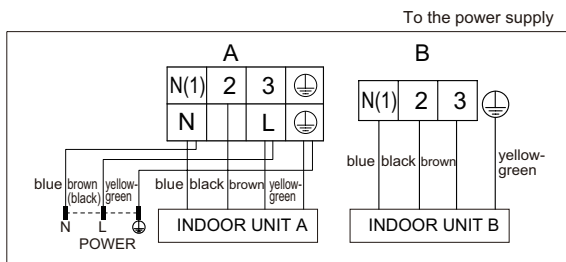
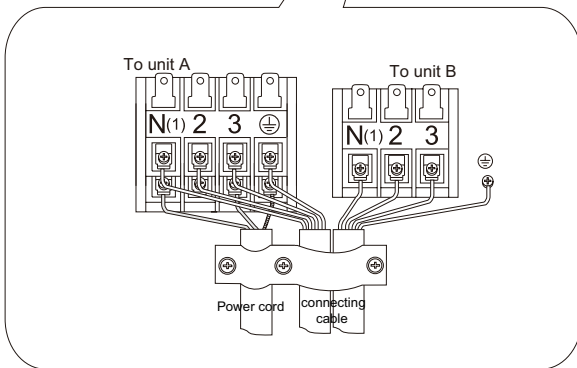
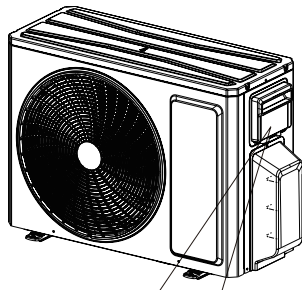

MV-E21/24BI2

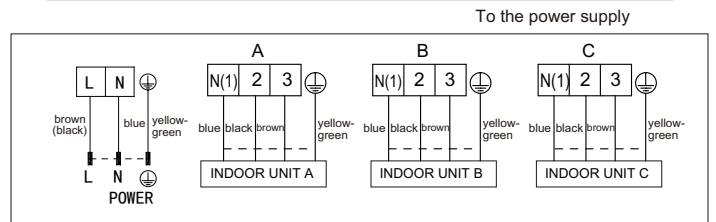
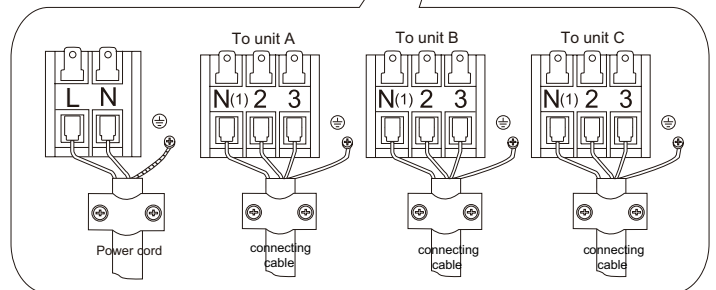
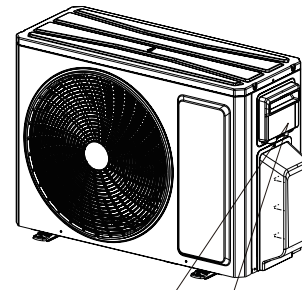

8. Installation

MV-E28/36BI2

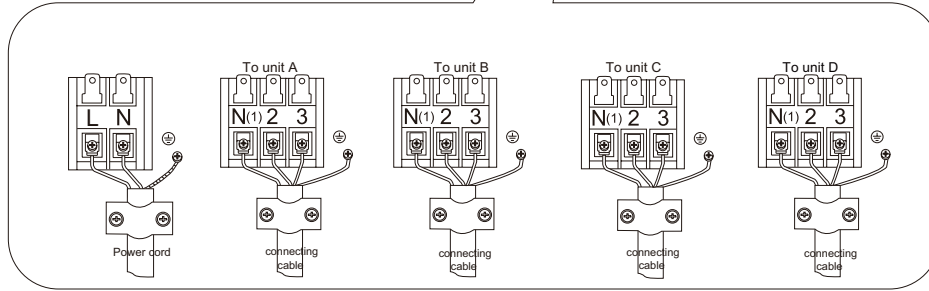
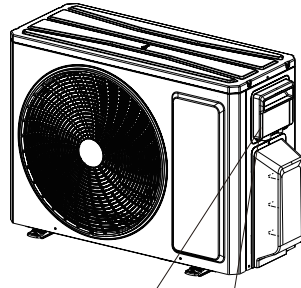

To the power supply

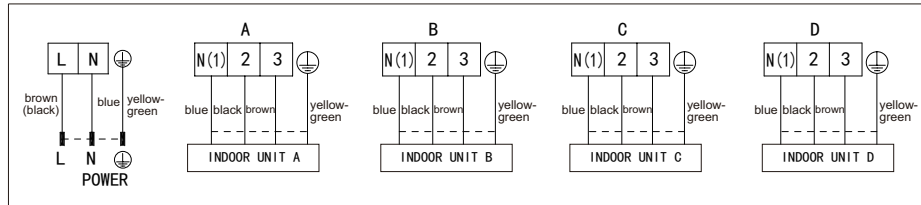

MV-E42BI2

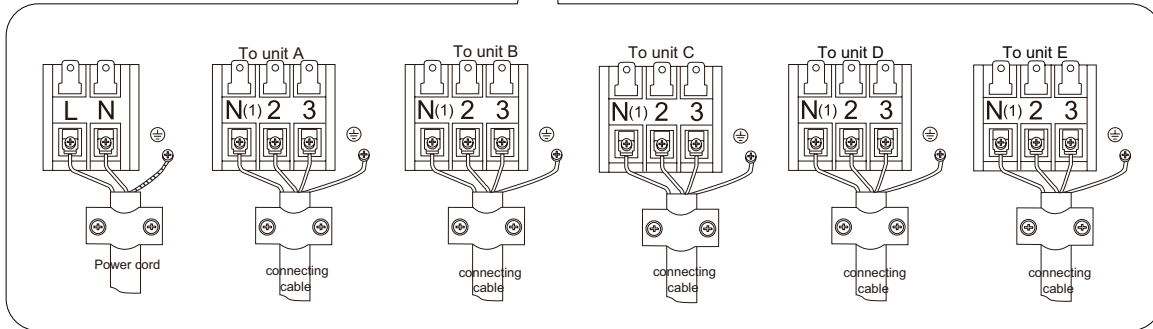
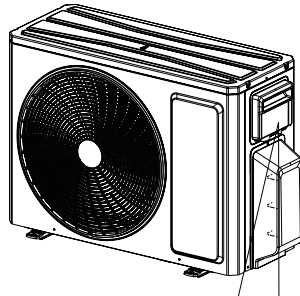

To the power supply

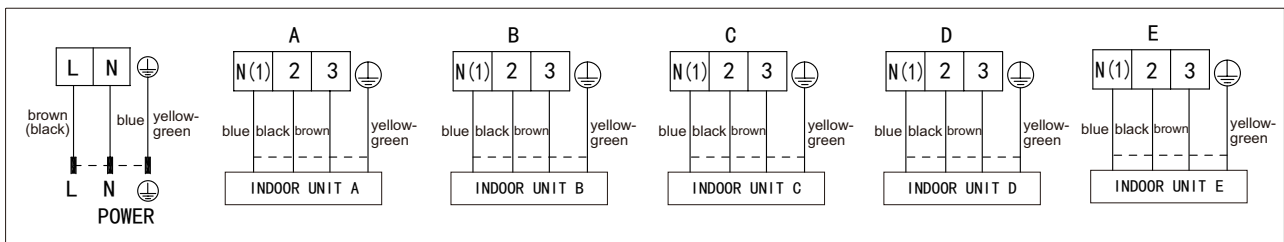

8. Installation

8.2 Installing the Outdoor Unit

▲ Use bolts to secure the unit to a flat, solid floor.

When mounting the unit on a wall or the roof, make sure the support is firmly secured so that it cannot move in the event of intense vibrations or a strong wind.

▲ Do not install the outdoor unit in pits or air vents.

Installing the pipes

▲ Use suitable connecting pipes and equipment for the refrigerant R32.

| Models(m) | 14Kx2 /18Kx2 | 21Kx3 /24Kx3 | 28Kx4 | 36Kx4 | 42Kx5 |
|---|-----------------|-----------------|-------|-------|-------|
| Max. connection pipe length | 40 | 60 | 70 | 80 | 100 |
| Max. connection pipe length (Simpleone indoor unit) | 20 | 20 | 20 | 25 | 25 |

The sum of the capacity codes of the indoor units should be among 50%-150% of that of the outdoor unit.

▲ The refrigerant pipes must not exceed the maximum heights 5m.

▲ Wrap all the refrigerant pipes and joints.

▲ Tighten the connections using two wrenches working in opposite directions.

Caution: Installation Must be Performed in Accordance with the NEC/CEC by Authorized Personnel Only.

Humid air left inside the refrigerant circuit can cause compressor malfunction. After having connected the indoor and outdoor units, bleed the air and humidity from the refrigerant circuit using a vacuum pump.

- (1) Unscrew and remove the caps from the 2-way and 3-way valves.
- (2) Unscrew and remove the cap from the service valve.
- (3) Connect the vacuum pump hose to the service valve.
- (4) Operate the vacuum pump for 10-15 minutes until an absolute vacuum of 10 mm Hg has been reached.
- (5) With the vacuum pump still in operation, close the low-pressure knob on the vacuum pump coupling. Stop the vacuum pump.
- (6) Open the 2-way valve by 1/4 turn and then close it after 10 seconds. Check all the joints for leaks using liquid soap or an electronic leak device.
- (7) Turn the body of the 2-way and 3-way valves. Disconnect the vacuum pump hose.
- (8) Replace and tighten all the caps on the valves.

| Piping size (inch) | Twisting moment (N·m) |
|--------------------|-----------------------|
| Φ1/4 | 15-20 |
| Φ3/8 | 35-40 |
| Φ1/2 | 60-65 |
| Φ5/8 | 45-50 |
| Φ3/4 | 70-75 |

(9) If the specification of outdoor unit gas valve is 3/8", but customer needs to install 1/2" indoor unit so that it is need to use a "pipe joint subassembly" (Code 06643008) to make a conversion joint with outdoor unit gas valve and connection pipe, as show in following.

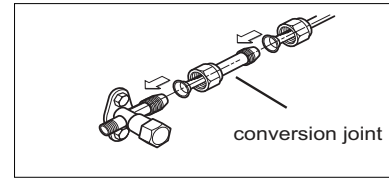

Install the drain fitting and the drain hose(for model with heat pump only)

Condensation is produced and flows from the outdoor unit when the appliance is operating in the heating mode. In order not to disturb neighbours and to respect the environment, install a drain fitting and a drain hose to channel the condensate water. Install the drain fitting and rubber washer on the outdoor unit chassis and connect a drain hose to it as shown in the figure.

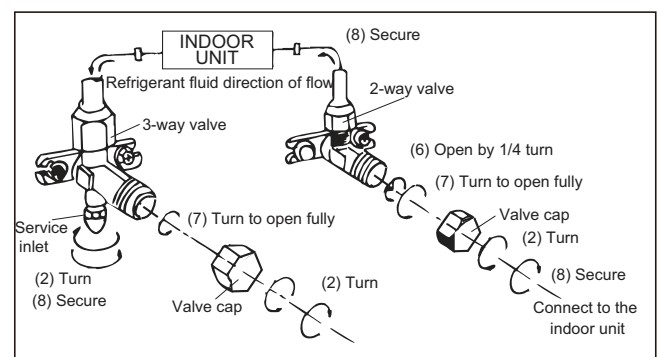
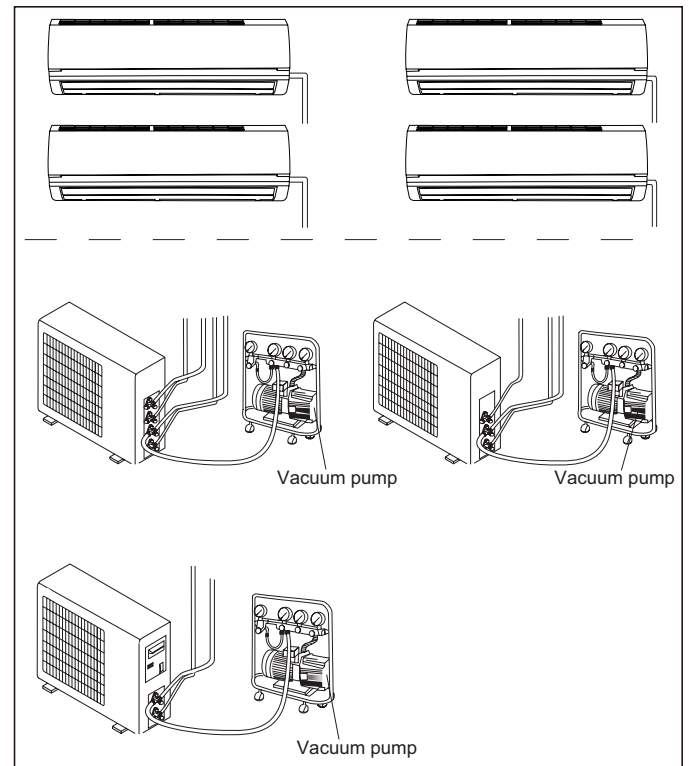
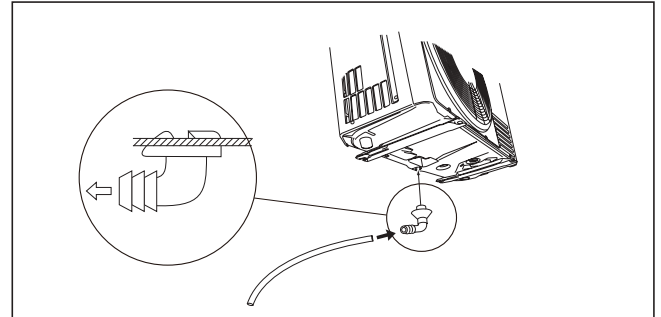

8. Installation

8.3 Installation Dimension Diagram

- ⚠ Use suitable instruments for the refrigerant R32.
- ⚠ Do not use any other refrigerant than R32.
- ⚠ Do not use mineral oils to clean the unit.

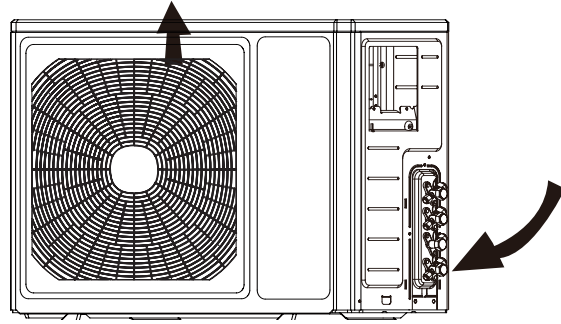

- ⚠ The installation must be done by trained and qualified service personnel with reliability according to this manual.
- ⚠ Contact service center before installation to avoid the malfunction due to unprofessional installation.
- ⚠ When picking up and moving the units, you must be guided by trained and qualified person.
- ⚠ Ensure that the recommended space is left around the appliance.

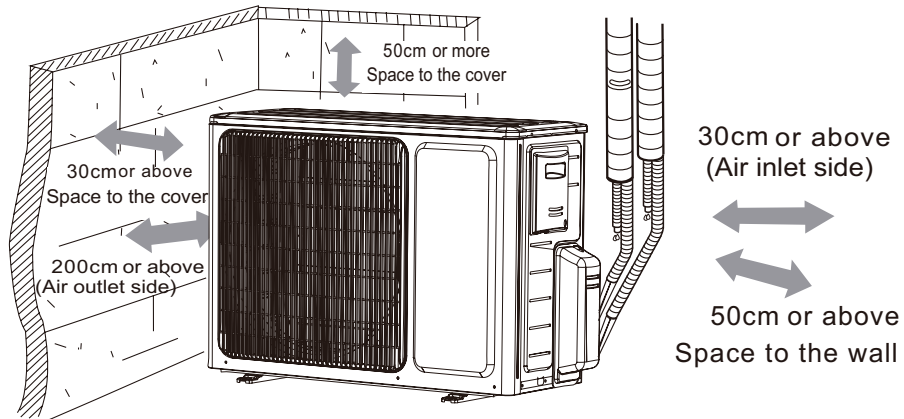

8. Installation

8.4 Check after Installation

| Check Items | Problems Owing to Improper Installation |
|---|---|
| Is the installation reliable? | The unit may drop, vibrate or make noises |
| Has the gas leakage been checked? | May cause unsatisfactory cooling (heating) effect |
| Is the thermal insulation of the unit sufficient? | May cause condensation and water dropping |
| Is the drainage smooth? | May cause condensation and water dropping |
| Does the power supply voltage accord with the rated voltage specified on the nameplate? | The unit may bread down or the components may be burned out |
| Are the lines and pipelines correctly installed? | The unit may bread down or the components may be burned out |
| Has the unit been safely grounded? | Risk of electrical leakage |
| Are the models of lines in conformity with requirements? | The unit may bread down or the components may be burned out |
| Are there any obstacles near the air inlet and outlet of the indoor and outdoor units? | The unit may bread down or the components may be burned out |
| Have the length of refrigerating pipe and refrigerant charge amount been recorded? | It is not easy to decide the charge amount of refrigerant. |

9. Maintenance

9.1 Precautions before Performing Inspection or Repair

There are high-capacity electrolytic capacitors on the outdoor mainboard. Thus, even the power is cut off, there is high voltage inside the capacitors and it needs more than 20min to reduce the voltage to safety value. Touching the electrolytic capacitor within 20min after cutting the power will cause electric shock. If maintenance is needed, follow the steps below to discharge electricity of electrolytic capacitor after power off.

(1) Open the top cover of outdoor unit and then remove the cover of electric box cover.

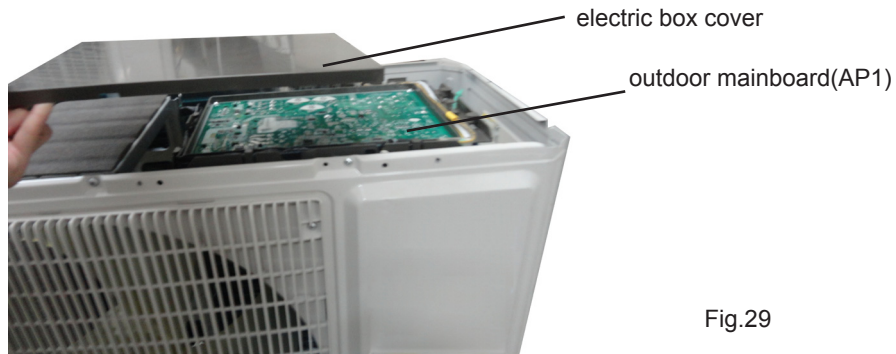

Fig.29

(2) As shown in the fig below, connect the plug of discharge resistance (about 100ohm, 20W) (if there is no discharge resistance, you can use the plug of soldering iron) to point A and B of electrolytic capacitor. There will be sparks when touching them. Press them forcibly for 30s to discharge electricity of electrolytic capacitor.

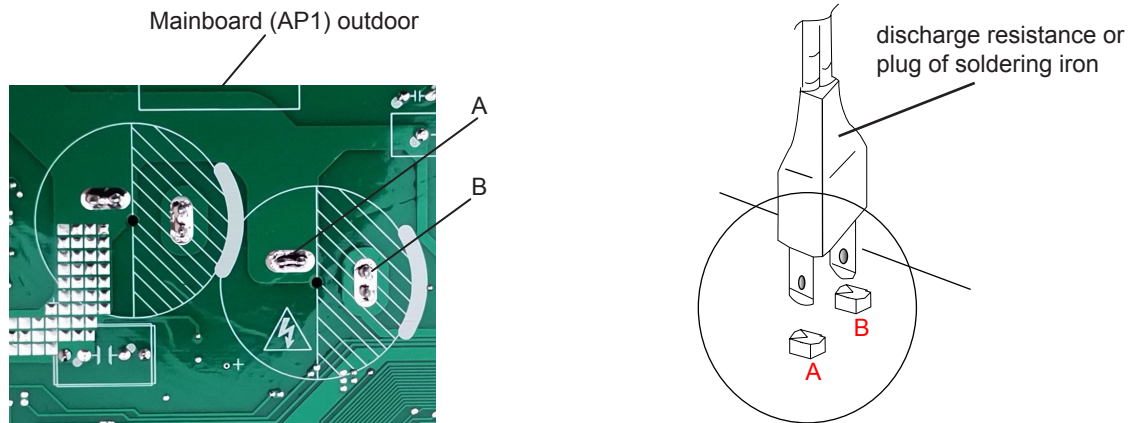

Fig.30

(3) After finish discharging electricity, measure the voltage between point A and B with universal meter to make sure if electricity discharging is completed, in order to prevent electric shock. If the voltage between the two points is below 20V, you can perform maintenance safely.

9. Maintenance

9.2 Flashing LED of Indoor/Outdoor Unit and Primary Judgement

1. Requirement of malfunction display

When several malfunctions happen at the same time, malfunction codes will be displayed circularly.

2. Malfunction display method

(1) Hardware malfunction: it will be displayed immediately, please refer to “Malfunction status sheet”;

(2) Operation status: it will be displayed immediately, please refer to “Malfunction status sheet”;

(3) Other malfunction: It will be displayed after the compressor has been stopped for 200s, please refer to “Malfunction status sheet”.

(Note: when the compressor starts up again, malfunction display waiting time (200s) will be cleared.)

3. Malfunction display control

Indoor unit displays malfunction code as shown in the sheet below. ODU communication light will be off for 1s and then blink for 1s circularly.

| Malfunction status sheet | | |
|--|--|------------|
| Malfunction name | Malfunction type | Nixie tube |
| Zero cross detection circuit malfunction | Hardware malfunction | U8 |
| Malfunction protection of jumper cap | Hardware malfunction | C5 |
| Feedback of without IDU motor | Hardware malfunction | H6 |
| Indoor ambient temperature sensor is open/short circuited | Hardware malfunction | F1 |
| Indoor evaporator temperature sensor is open/short circuited | Hardware malfunction | F2 |
| Liquid valve temperature sensor is open/short circuited | Hardware malfunction | b5 |
| Gas valve temperature sensor is open/short circuited | Hardware malfunction | b7 |
| Modular temperature sensor is open/short circuited | Hardware malfunction | P7 |
| Outdoor ambient temperature sensor is open/short circuited | Hardware malfunction | F3 |
| Outdoor condenser middle pipe temperature sensor is open/short circuited | Hardware malfunction | F4 |
| Outdoor discharge temperature sensor is open/short circuited | Hardware malfunction | F5 |
| Communication malfunction | Hardware malfunction | E6 |
| Malfunction of phase current detection circuit for compressor | Hardware malfunction | U1 |
| Compressor demagnetization protection | Viewing malfunction code through remote controller within 200s; displayed directly on nixietube after 200s | HE |
| Malfunction of voltage dropping for DC bus-bar | | U3 |
| Module high temperature protection | | P8 |
| Refrigerant lacking or blockage protection of system (not available for residential ODU) | | F0 |
| Charging malfunction of capacitor | Hardware malfunction | PU |
| High pressure protection of system | Hardware malfunction | E1 |
| Low pressure protection of system (reserved) | Hardware malfunction | E3 |

9. Maintenance

| | | |
|---|--|----|
| Compressor overload protection | Viewing malfunction code through remote controller within 200s; displayed directly on nixietube after 200s | H3 |
| Indoor unit and outdoor unit do not match | Hardware malfunction | LP |
| Malfunction of memory chip | Hardware malfunction | EE |
| Wrong connection of communication wire or malfunction of electronic expansion valve | Hardware malfunction | dn |
| Malfunction of complete units current detection | Hardware malfunction | U5 |
| Malfunction protection of outdoor fan 1 | Hardware malfunction | L3 |
| Detection status of wrong connection of communication wire or malfunction of electronic expansion valve | Operation status | dd |
| Mode conflict | Operation status | E7 |
| Refrigerant recycling mode | Operation status | Fo |
| X-fan | Operation status | AL |
| Defrosting or oil return in heating mode | Operation status | H1 |
| Start failure of compressor | Viewing malfunction code through remote controller within 200s; displayed directly on nixietube after 200s | Lc |
| High discharge temperature protection of compressor | | E4 |
| Overload protection | | E8 |
| Whole unit overcurrent protection | | E5 |
| Compressor phase current protection | | P5 |
| Compressor desynchronizing | | H7 |
| Compressor phase-lacking/phase-inverse protection | | Ld |
| IPM modular protection | | H5 |
| DC bus-bar low voltage protection | | PL |
| DC bus-bar high voltage protection | | PH |
| PFC protection | | HC |
| The four-way valve is abnormal | | U7 |

9.3 Malfunction Checking and Elimination

1 IPM protection malfunction:

Main checking point:

- If the input voltage of the unit is within normal range?
- If the connection wire of compressor is connected well? Is it loose? If the connection sequence is correct?
- If the resistance of compressor coil is normal? If the isolation of compressor coil with copper pipe is good?
- If the unit is overloaded? If the heat radiation of the unit is good?
- If the refrigerant charge is suitable?

Flow chart:

9. Maintenance

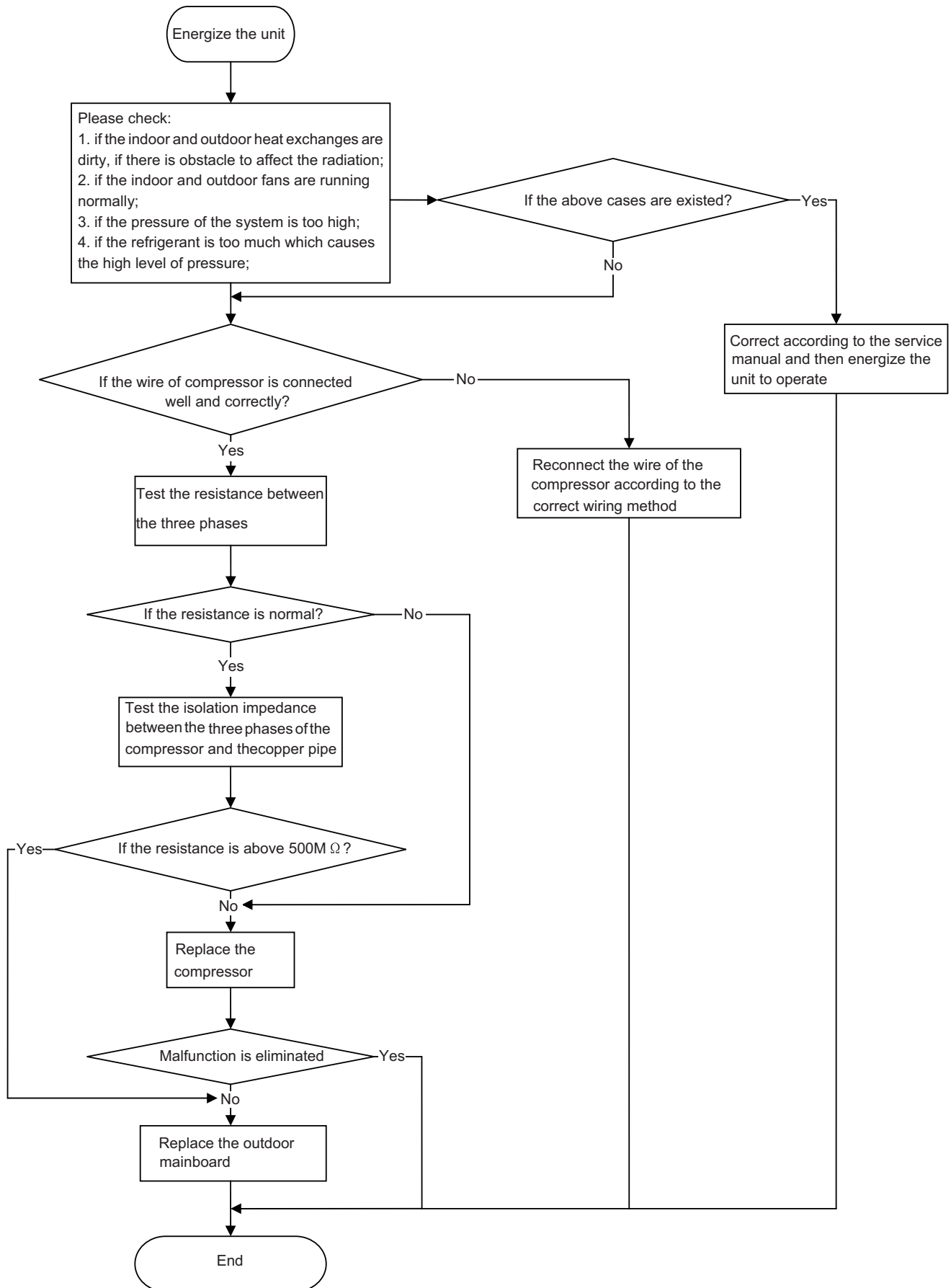

9. Maintenance

2. PFC protection malfunction, capacity charging malfunction

Main checking points:

- If the wiring of the induction is connected well and if the induction is broken;
- If the mainboard is broken;

Flow chart:

For 14/18K

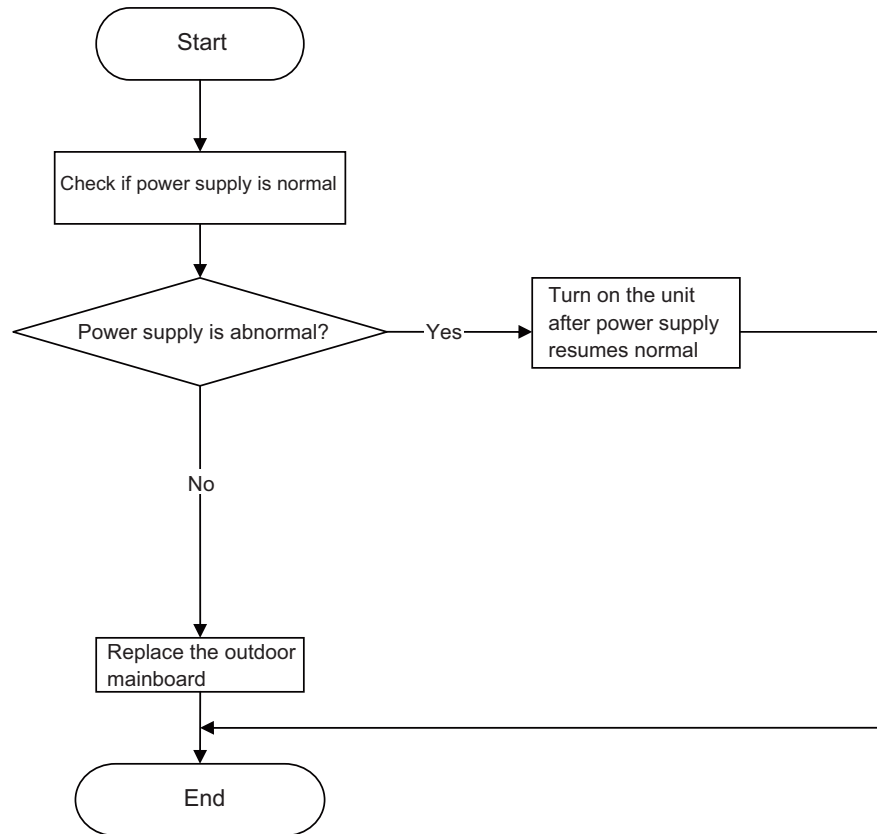

9. Maintenance

3. Compressor desynchronizing malfunction

Main checking points:

- If the pressure of the system is too high;
- If the electric expansion valve is working normally or it is broken;
- If the radiation of the unit is good;

Flow chart:

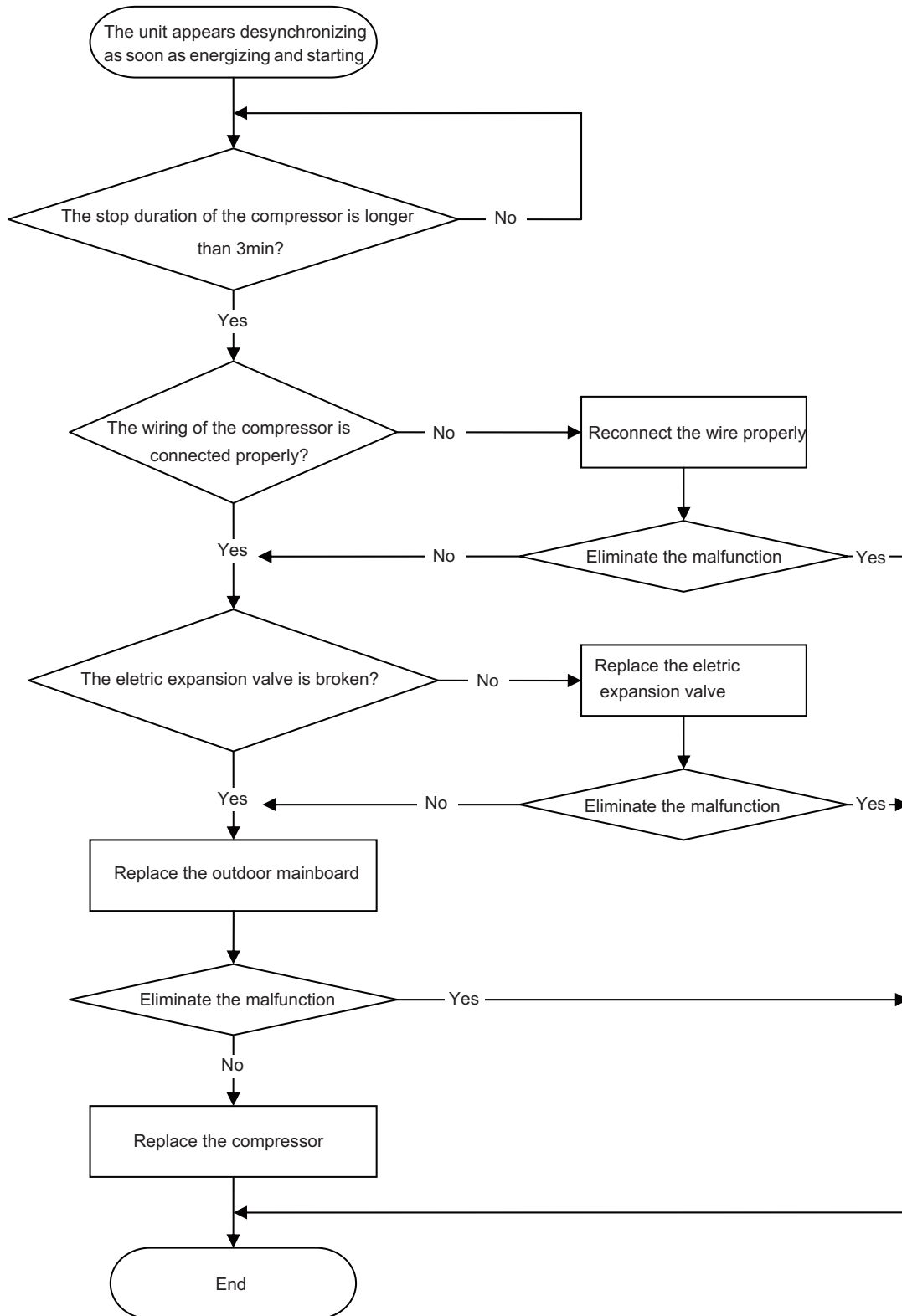

9. Maintenance

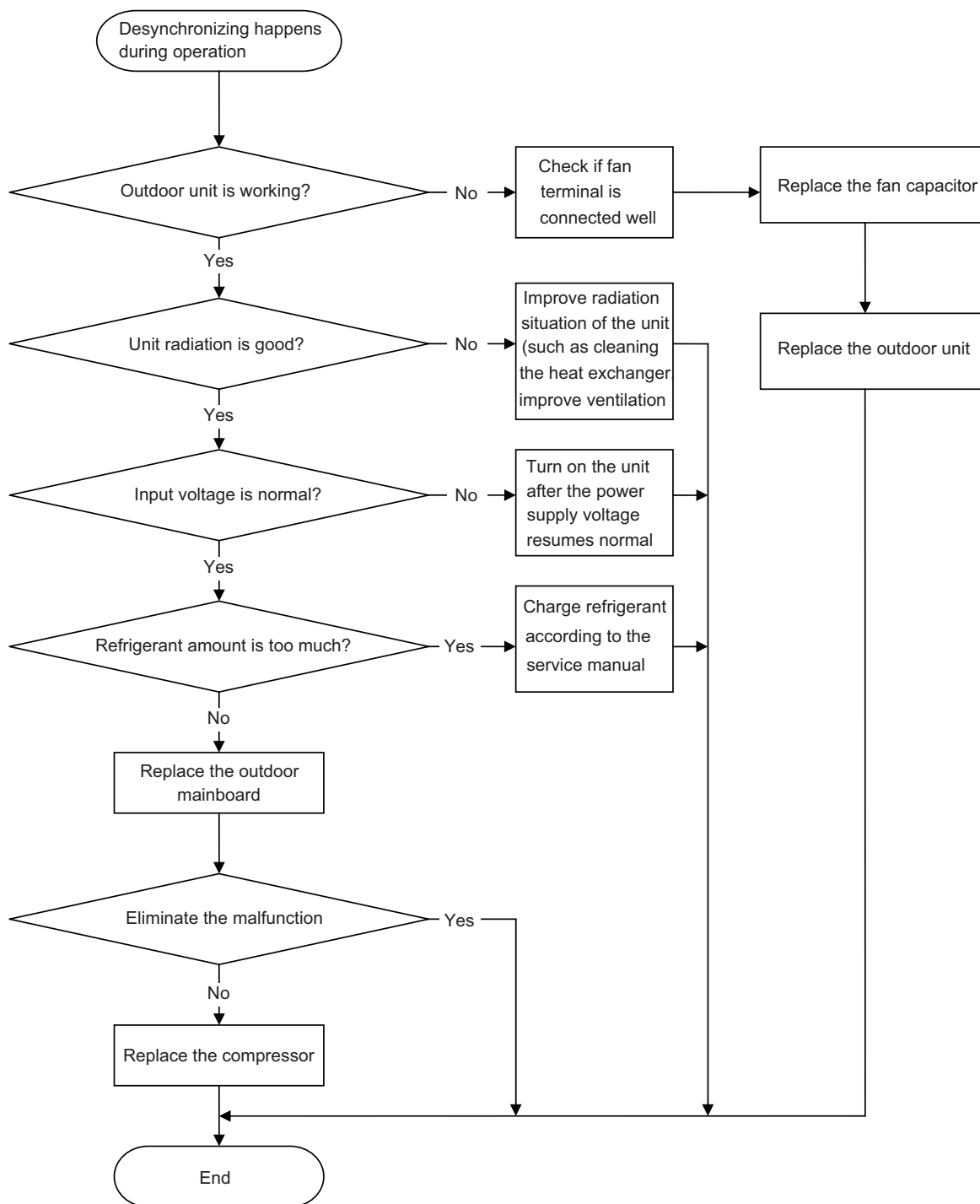

9. Maintenance

4. Compressor overload, discharge protection malfunction

Main checking points:

- If the electric expansion valve is connected well or it is broken;
- If there is refrigerant leakage;
- If the overload protector is broken;

Flow chart:

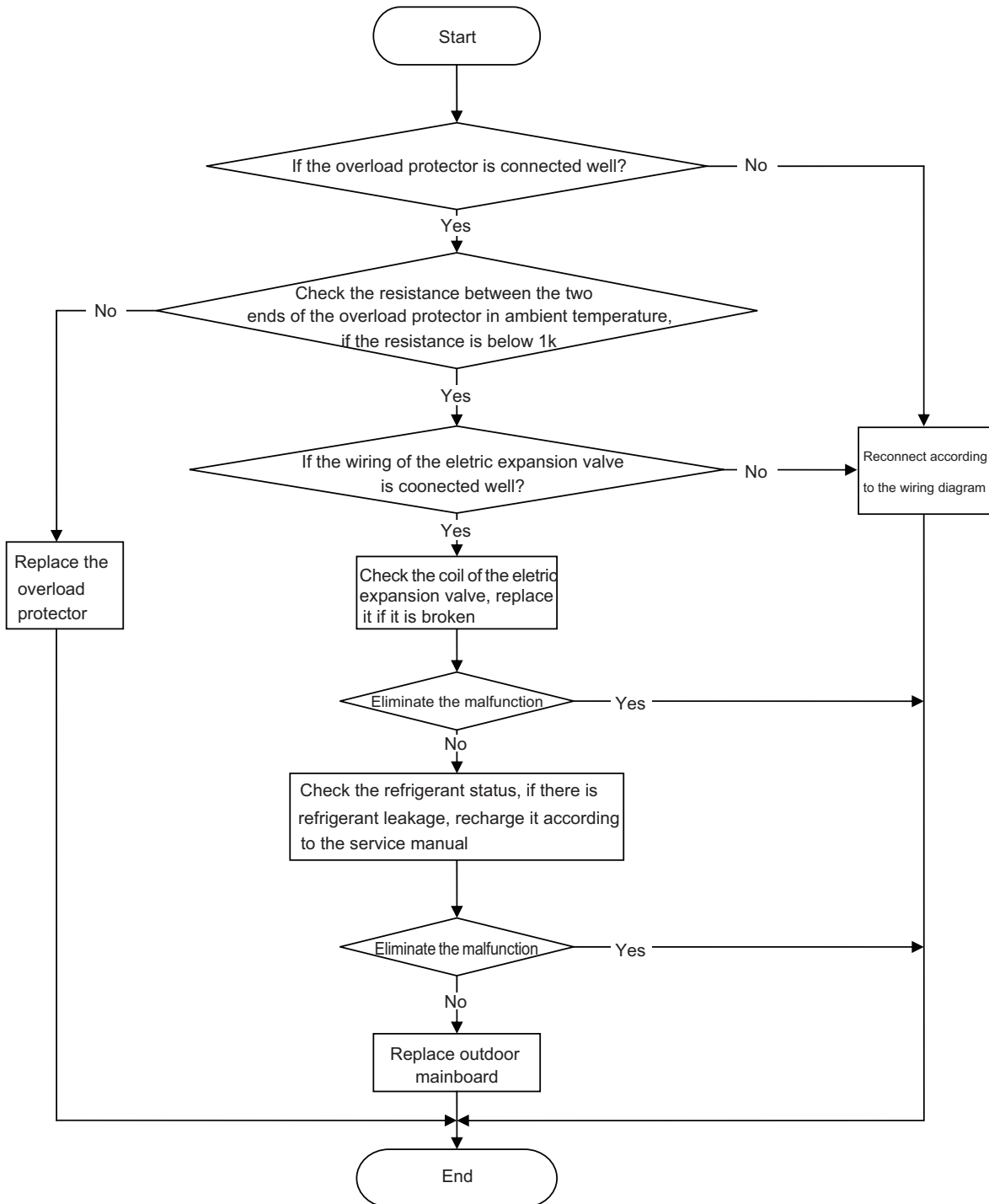

Note: the detection method of the coil of the electric expansion valve: there is five pieces of coil of the electric expansion valve, the resistance of one of them (the leftmost or the rightmost one) is almost the same as the resistance of other terminal (within 100Ω). Judge the condition of the electronic expansion valve through detecting these resistance.

9. Maintenance

5. Start failure/malfunction

Main checking points:

- If the connection wire of the compressor is connected properly;
- If the stop duration of the compressor is sufficient;
- If the compressor is broken;
- If the refrigerant charging amount is too much;

Flow chart:

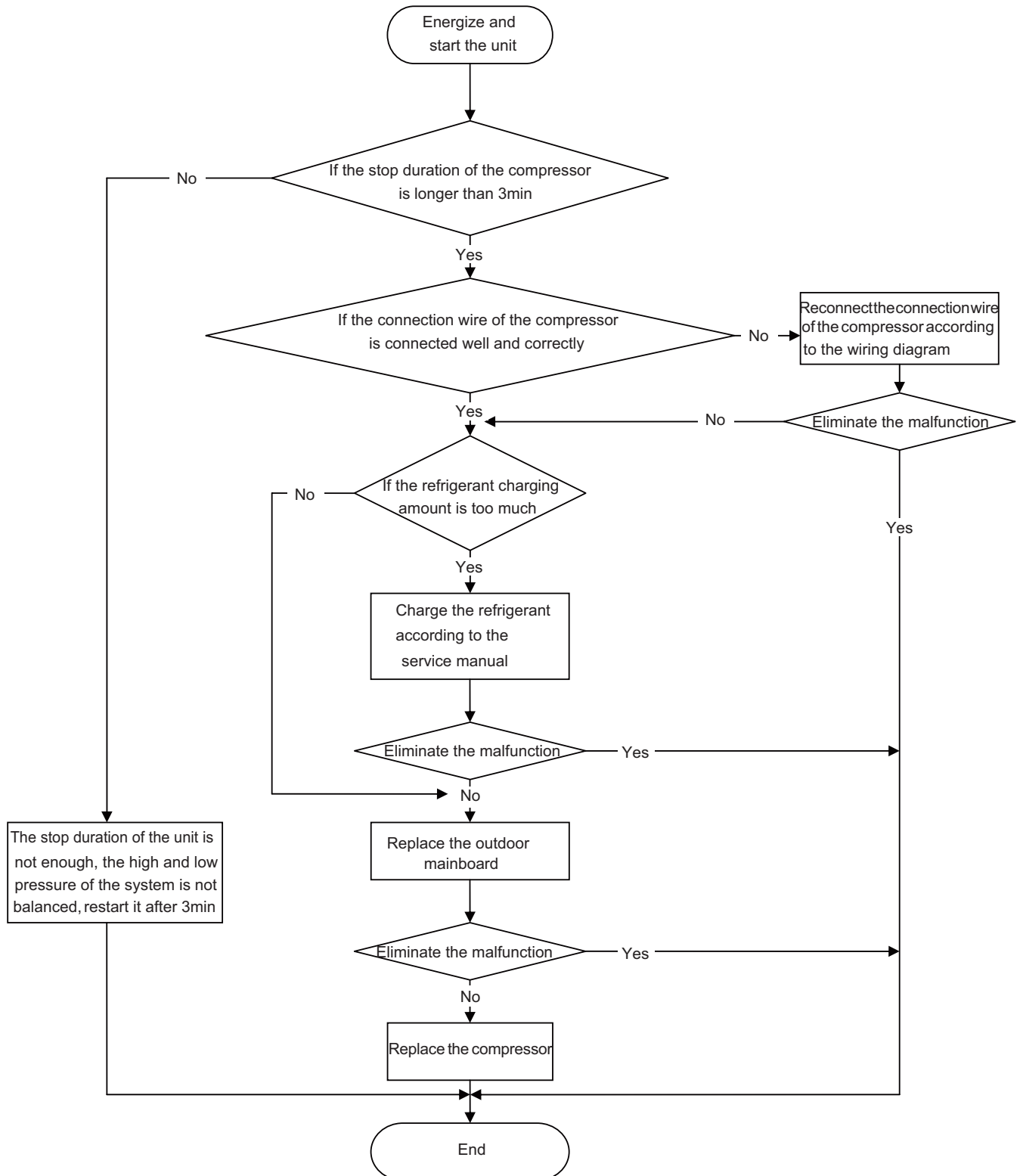

9. Maintenance

6. Temperature sensor malfunction

Main checking points:

- If the temperature sensor is damaged or broken
- If the terminal of the temperature sensor is loosened or not connected;
- If the mainboard is broken;

Flow chart:

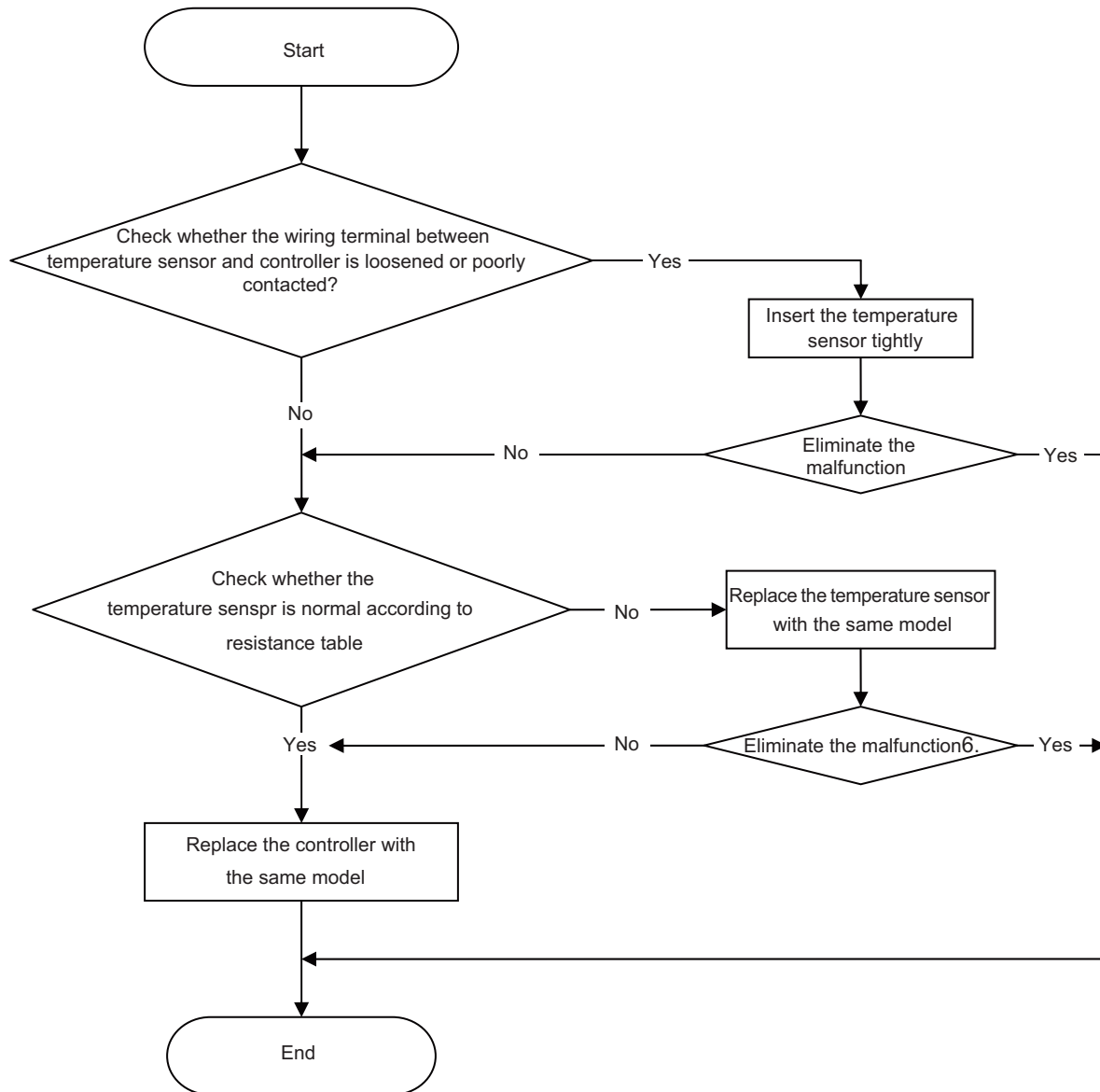

9. Maintenance

7. DC fan malfunction

Main checking points:

- If the outdoor fan is blocked by foreign objects;
- The connection wire of DC fan is connected reliably? If it is loose?

Flow chart:

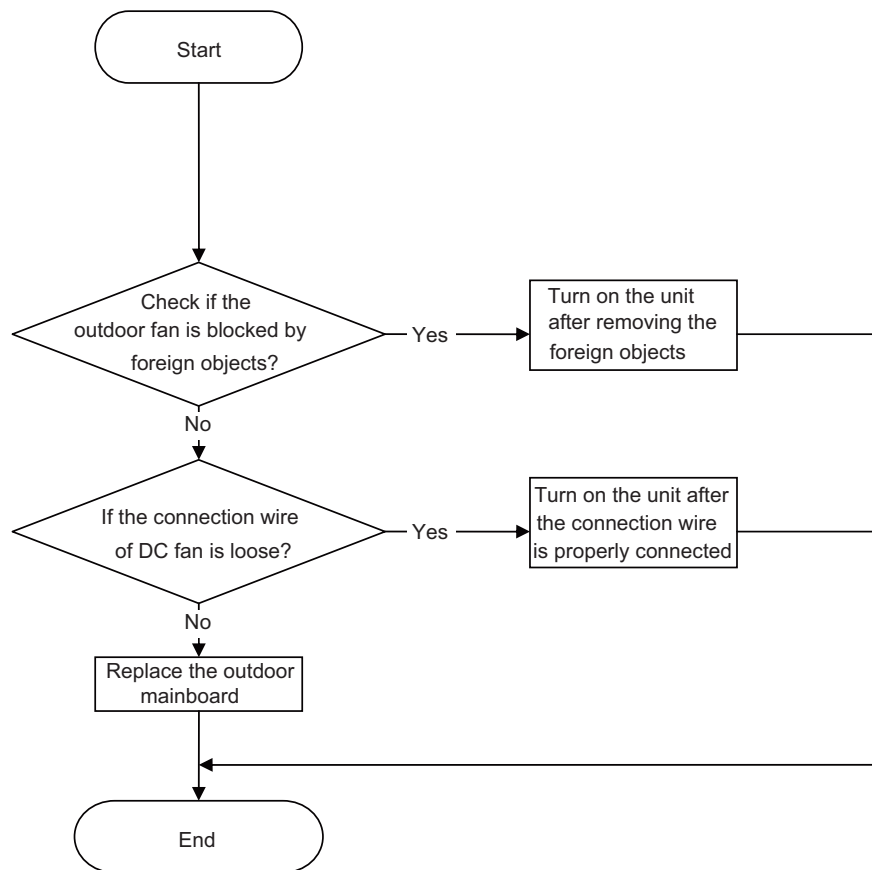

9. Maintenance

8. Communication malfunction

Main checking points:

- If the connection wire between the indoor unit and outdoor unit is connected well, if the wires inside the unit is connected well;
- If the indoor mainboard or outdoor main board is broken;

Flow chart:

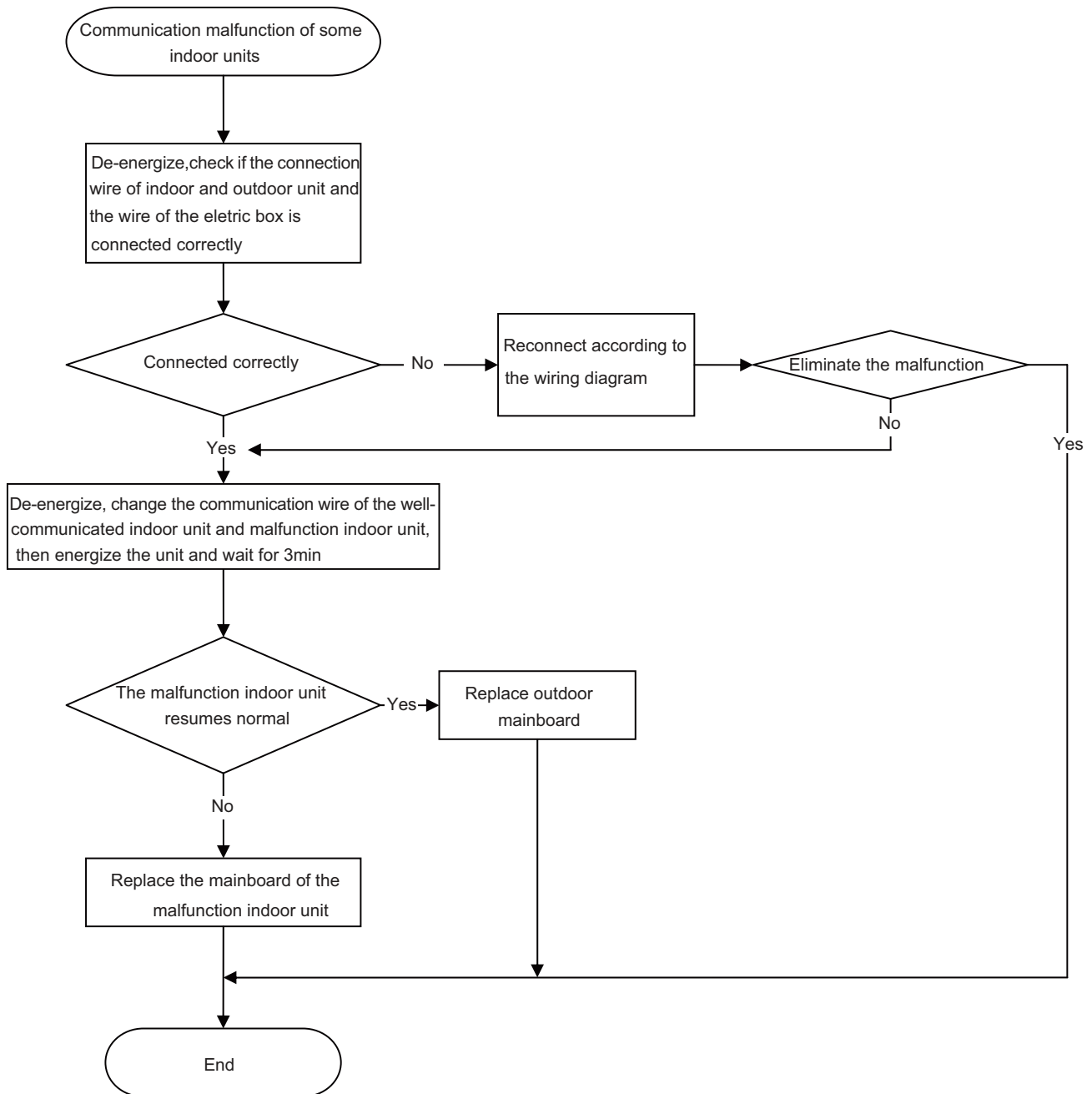

9. Maintenance

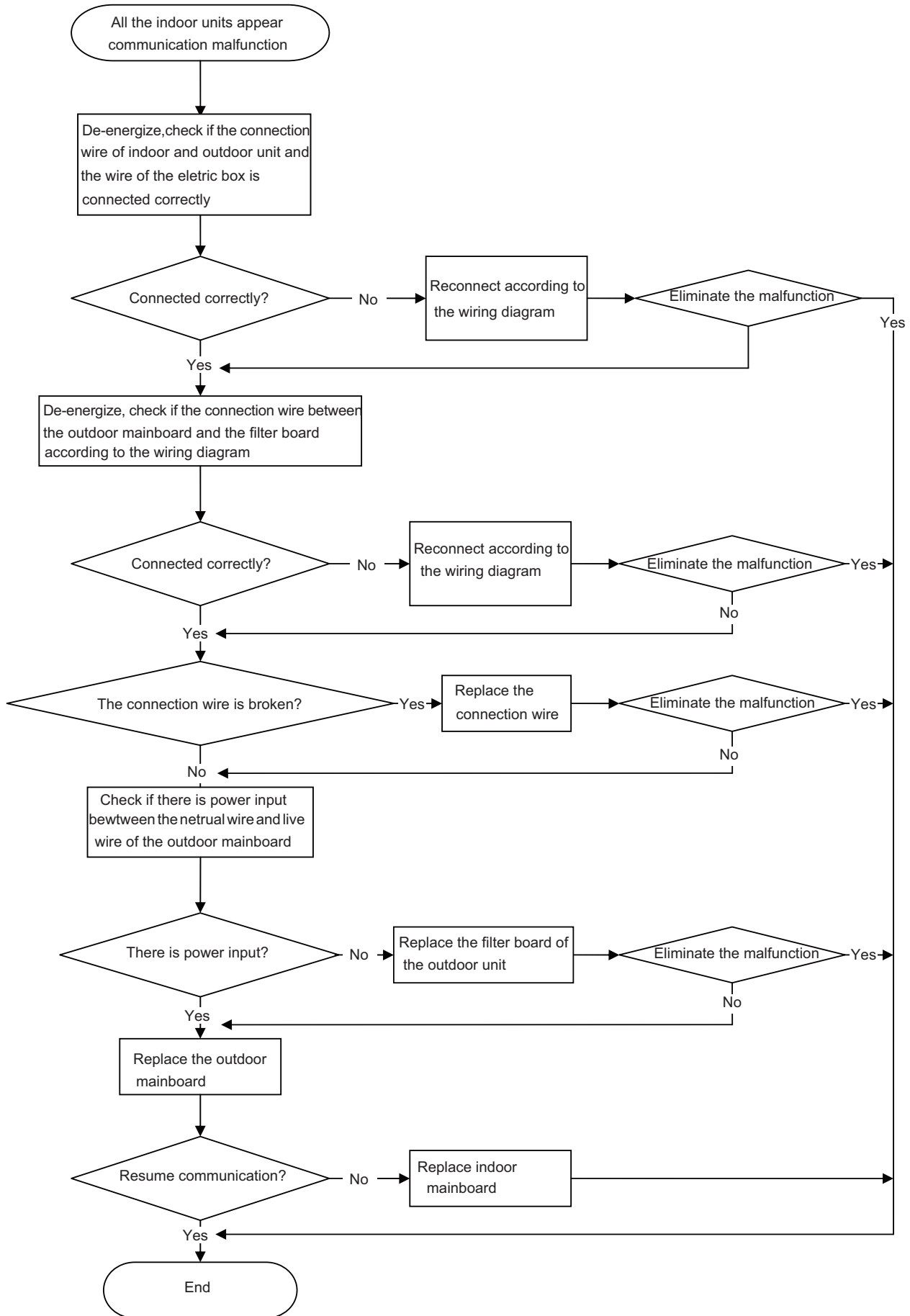

9. Maintenance

9. Anti-high temperature and overload malfunction

Main checking points:

- If the outdoor ambient temperature is within the normal range;
- If the indoor fan and outdoor fan are running normally;
- If the indoor and outdoor radiation environment is good;

Flow chart:

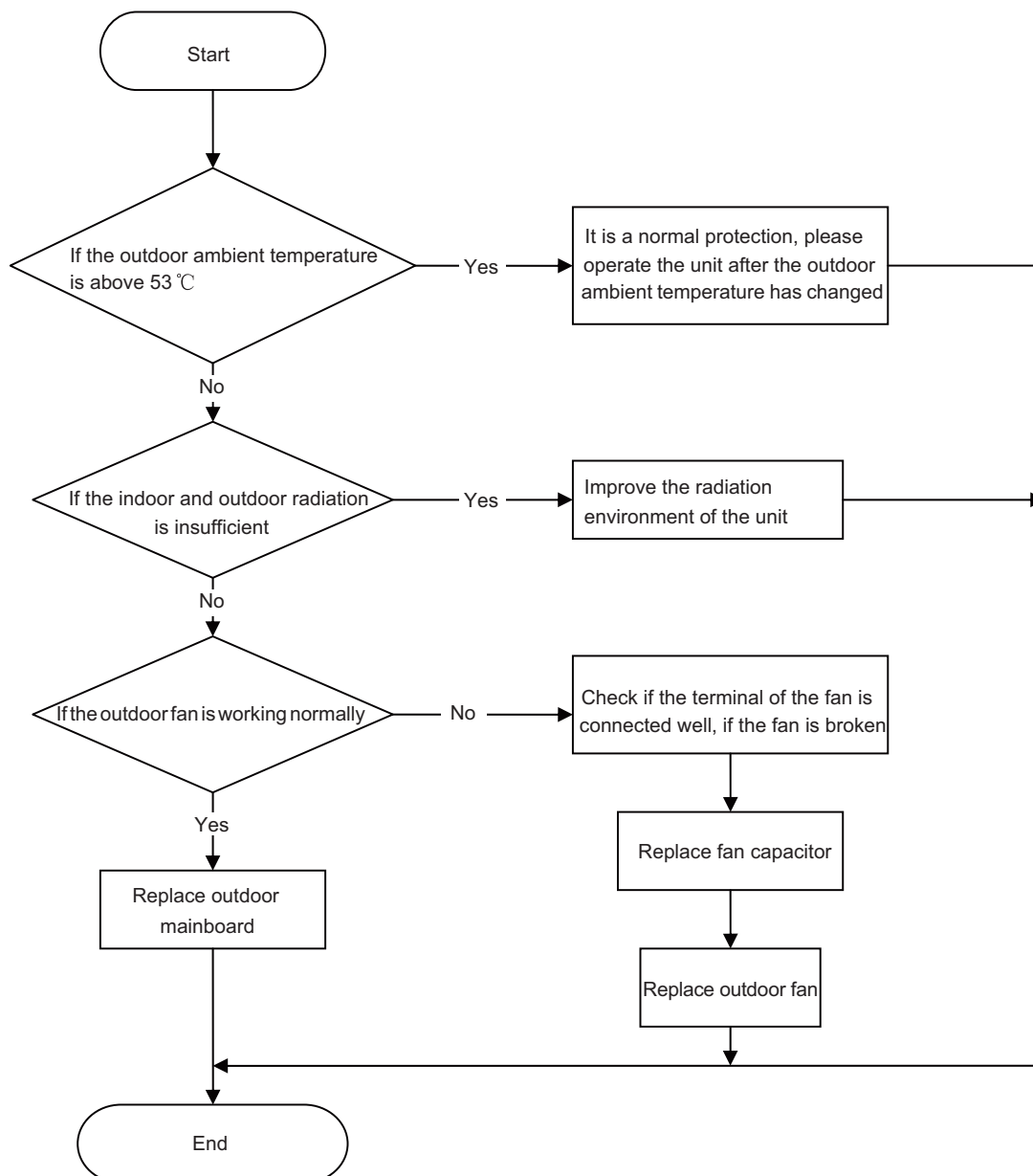

9. Maintenance

9.4 Troubleshooting for Normal Malfunction

1. Air Conditioner Can't be Started Up

| Possible Causes | Discriminating Method (Air conditioner Status) | Troubleshooting |
|---|---|--|
| No power supply, or poor connection for power plug | After energization, operation indicator isn't bright and the buzzer can't give out sound | Confirm whether its due to power failure. If yes, wait for power recovery. If not, check power supply circuit and make sure the power plug is connected well. |
| Wrong wire connection between indoor unit and outdoor unit, or poor connection for wiring terminals | Under normal power supply circumstances, operation indicator isn't bright after energization | Check the circuit according to circuit diagram and connect wires correctly. Make sure all wiring terminals are connected firmly |
| Electric leakage for air conditioner | After energization, room circuit breaker trips off at once | Make sure the air conditioner is grounded reliably Make sure wires of air conditioner is connected correctly Check the wiring inside air conditioner. Check whether the insulation layer of power cord is damaged; if yes, place the power cord. |
| Model selection for air switch is improper | After energization, air switch trips off | Select proper air switch |
| Malfunction of remote controller | After energization, operation indicator is bright, while no display on remote controller or buttons have no action. | Replace batteries for remote controller Repair or replace remote controller |

2. Poor Cooling (Heating) for Air Conditioner

| Possible Causes | Discriminating Method (Air conditioner Status) | Troubleshooting |
|--|---|---|
| Set temperature is improper | Observe the set temperature on remote controller | Adjust the set temperature |
| Rotation speed of the IDU fan motor is set too low | Small wind blow | Set the fan speed at high or medium |
| Filter of indoor unit is blocked | Check the filter to see its blocked | Clean the filter |
| Installation position for indoor unit and outdoor unit is improper | Check whether the installation position is proper according to installation requirement for air conditioner | Adjust the installation position, and install the rainproof and sunproof for outdoor unit |
| Refrigerant is leaking | Discharged air temperature during cooling is higher than normal discharged wind temperature; Discharged air temperature during heating is lower than normal discharged wind temperature; Units pressure is much lower than regulated range | Find out the leakage causes and deal with it. Add refrigerant. |
| Malfunction of 4-way valve | Blow cold wind during heating | Replace the 4-way valve |
| Malfunction of capillary | Discharged air temperature during cooling is higher than normal discharged wind temperature; Discharged air temperature during heating is lower than normal discharged wind temperature; Unit pressure is much lower than regulated range. If refrigerant isn't leaking, part of capillary is blocked | Replace the capillary |
| Flow volume of valve is insufficient | The pressure of valves is much lower than that stated in the specification | Open the valve completely |
| Malfunction of horizontal louver | Horizontal louver can't swing | Refer to point 3 of maintenance method for details |
| Malfunction of the IDU fan motor | The IDU fan motor can't operate | Refer to troubleshooting for H6 for maintenance method in details |
| Malfunction of the ODU fan motor | The ODU fan motor can't operate | Refer to point 4 of maintenance method for details |
| Malfunction of compressor | Compressor can't operate | Refer to point 5 of maintenance method for details |

3. Horizontal Louver Can't Swing

| Possible Causes | Discriminating Method (Air conditioner Status) | Troubleshooting |
|---|--|--|
| Wrong wire connection, or poor connection | Check the wiring status according to circuit diagram | Connect wires according to wiring diagram to make sure all wiring terminals are connected firmly |
| Stepping motor is damaged | Stepping motor can't operate | Repair or replace stepping motor |
| Main board is damaged | Others are all normal, while horizontal louver can't operate | Replace the main board with the same model |

9. Maintenance

4. ODU Fan Motor Can't Operate

| Possible causes | Discriminating method (air conditioner status) | Troubleshooting |
|---|---|--|
| Wrong wire connection, or poor connection | Check the wiring status according to circuit diagram | Connect wires according to wiring diagram to make sure all wiring terminals are connected firmly |
| Capacity of the ODU fan motor is damaged | Measure the capacity of fan capacitor with an universal meter and find that the capacity is out of the deviation range indicated on the nameplate of fan capacitor. | Replace the capacity of fan |
| Power voltage is a little low or high | Use universal meter to measure the power supply voltage. The voltage is a little high or low | Suggest to equip with voltage regulator |
| Motor of outdoor unit is damaged | When unit is on, cooling/heating performance is bad and ODU compressor generates a lot of noise and heat. | Change compressor oil and refrigerant. If no better, replace the compressor with a new one |

5. Compressor Can't Operate

| Possible causes | Discriminating method (air conditioner status) | Troubleshooting |
|---|---|--|
| Wrong wire connection, or poor connection | Check the wiring status according to circuit diagram | Connect wires according to wiring diagram to make sure all wiring terminals are connected firmly |
| Capacity of compressor is damaged | Measure the capacity of fan capacitor with an universal meter and find that the capacity is out of the deviation range indicated on the nameplate of fan capacitor. | Replace the compressor capacitor |
| Power voltage is a little low or high | Use universal meter to measure the power supply voltage. The voltage is a little high or low | Suggest to equip with voltage regulator |
| Coil of compressor is burnt out | Use universal meter to measure the resistance between compressor terminals and its 0 | Repair or replace compressor |
| Cylinder of compressor is blocked | Compressor can't operate | Repair or replace compressor |

6. Air Conditioner is Leaking

| Possible causes | Discriminating method (air conditioner status) | Troubleshooting |
|-----------------------|---|---|
| Drain pipe is blocked | Water leaking from indoor unit | Eliminate the foreign objects inside the drain pipe |
| Drain pipe is broken | Water leaking from drain pipe | Replace drain pipe |
| Wrapping is not tight | Water leaking from the pipe connection place of indoor unit | Wrap it again and bundle it tightly |

7. Abnormal Sound and Vibration

| Possible causes | Discriminating method (air conditioner status) | Troubleshooting |
|--|--|---|
| When turn on or turn off the unit, the panel and other parts will expand and theres abnormal sound | Theres the sound of "PAPA" | Normal phenomenon. Abnormal sound will disappear after a few minutes. |
| When turn on or turn off the unit, theres abnormal sound due to flow of refrigerant inside air conditioner | Water-running sound can be heard | Normal phenomenon. Abnormal sound will disappear after a few minutes. |
| Foreign objects inside the indoor unit or therere parts touching together inside the indoor unit | Theres abnormal sound fro indoor unit | Remove foreign objects. Adjust all parts position of indoor unit, tighten screws and stick damping plaster between connected parts |
| Foreign objects inside the outdoor unit or therere parts touching together inside the outdoor unit | Theres abnormal sound fro outdoor unit | Remove foreign objects. Adjust all parts position of outdoor unit, tighten screws and stick damping plaster between connected parts |
| Short circuit inside the magnetic coil | During heating, the way valve has abnormal electromagnetic sound | Replace magnetic coil |
| Abnormal shake of compressor | Outdoor unit gives out abnormal sound | Adjust the support foot mat of compressor, tighten the bolts |
| Abnormal sound inside the compressor | Abnormal sound inside the compressor | If add too much refrigerant during maintenance, please reduce refrigerant properly. Replace compressor for other circumstances. |

10. Exploded View and Parts List

MV-E14BI2

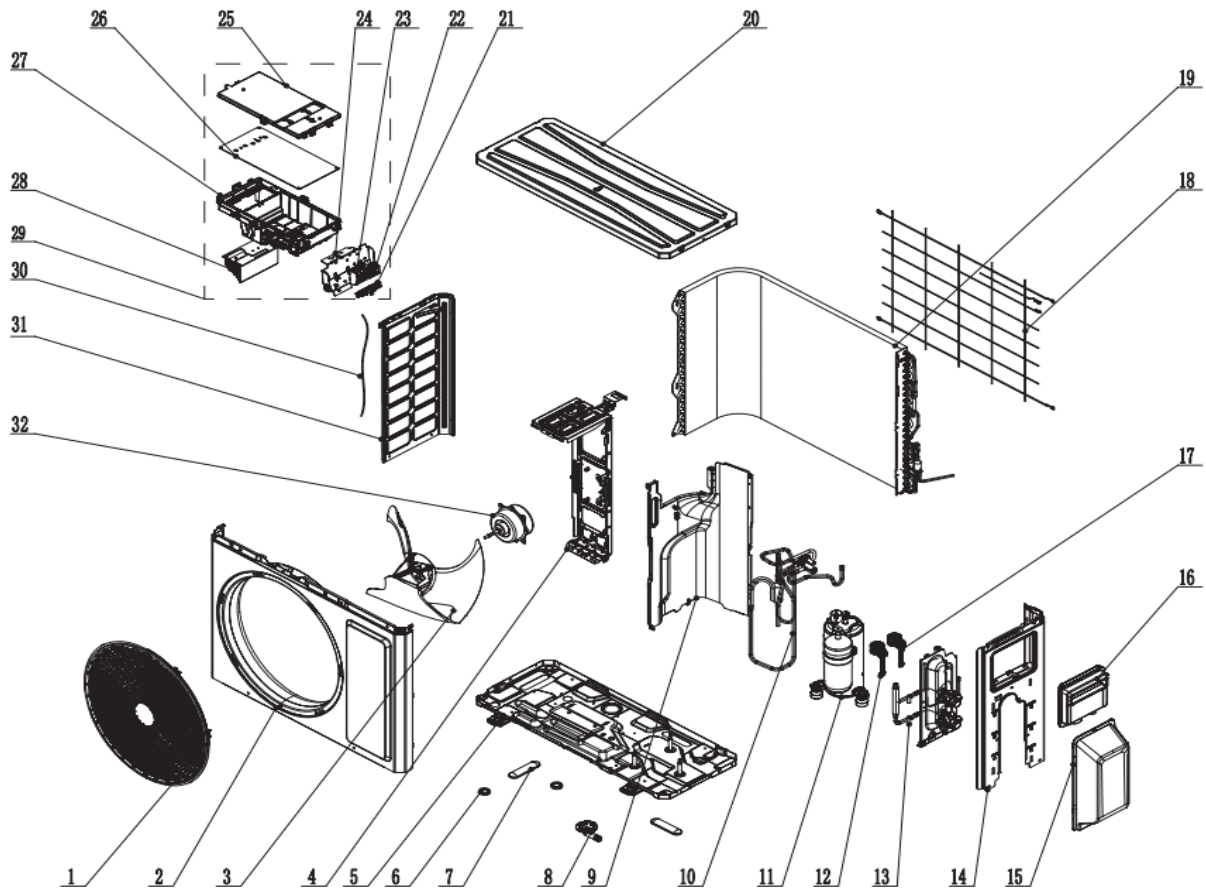

| No | Description | Part Code | Note | Qty | Price Code |
|--------------------------------------|-------------------------------|----------------|------|-----|------------|
| MODEL: MV-E14BI2 Outdoor unit | | | | | |
| 1 | Front Grill | 200057060014 | | 1 | AF |
| 2 | Cabinet | 012022060010P | | 1 | AQ |
| 3 | Axial Flow Fan | 103002060015 | | 1 | AG |
| 4 | Motor Support | 012048060140 | | 1 | AH |
| 5 | Chassis Sub-assy | 017000060690P | | 1 | |
| 6 | Drainage hole Cap | - | | 2 | |
| 7 | Drainage Joint | - | | 2 | |
| 8 | Drainage Connector | 26113009 | | 1 | AD |
| 9 | Clapboard | 012051061336 | | 1 | AK |
| 10 | 4-Way Valve Assy | 030152060672 | | 1 | AW |
| 11 | Compressor and Fittings | 009001060655 | | 1 | BK |
| 12 | Electric Expand Valve Fitting | 07200206002315 | | 1 | AM |
| 13 | Valve Support Sub-Assy | 017104060049P | | 1 | AK |
| 14 | Right Side Plate | - | | 1 | |
| 15 | Valve Cover | - | | 1 | |
| 16 | Cable Cross Plate | - | | 1 | |
| 17 | Electric Expand Valve Fitting | 07200206002309 | | 1 | AM |
| 18 | Rear Grill | 016001060082 | | 1 | AH |
| 19 | Condenser Assy | 011002061524 | | 1 | BE |
| 20 | Top Cover Assy | 000097060355 | | 1 | AP |
| 21 | Wire Clamp | 200015060019 | | 1 | AD |
| 22 | Terminal Board | 422000060016 | | 1 | AG |
| 23 | Terminal Board | - | | | |
| 24 | Terminal Board Support Assy | - | | | |
| 25 | Electric Box cover | - | | | |
| 26 | Main Board | 300027061549 | | 1 | BF |
| 27 | Electric Box | 20001306004701 | | 1 | AK |
| 28 | Radiator | - | | | |
| 29 | Electric Box Assy | 100002071893 | | 1 | |
| 30 | Connecting Cable | - | | | |
| 31 | Left Side Plate | 012055060395P | | 1 | |
| 32 | Brushless DC Motor | 1501308534 | | 1 | AU |
| / | Sensor Sub-assy | 390002060125 | | 1 | AK |
| / | Handle | 200149060019 | | 1 | AE |
| / | Cut off Valve 1/4 | 7130239 | | 1 | AG |
| / | Cut off Valve 3/8 | 71302391 | | 1 | AM |
| / | Temperature Sensor | 3900030905 | | 1 | AK |
| / | Compressor Gasket | 9012000026 | | 1 | |
| / | Bottom chassis heater | 7651000423 | | 1 | |
| | | | | | |

The data are subject to change without notice.

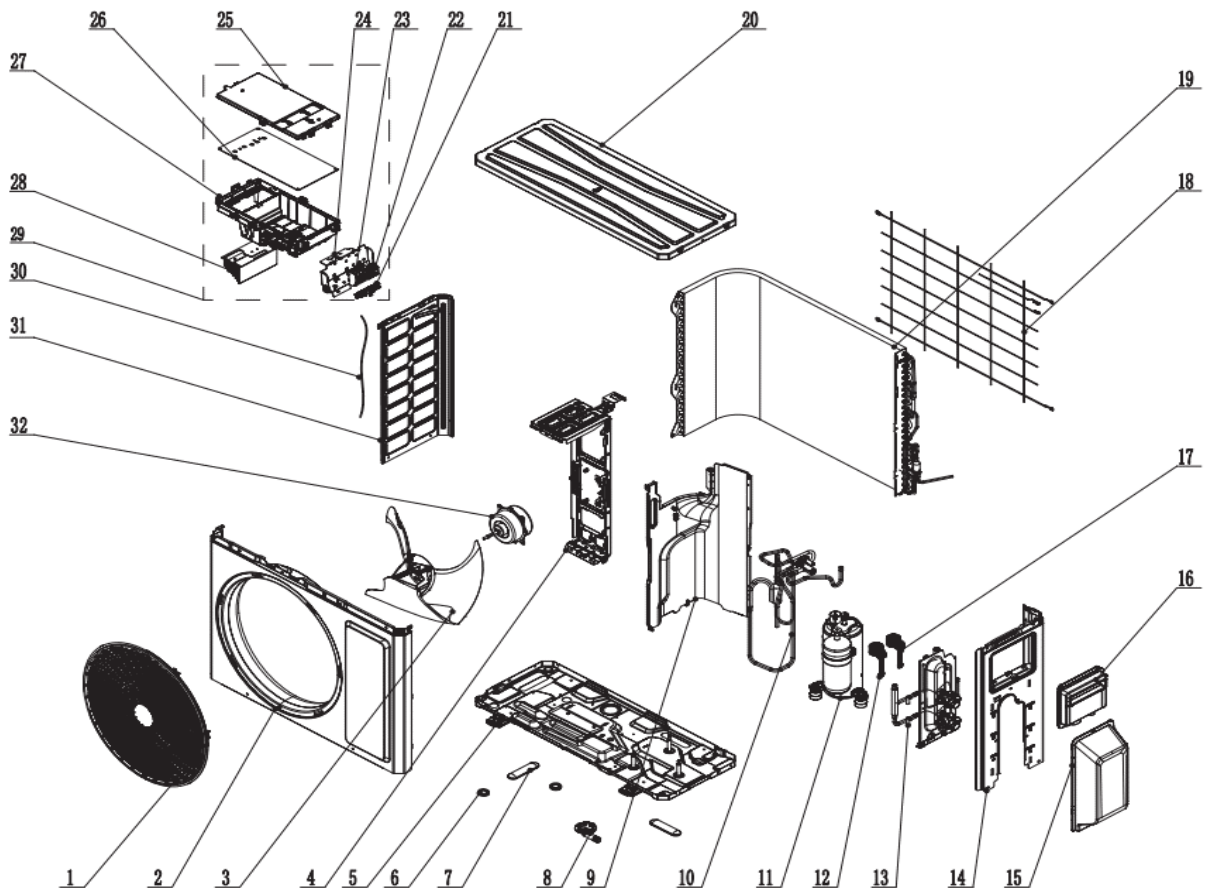

| No | Description | Part Code | Note | Qty | Price Code |
|--------------------------------------|-------------------------------|---------------|------|-----|------------|
| MODEL: MV-E18BI2 Outdoor unit | | | | | |
| 1 | Front Grill | 200057060014 | | 1 | AF |
| 2 | Cabinet | - | | 1 | |
| 3 | Axial Flow Fan | 103002060015 | | 1 | AG |
| 4 | Motor Support | 46060146 | | 1 | |
| 5 | Chassis Sub-assy | 017000060690P | | 1 | |
| 6 | Drainage hole Cap | - | | 2 | |
| 7 | Drainage Joint | 26113009 | | 2 | AD |
| 8 | Drainage Connector | - | | 1 | |
| 9 | Clapboard | 012051061336 | | 1 | AK |
| 10 | 4-Way Valve Assy | 030152060672 | | 1 | AW |
| 11 | Compressor and Fittings | 9001060656 | | 1 | BH |
| 12 | Electric Expand Valve Fitting | 72009060033 | | 1 | AP |
| 13 | Valve Support Sub-Assy | 017104060049P | | 1 | AK |
| 14 | Right Side Plate | 012056060396P | | 1 | |
| 15 | Valve Cover | - | | 1 | |
| 16 | Cable Cross Plate | - | | 1 | |
| 17 | Magnet Coil | 4300040078 | | 1 | AK |
| 18 | Rear Grill | 016001060082 | | 1 | AH |
| 19 | Condenser Assy | 011002061589 | | 1 | BK |
| 20 | Top Cover Assy | 012049060107P | | 1 | |
| 21 | Wire Clamp | 200015060019 | | 1 | AD |
| 22 | Terminal Board | 422000060016 | | 1 | AG |
| 23 | Terminal Board | - | | | |
| 24 | Terminal Board Support Assy | - | | | |
| 25 | Electric Box cover | - | | | |
| 26 | Main Board | 300027061550 | | 1 | BF |
| 27 | Electric Box | 200013060047 | | 1 | |
| 28 | Radiator | - | | | |
| 29 | Electric Box Assy | 100002071901 | | 1 | |
| 30 | Connecting Cable | - | | | |
| 31 | Left Side Plate | - | | 1 | |
| 32 | Brushless DC Motor | 1501308534 | | 1 | AU |
| / | Handle | 200149060019 | | 1 | AE |
| / | Cut off Valve 1/4 | 7130239 | | 1 | AG |
| / | Cut off Valve 3/8 | 71302391 | | 1 | AM |
| / | Front Panel Assy | 3060534 | | 1 | |
| / | Bottom chassis heater | 7651000423 | | 1 | |
| | | | | | |
| | | | | | |

The data are subject to change without notice.

MV-E21BI2

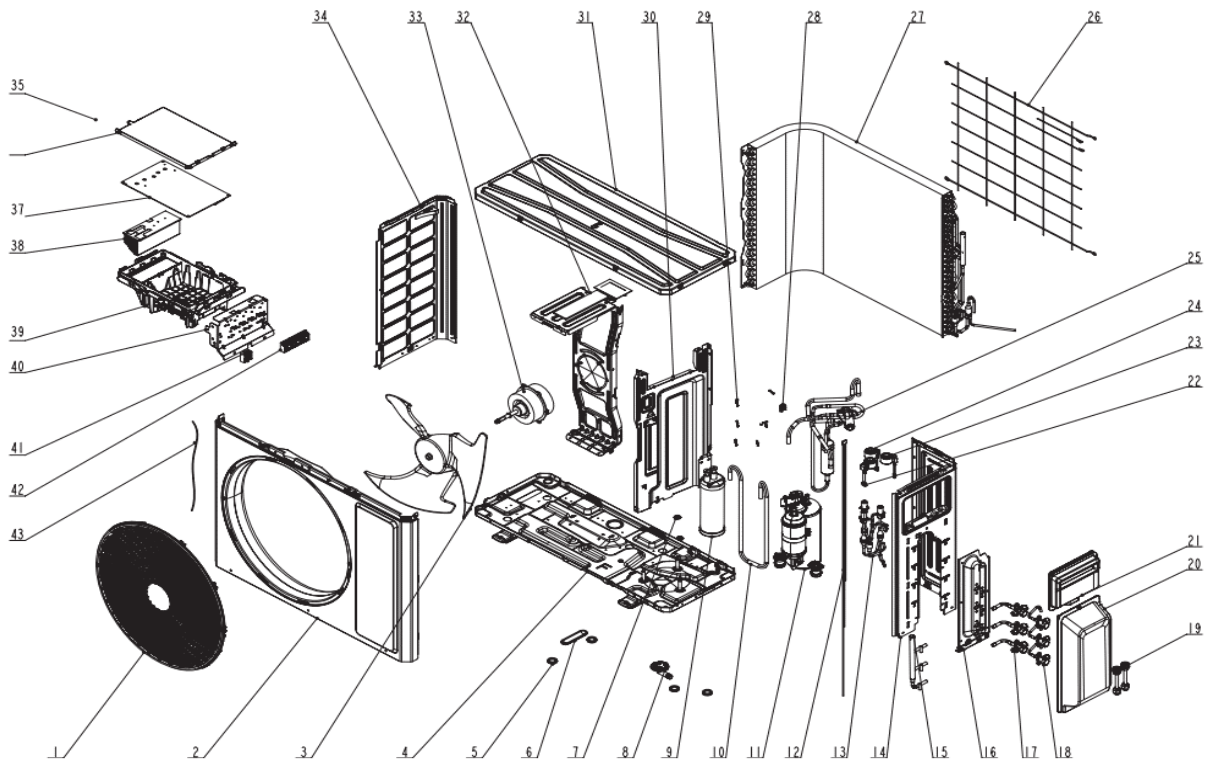

| No | Description | Part Code | Note | Qty | Price Code |
|--------------------------------------|---------------------------------|----------------|------|-----|------------|
| MODEL: MV-E21B12 Outdoor unit | | | | | |
| 1 | Front Grill | 200057060016 | | 1 | AG |
| 2 | Front Panel | 012073061611P | | 1 | |
| 3 | Axial Flow Fan | 10335262 | | 1 | AL |
| 4 | Chassis Sub-assy | 017000060715P | | 1 | |
| 5 | Drainage hole Cap | 06813401 | | 4 | AB |
| 6 | Drainage hole Cap | 06813401 | | 4 | AB |
| 7 | Compressor Gasket | - | | | |
| 8 | Drainage Joint | 26113009 | | 1 | AD |
| 9 | Gas-liquid Separator | 07223048 | | 1 | AU |
| 10 | Inhalation Tube | 035006062512 | | 1 | |
| 11 | Compressor and Fittings | 00900106061701 | | 1 | BL |
| 12 | Temperature Sensor | - | | | |
| 13 | Electronic Expansion Valve assy | 030174060163 | | 1 | AZ |
| 14 | Right Side Plate | 012056060436P | | 1 | AP |
| 15 | Gas Separator Sub-assy | - | | | |
| 16 | Valve Support Sub-assy | 017104060050P | | 1 | |
| 17 | Cut-off valve Sub-assy 3/8 | 071302391 | | 1 | AM |
| 18 | Cut-off valve Sub-assy 1/4 | 07130239 | | 1 | AG |
| 19 | Tube Connector Sub-assy | - | | | |
| 20 | Valve Cover | 200087060007 | | 1 | AE |
| 21 | Cable Cross Plate | - | | | |
| 22 | Electric Expand Valve Fitting | 07200206002312 | | 1 | AM |
| 23 | Electric Expand Valve Fitting | 07200206002326 | | 1 | AM |
| 24 | Electric Expand Valve Fitting | 07200206002327 | | 1 | AM |
| 25 | 4-Way Valve Assy | 030152060678 | | 1 | AX |
| 26 | Rear Grill | 016001060085 | | 1 | |
| 27 | Condenser Assy | 011002061647 | | 1 | BN |
| 28 | Sensor Clamp | - | | | |
| 29 | Sensor Insert | - | | | |
| 30 | Clapboard Sub-Assy | 017021060671 | | 1 | |
| 31 | Top Cover Assy | 00009706033301 | | 1 | AR |
| 32 | Motor Support | 012048060145 | | 1 | |
| 33 | Brushless DC Motor | 1501506409 | | 1 | AZ |
| 34 | Left Side Plate | 012055060393P | | 1 | AM |
| 35 | Electric Box Assy | 100002071705 | | 1 | |
| 36 | Electric Box Cover | - | | | |
| 37 | Main Board | 300027061732 | | 1 | BH |
| 38 | Radiator | - | | | |
| 39 | Electric Box | - | | | |
| 40 | Terminal Board Support Assy | - | | | |
| 41 | Terminal Board | - | | | |
| 42 | Terminal Board | - | | | |
| 43 | Connecting Cable | - | | | |
| / | Electrical Heater | 765100049 | | 1 | AM |
| / | Left Handle | 000223000018 | | 1 | AF |
| / | Temperature Sensor | 3900007316 | | 1 | AG |
| / | Temperature Sensor | 3900007319 | | 1 | AK |
| / | Temperature Sensor | 3900007317 | | 1 | AG |
| / | Magnet Coil | 4300040087 | | 1 | AH |
| / | Temperature Sensor | 3900030901 | | 1 | AH |
| / | Bottom chassis heater | 765100049 | | 1 | |
| | | | | | |
| | | | | | |

The data are subject to change without notice.

MV-E24BI2

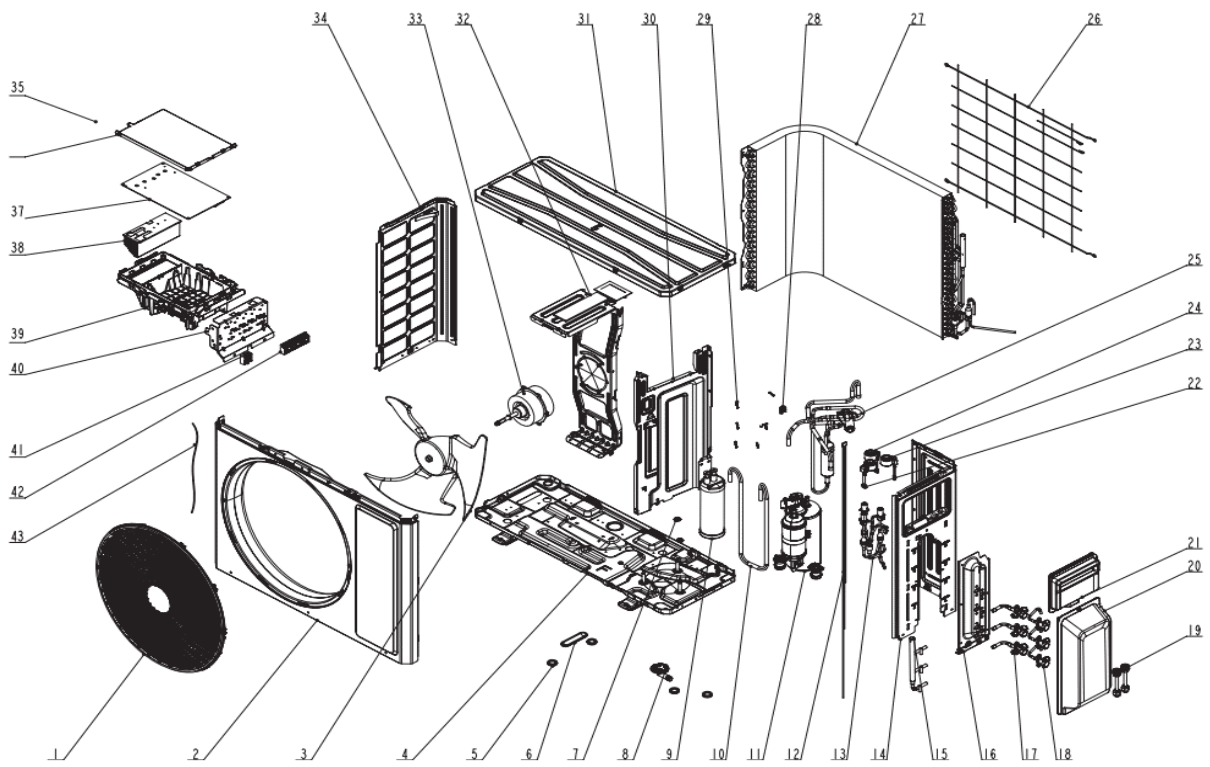

| No | Description | Part Code | Note | Qty | Price Code |
|--------------------------------------|---------------------------------|----------------|------|-----|------------|
| MODEL: MV-E24BI2 Outdoor unit | | | | | |
| 1 | Front Grill | 200057060016 | | 1 | AG |
| 2 | Front Panel | 012073061611P | | 1 | |
| 3 | Axial Flow Fan | 10335262 | | 1 | AL |
| 4 | Chassis Sub-assy | 017000060715P | | 1 | |
| 5 | Drainage hole Cap | 06813401 | | 4 | AB |
| 6 | Drainage hole Cap | 06813401 | | 4 | AB |
| 7 | Compressor Gasket | - | | | |
| 8 | Drainage Joint | 26113009 | | 1 | AD |
| 9 | Gas-liquid Separator | 07223048 | | 1 | AU |
| 10 | Inhalation Tube Sub-assy | 030010061589 | | 1 | AP |
| 11 | Compressor and Fittings | 009001060621 | | 1 | BN |
| 12 | Temperature Sensor | - | | | |
| 13 | Electronic Expansion Valve assy | 030174060163 | | 1 | AZ |
| 14 | Right Side Plate | 012056060436P | | 1 | AP |
| 15 | Gas Separator Sub-assy | - | | | |
| 16 | Valve Support Sub-assy | 030163060029 | | 1 | |
| 17 | Cut-off valve Sub-assy 3/8 | 071302391 | | 1 | AM |
| 18 | Cut-off valve Sub-assy 1/4 | 07130239 | | 1 | AG |
| 19 | Tube Connector Sub-assy | - | | | |
| 20 | Valve Cover | 200087060007 | | 1 | AE |
| 21 | Cable Cross Plate | - | | | |
| 22 | Electric Expand Valve Fitting | 07200206002312 | | 1 | AM |
| 23 | Electric Expand Valve Fitting | 07200206002326 | | 1 | AM |
| 24 | Electric Expand Valve Fitting | 07200206002327 | | 1 | AM |
| 25 | 4-Way Valve Assy | 030152060695 | | 1 | AX |
| 26 | Rear Grill | 016001060085 | | 1 | |
| 27 | Condenser Assy | 011002061647 | | 1 | BN |
| 28 | Sensor Clamp | - | | | |
| 29 | Sensor Insert | - | | | |
| 30 | Clapboard Sub-Assy | 017021060671 | | 1 | |
| 31 | Top Cover Assy | 00009706033301 | | 1 | AR |
| 32 | Motor Support | 012048060145 | | 1 | |
| 33 | Brushless DC Motor | 1501506409 | | 1 | AZ |
| 34 | Left Side Plate | 012055060393P | | 1 | AM |
| 35 | Electric Box Assy | 100002072537 | | 1 | |
| 36 | Electric Box Cover | - | | | |
| 37 | Main Board | 300027061734 | | 1 | BH |
| 38 | Radiator | - | | | |
| 39 | Electric Box | - | | | |
| 40 | Terminal Board Support Assy | - | | | |
| 41 | Terminal Board | - | | | |
| 42 | Terminal Board | - | | | |
| 43 | Connecting Cable | - | | | |
| / | Electrical Heater | 765100049 | | 1 | AM |
| / | Left Handle | 000223000018 | | 1 | AF |
| / | Temperature Sensor | 3900007316 | | 1 | AG |
| / | Temperature Sensor | 3900007319 | | 1 | AK |
| / | Temperature Sensor | 3900007317 | | 1 | AG |
| / | Magnet Coil | 4300040087 | | 1 | AH |
| / | Temperature Sensor | 3900030901 | | 1 | AH |
| / | Bottom chassis heater | 765100049 | | 1 | |
| | | | | | |
| | | | | | |

The data are subject to change without notice.

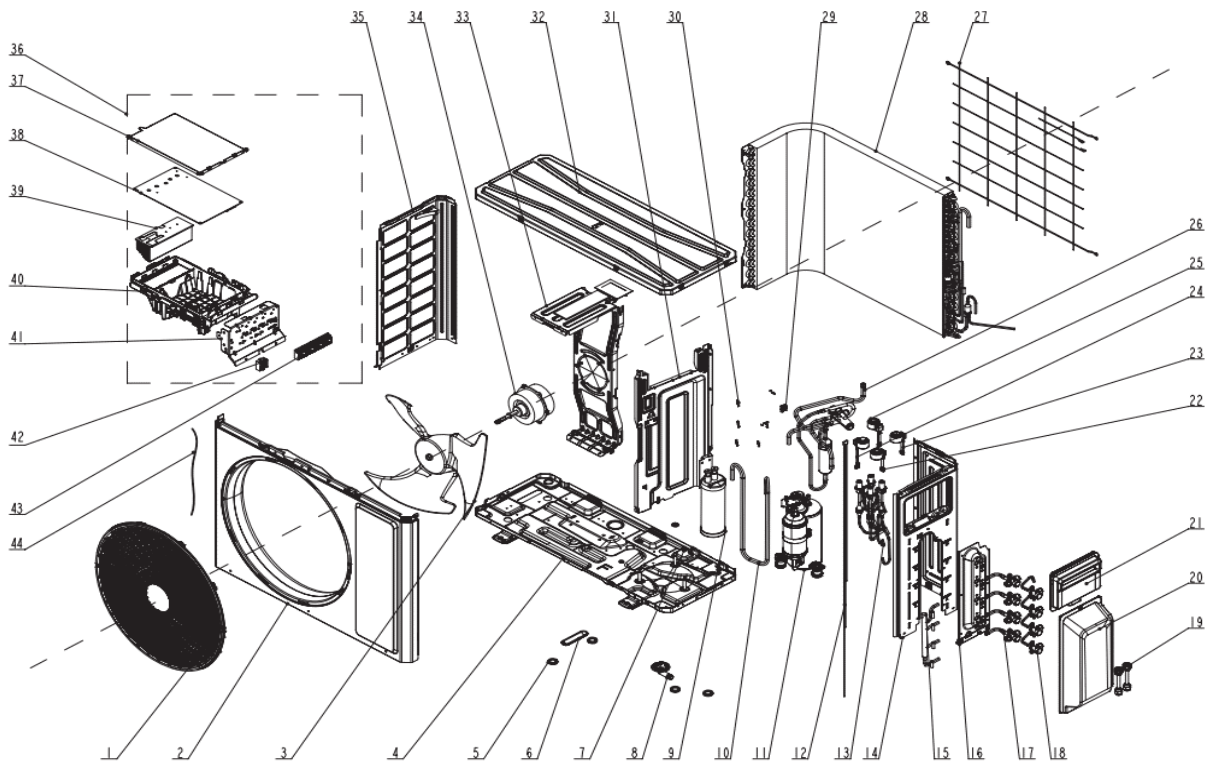

| No | Description | Part Code | Note | Qty | Price Code |
|--------------------------------------|---------------------------------|----------------|------|-----|------------|
| MODEL: MV-E28BI2 Outdoor unit | | | | | |
| 1 | Front Grill | 200057060016 | | 1 | AG |
| 2 | Front Panel | 012073061611P | | 1 | |
| 3 | Axial Flow Fan | 10335262 | | 1 | AL |
| 4 | Chassis Sub-assy | 017000060725P | | 1 | |
| 5 | Drainage hole Cap | 06813401 | | 4 | AB |
| 6 | Drainage hole Cap | - | | | |
| 7 | Compressor Gasket | - | | | |
| 8 | Drainage Joint | 26113009 | | 1 | AD |
| 9 | Gas-liquid Separator | 07223048 | | 1 | AU |
| 10 | Inhalation Tube Sub-assy | 035006062539 | | 1 | |
| 11 | Compressor and Fittings | 00900106060301 | | 1 | BP |
| 12 | Temperature Sensor | 3900030901 | | 1 | AH |
| 13 | Electronic Expansion Valve assy | 030174060172 | | 1 | BA |
| 14 | Right Side Plate | 012056060436P | | 1 | AP |
| 15 | Gas Separator Sub-assy | - | | | |
| 16 | Valve Support Sub-assy | 017104060051P | | 1 | |
| 17 | Cut-off valve Sub-assy 3/8 | 071302391 | | 1 | AM |
| 18 | Cut-off valve Sub-assy 1/4 | 07130239 | | 1 | AG |
| 19 | Tube Connector Sub-assy | - | | | |
| 20 | Valve Cover | 200087060007 | | 1 | AE |
| 21 | Cable Cross Plate | - | | | |
| 22 | Electric Expand Valve Coil | - | | | |
| 23 | Electric Expand Valve Fitting | 07200206002324 | | 1 | AM |
| 24 | Electric Expand Valve Fitting | 07200206002325 | | 1 | AM |
| 25 | Electric Expand Valve Coil | - | | | |
| 26 | 4-Way Valve Assy | 030152060698 | | 1 | AX |
| 27 | Rear Grill | 016001060085 | | 1 | |
| 28 | Condenser Assy | 011002061648 | | 1 | BP |
| 29 | Sensor Clamp | - | | | |
| 30 | Sensor Insert | - | | | |
| 31 | Clapboard Sub-Assy | 017021060671 | | 1 | |
| 32 | Top Cover Assy | 00009706033301 | | 1 | AR |
| 33 | Motor Support | 012048060145 | | 1 | |
| 34 | Brushless DC Motor | 1501506409 | | 1 | AZ |
| 35 | Left Side Plate | 012055060393P | | 1 | AM |
| 36 | Electric Box Assy | 100002071827 | | 1 | |
| 37 | Electric Box Cover | - | | | |
| 38 | Main Board | 300027061733 | | 1 | BH |
| 39 | Radiator | - | | | |
| 40 | Electric Box | - | | | |
| 41 | Terminal Board Support Assy | - | | | |
| 42 | Terminal Board | - | | | |
| 43 | Terminal Board | - | | | |
| 44 | Connecting Cable | - | | | |
| / | Temperature Sensor | 3900007316 | | 1 | AG |
| / | Temperature Sensor | 3900007319 | | 1 | AK |
| / | Temperature Sensor | 3900007317 | | 1 | AG |
| / | Magnet Coil | 4300040071 | | 1 | AK |
| / | Electrical Heater | 765100049 | | 1 | AM |
| / | Left Handle | 000223000018 | | 1 | AF |
| / | Electric Expand Valve Fitting | 07200206002318 | | 1 | AM |
| / | Bottom chassis heater | 765100049 | | 1 | |

The data are subject to change without notice.

MV-E36BI2

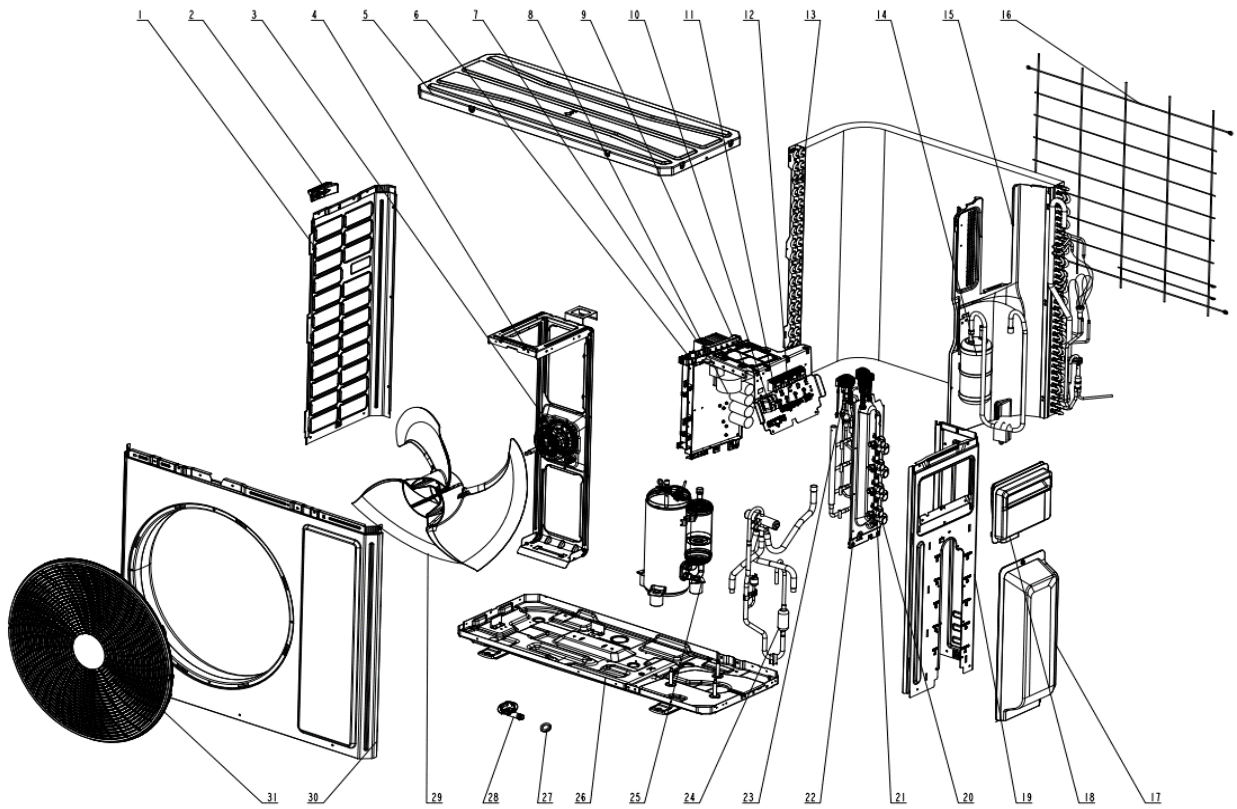

| No | Description | Part Code | Note | Qty | Price Code |
|-------------------------|---------------------------------|----------------|------|-----|------------|
| MODEL: MV-E36BI2 | | | | | |
| 1 | Left Side Plate | 012055060419P | | 1 | |
| 2 | Handle | 26233053 | | 1 | |
| 3 | Brushless DC Motor | 15010406011801 | | 1 | |
| 4 | Motor Support Sub-Assy | 017012060353 | | 1 | |
| 5 | Top cover | 012049060148P | | 1 | |
| 6 | Electric Box Assy | 100002075584 | | 1 | |
| 7 | Radiator | 430034060159 | | 1 | |
| 8 | Main Board | 300027062550 | | 1 | |
| 9 | Filter Board | 300020060099 | | 1 | |
| 10 | Terminal Board | 422000060012 | | 1 | |
| 11 | Terminal Board | 422000060015 | | 4 | |
| 12 | Wire Clamp | 200015060018 | | 1 | |
| 13 | Condenser Assy | 011002062063 | | 1 | |
| 14 | Gas-liquid Separator Assy | 07225017 | | 1 | |
| 15 | Clapboard | 012051061706 | | 1 | |
| 16 | Rear Grill | 016001060101 | | 1 | |
| 17 | Valve Cover | 200087060009 | | 1 | |
| 18 | Handle | 200149060029 | | 1 | |
| 19 | Right Side Plate | 012056060565P | | 1 | |
| 20 | Cut off Valve Sub-Assy(1/4) | 030057060367 | | 4 | |
| 21 | Cut off Valve Sub-Assy(3/8) | 030057060366 | | 4 | |
| 22 | Valve Support Sub-Assy | 017104060062P | | 1 | |
| 23 | Electronic Expansion Valve assy | 030174060252 | | 1 | |
| 24 | 4-Way Valve Assy | 030152060946 | | 1 | |
| 25 | Compressor and Fittings | 009001060896 | | 1 | |
| 26 | Chassis Sub-assy | 017000060846P | | 1 | |
| 27 | Drainage hole Cap | 06813401 | | 4 | |
| 28 | Drainage Joint | 26113009 | | 1 | |
| 29 | Axial Flow Fan | 1043410000501 | | 1 | |
| 30 | Cabinet | 012022060021P | | 1 | |
| 31 | Front Grill | 200057060031 | | 1 | |
| | | | | | |

The data are subject to change without notice.

MV-E42BI2

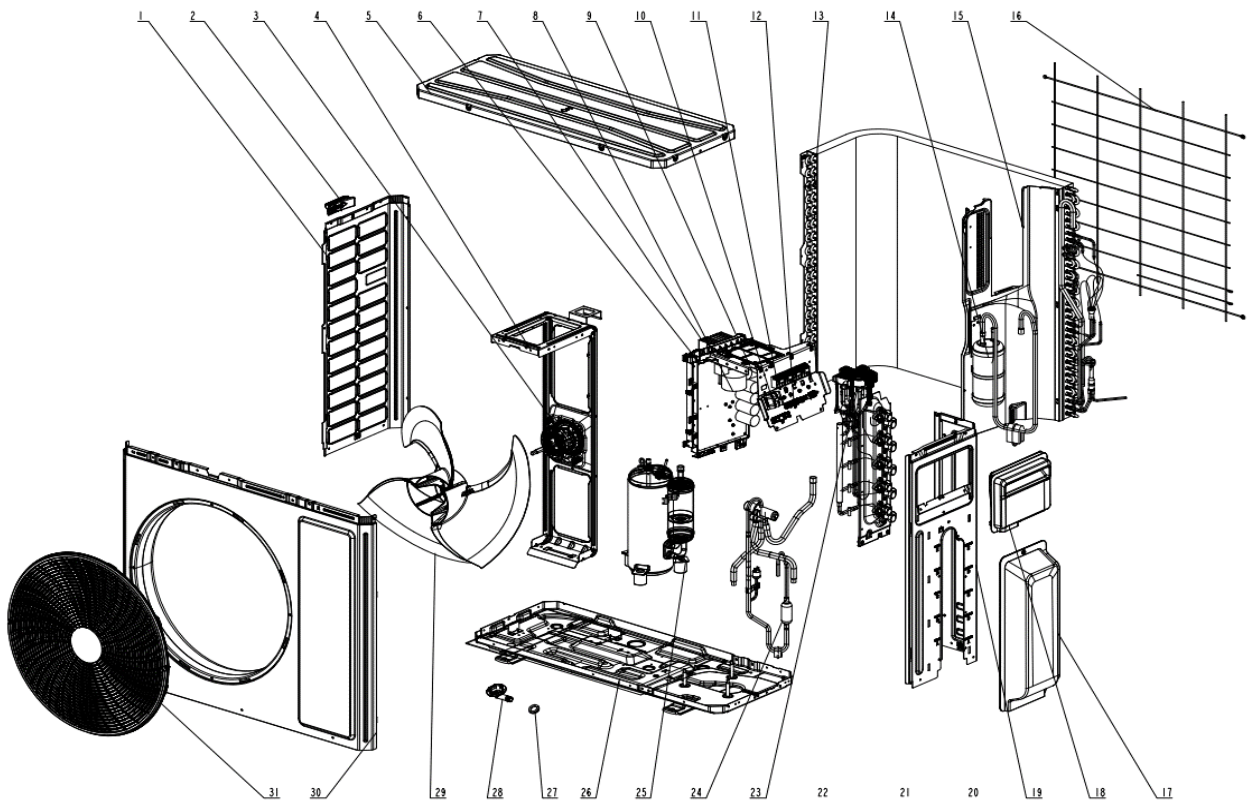

| No | Description | Part Code | Note | Qty | Price Code |
|-------------------------|---------------------------------|----------------|------|-----|------------|
| MODEL: MV-E42BI2 | | | | | |
| 1 | Left Side Plate | 012055060419P | | 1 | |
| 2 | Handle | 26233053 | | 1 | |
| 3 | Brushless DC Motor | 15010406011801 | | 1 | |
| 4 | Motor Support Sub-Assy | 017012060353 | | 1 | |
| 5 | Top cover | 012049060148P | | 1 | |
| 6 | Electric Box Assy | 100002075069 | | 1 | |
| 7 | Radiator | 430034060159 | | 1 | |
| 8 | Main Board | 300027062357 | | 1 | |
| 9 | Filter Board | 300020060099 | | 1 | |
| 10 | Terminal Board | 422000060012 | | 1 | |
| 11 | Terminal Board | 422000060015 | | 5 | |
| 12 | Wire Clamp | 200015060018 | | 2 | |
| 13 | Condenser Assy | 011002062063 | | 1 | |
| 14 | Gas-liquid Separator Assy | 07225017 | | 1 | |
| 15 | Clapboard | 012051061706 | | 1 | |
| 16 | Rear Grill | 016001060101 | | 1 | |
| 17 | Valve Cover | 200087060009 | | 1 | |
| 18 | Handle | 200149060029 | | 1 | |
| 19 | Right Side Plate | 012056060565P | | 1 | |
| 20 | Cut off Valve Sub-Assy(1/4) | 030057060367 | | 5 | |
| 21 | Cut off Valve Sub-Assy(3/8) | 030057060366 | | 5 | |
| 22 | Valve Support Sub-Assy | 017104060061P | | 1 | |
| 23 | Electronic Expansion Valve assy | 030174060240 | | 1 | |
| 24 | 4-Way Valve Assy | 030152060946 | | 1 | |
| 25 | Compressor and Fittings | 009001060896 | | 1 | |
| 26 | Chassis Sub-assy | 017000060846P | | 1 | |
| 27 | Drainage hole Cap | 06813401 | | 4 | |
| 28 | Drainage Joint | 26113009 | | 1 | |
| 29 | Axial Flow Fan | 1043410000501 | | 1 | |
| 30 | Cabinet | 012022060021P | | 1 | |
| 31 | Front Grill | 200057060031 | | 1 | |
| | | | | | |



The data are subject to change without notice.

11. Removal Procedure



MV-E14BI2
MV-E18BI2



Warning: Be sure to wait for a minimum of 20 minutes after turning off all power supplies and discharge the refrigerant completely before removal.

| Step | Procedure |
|------------------------------|--|
| 1. Before disassembly |  <p>Complete axonometric drawing.</p> |
| 2. Remove valve cover |  <p>Remove the connection screw fixing the valve cover and then remove the valve cover.</p> <p>valve cover</p> |
| 3. Remove handle |  <p>Remove the connection screws fixing the handle and the right side plate, and then remove the handle.</p> <p>Handle</p> |

11. Removal Procedure

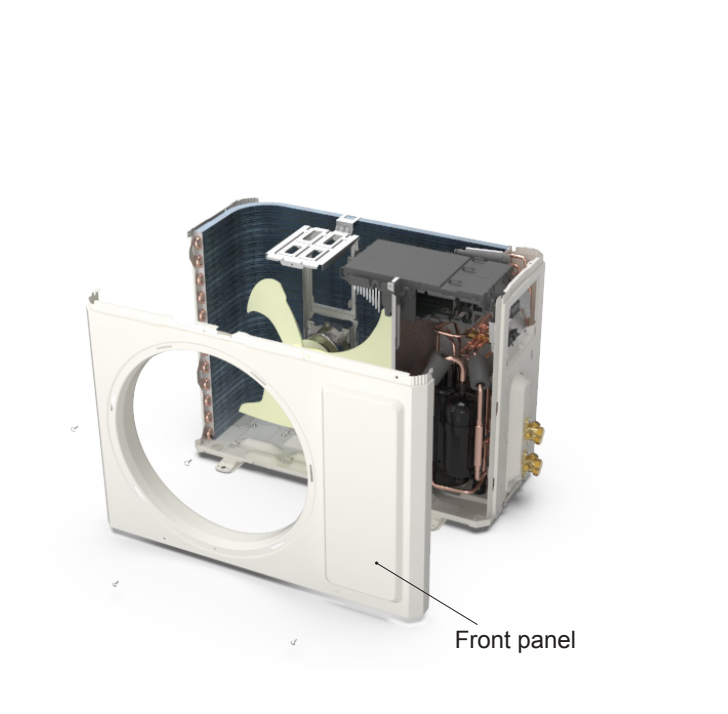
| Step | Procedure |
|-------------------------------|--|
| 4. Remove top panel | <p>Remove the connection screws connecting the top panel and the front panel, and then remove the top panel.</p>  |
| 5. Remove front grille | <p>Remove the connection screws connecting the front grille and the front panel, and then loosen the clasp to remove the front grille.</p>  |
| 6. Remove front panel | <p>Remove the screws connecting the front panel and then remove the front panel.</p>  |

11. Removal Procedure

| Step | Procedure |
|-----------------------------------|---|
| 7. Remove right side plate | <p>Remove the screws connecting the right side plate with the chassis and the valve support. Then remove the right side plate.</p>  <p>The diagram shows a 3D cutaway view of the unit's interior. A yellow fan is visible. On the right side, a metal plate is being detached from the chassis. An arrow points from the text 'Right side plate' to the plate.</p> |
| 8. Remove rear grill | <p>Remove the screws connecting the rear grill and left side plate, and then remove the rear grill.</p>  <p>The diagram shows a 3D cutaway view of the unit's interior. A yellow fan is visible. On the rear side, a metal grill is being detached from the left side plate. An arrow points from the text 'Rear grill' to the grill.</p> |
| 9. Remove left side plate | <p>Remove the screws fixing the left side plate with the chassis and the condenser support, and then remove the left side plate.</p>  <p>The diagram shows a 3D cutaway view of the unit's interior. A yellow fan is visible. On the left side, a metal plate is being detached from the chassis. An arrow points from the text 'Left side plate' to the plate.</p> |

11. Removal Procedure

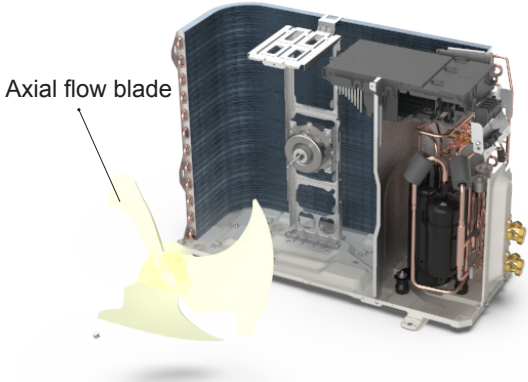
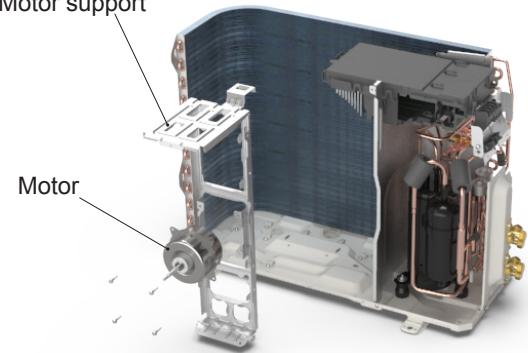
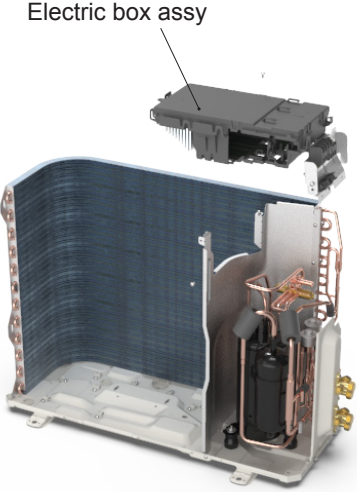
| Step | Procedure |
|---|---|
| 10. Remove axial flow blade | <p>Remove the nut on the blade and then remove the axial flow blade.</p>  |
| 11. Remove motor and motor support | <p>Remove the 4 tapping screws fixing the motor and disconnect the leading wire insert of the motor. Then remove the motor. Remove the 2 tapping screws fixing the motor support and chassis, and then lift the motor support to remove it.</p>  |
| 12. Remove electric box assy | <p>Remove the screws fixing the electric box assy and the middle isolation sheet, loosen the wire bundle, unplug the wiring terminals, and then lift the electric box assy to remove it.</p>  |

11. Removal Procedure

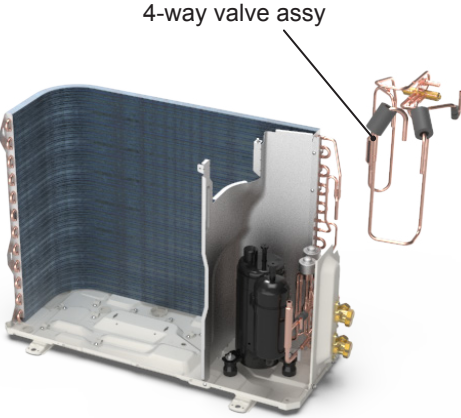
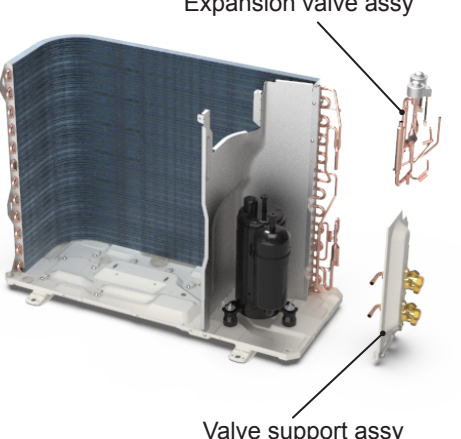
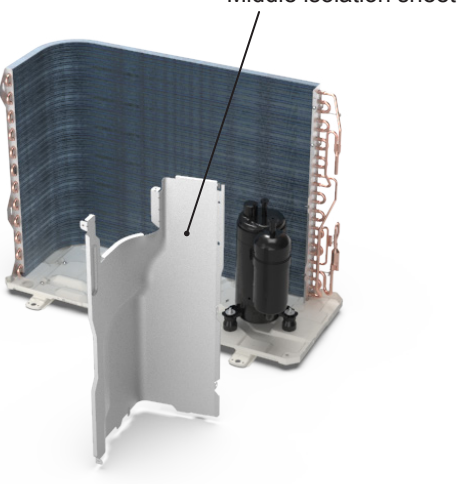
| Step | Procedure |
|---|---|
| 13. Remove 4-way valve assy | <p>Remove screws fixing the electricbox; loosen the wire bundle; pull out the wiring terminals and then pull electric box upwards to remove it.</p>  <p>4-way valve assy</p> |
| 14. Remove valve support sub-assy and expansion valve assy | <p>Remove the screw connecting the valve support and the chassis, and then remove the valve support assy. Unsolder the welding joint connecting the electronic expansion valve assy with the cut-off valve and the condenser connection pipe, and then remove the expansion valve assy.</p>  <p>Expansion valve assy</p> <p>Valve support assy</p> |
| 15. Remove middle isolation sheet | <p>Remove the screws connecting the middle isolation sheet with the chassis assy and the condenser assy, and then remove the middle isolation sheet.</p>  <p>Middle isolation sheet</p> |

11. Removal Procedure

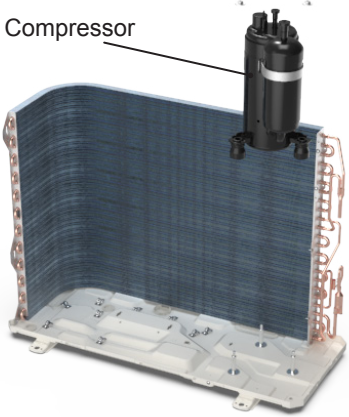
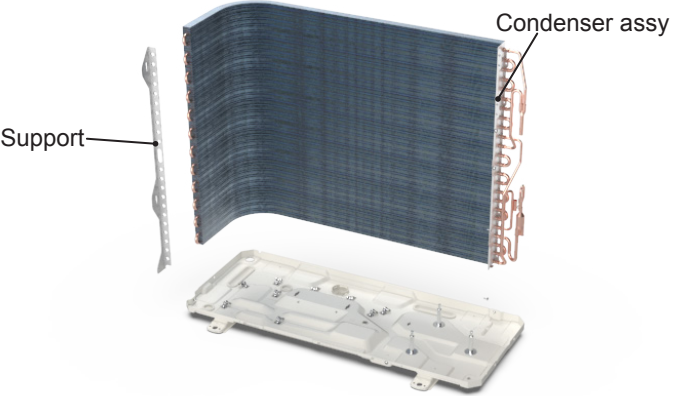

| Step | Procedure |
|----------------------------------|---|
| 16. Remove compressor |  <p>Remove the 3 foot nuts fixing the compressor and then remove the compressor.</p> |
| 17. Remove condenser assy |  <p>Remove the screws fixing the condenser support and then remove the condenser support. Remove the screws connecting the condenser support and the chassis assy, and then remove the condenser assy.</p> |

11. Removal Procedure

MV-E21BI2
MV-E24BI2



Warning: Be sure to wait for a minimum of 20 minutes after turning off all power supplies and discharge the refrigerant completely before removal.

| Step | Procedure |
|------------------------------|--|
| 1. Before disassembly |  <p>Complete axonometric drawing.</p> |
| 2. Remove valve cover |  <p>Remove the connection screw fixing the valve cover and then remove the valve cover.</p> <p>valve cover</p> |
| 3. Remove handle |  <p>Remove the connection screws fixing the handle and the right side plate, and then remove the handle.</p> <p>Handle</p> |

11. Removal Procedure

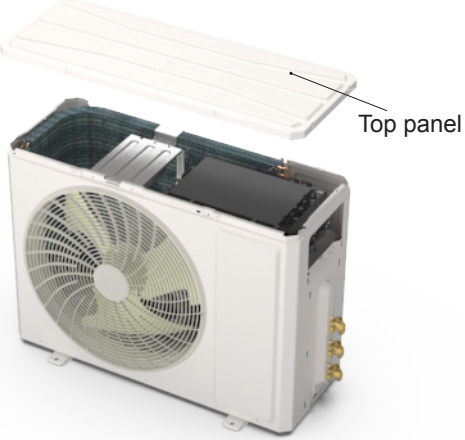
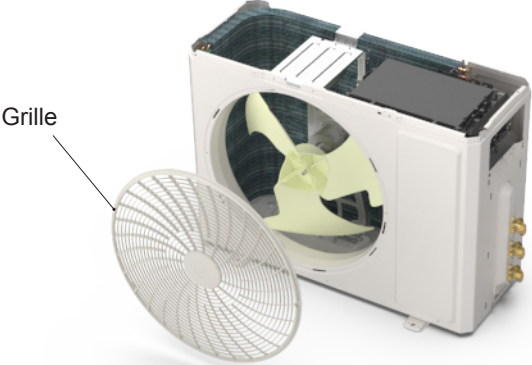
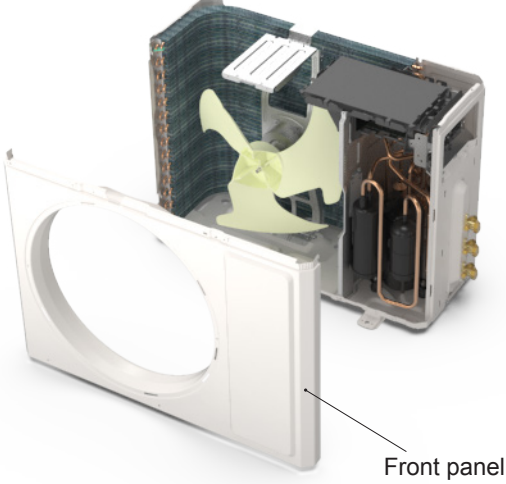
| Step | Procedure |
|-------------------------------|--|
| 4. Remove top panel | <p>Remove the connection screws connecting the top panel and the front panel, and then remove the top panel.</p>  |
| 5. Remove front grille | <p>Remove the connection screws connecting the front grille and the front panel, and then loosen the clasp to remove the front grille.</p>  |
| 6. Remove front panel | <p>Remove the screws connecting the front panel and then remove the front panel.</p>  |

11. Removal Procedure

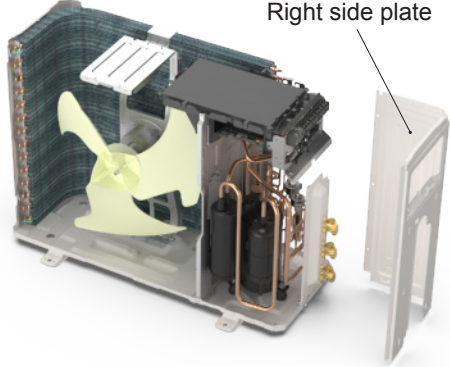
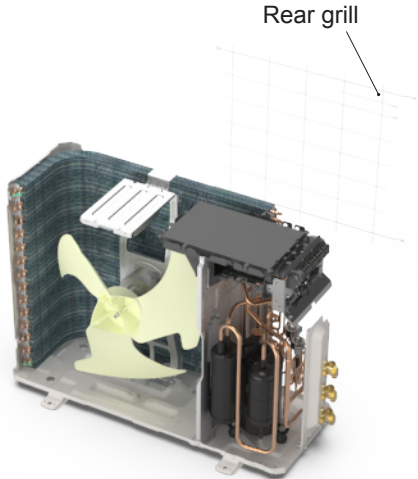
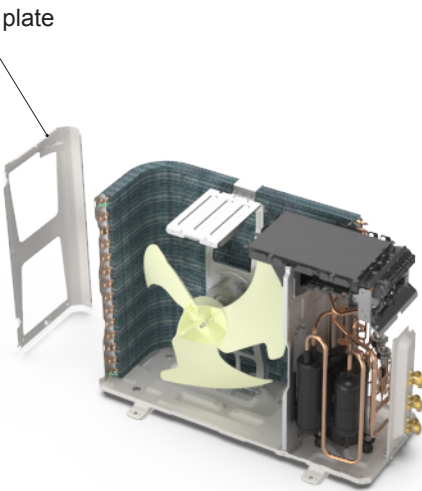
| Step | Procedure |
|-----------------------------------|--|
| 7. Remove right side plate | <p>Remove the screws connecting the right side plate with the chassis and the valve support. Then remove the right side plate.</p>  <p>Right side plate</p> |
| 8. Remove rear grill | <p>Remove the screws connecting the rear grill and left side plate, and then remove the rear grill.</p>  <p>Rear grill</p> |
| 9. Remove left side plate | <p>Remove the screws fixing the left side plate with the chassis and the condenser support, and then remove the left side plate.</p>  <p>Left side plate</p> |

11. Removal Procedure

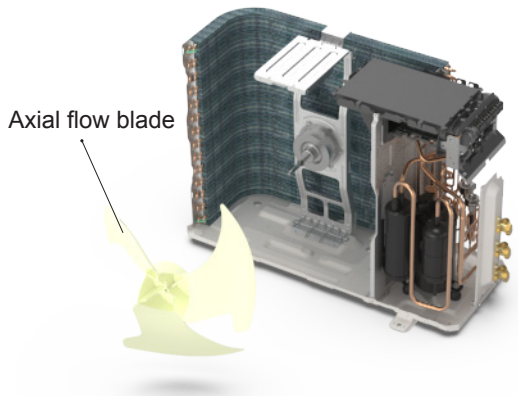
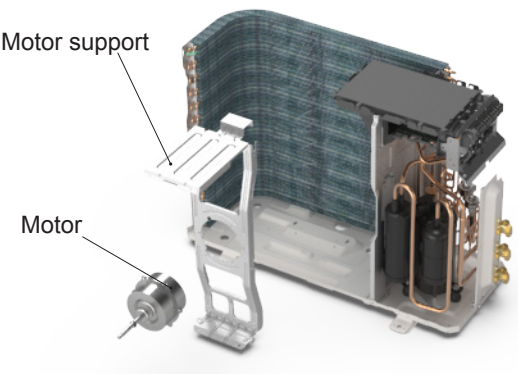
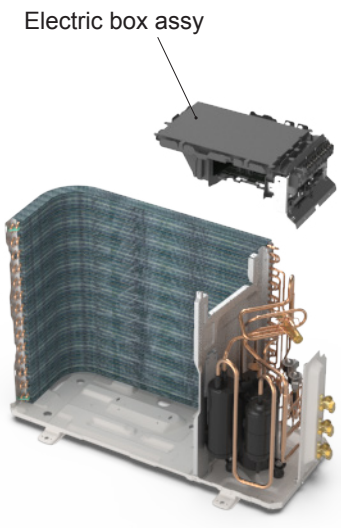
| Step | Procedure |
|---|---|
| 10. Remove axial flow blade | <p>Remove the nut on the blade and then remove the axial flow blade.</p>  <p>Axial flow blade</p> |
| 11. Remove motor and motor support | <p>Remove the 4 tapping screws fixing the motor and disconnect the leading wire insert of the motor. Then remove the motor. Remove the 2 tapping screws fixing the motor support and chassis, and then lift the motor support to remove it.</p>  <p>Motor support</p> <p>Motor</p> |
| 12. Remove electric box assy | <p>Remove the screws fixing the electric box assy and the middle isolation sheet, loosen the wire bundle, unplug the wiring terminals, and then lift the electric box assy to remove it.</p>  <p>Electric box assy</p> |

11. Removal Procedure

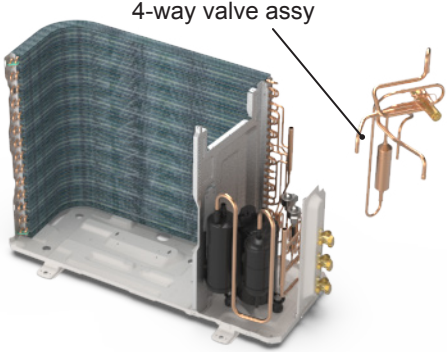
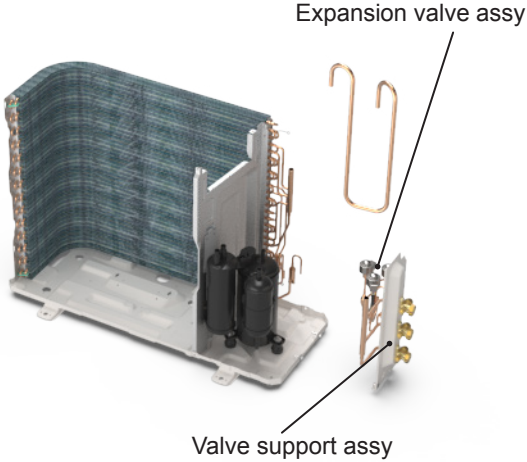
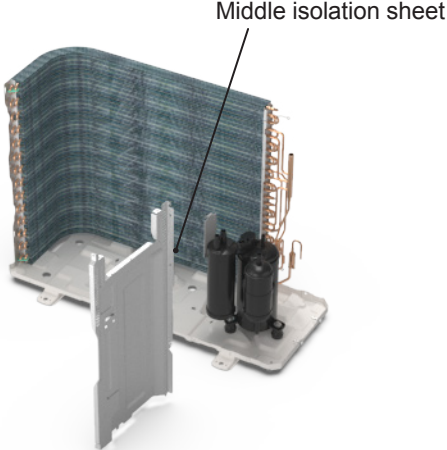
| Step | Procedure |
|---|---|
| 13. Remove 4-way valve assy | <p>Remove screws fixing the electricbox; loosen the wire bundle; pull out the wiring terminals and then pull electric box upwards to remove it.</p>  |
| 14. Remove valve support sub-assy and expansion valve assy | <p>Remove the screw connecting the valve support and the chassis, and then remove the valve support assy. Unsolder the welding joint connecting the electronic expansion valve assy with the cut-off valve and the condenser connection pipe, and then remove the expansion valve assy.</p>  |
| 15. Remove middle isolation sheet | <p>Remove the screws connecting the middle isolation sheet with the chassis assy and the condenser assy, and then remove the middle isolation sheet.</p>  |

11. Removal Procedure

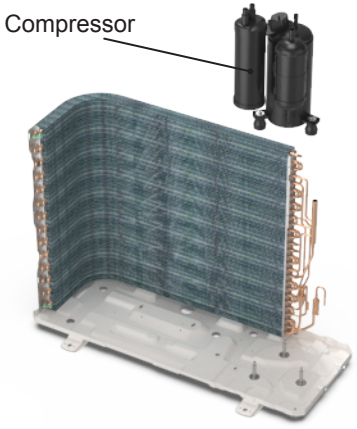
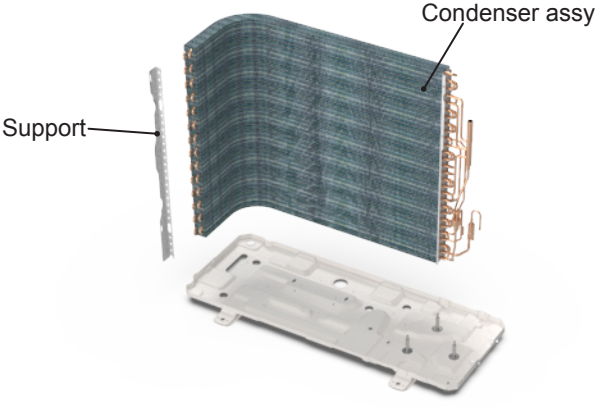

| Step | Procedure |
|----------------------------------|---|
| 16. Remove compressor | <p>Remove the 3 foot nuts fixing the compressor and then remove the compressor.</p>  |
| 17. Remove condenser assy | <p>Remove the screws fixing the condenser support and then remove the condenser support. Remove the screws connecting the condenser support and the chassis assy, and then remove the condenser assy.</p>  |

11. Removal Procedure



MV-E28BI2

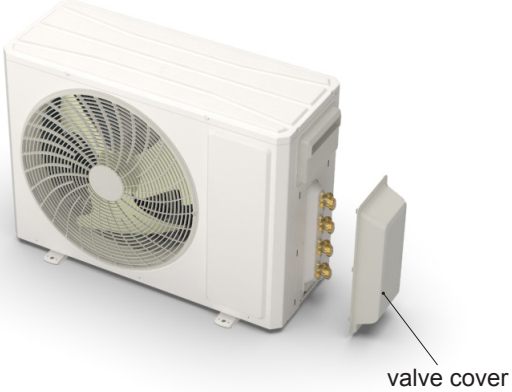

Warning: Be sure to wait for a minimum of 20 minutes after turning off all power supplies and discharge the refrigerant completely before removal.

| Step | Procedure |
|------------------------------|--|
| 1. Before disassembly |  <p>Complete axonometric drawing.</p> |
| 2. Remove valve cover |  <p>Remove the connection screw fixing the valve cover and then remove the valve cover.</p> |
| 3. Remove handle |  <p>Remove the connection screws fixing the handle and the right side plate, and then remove the handle.</p> |

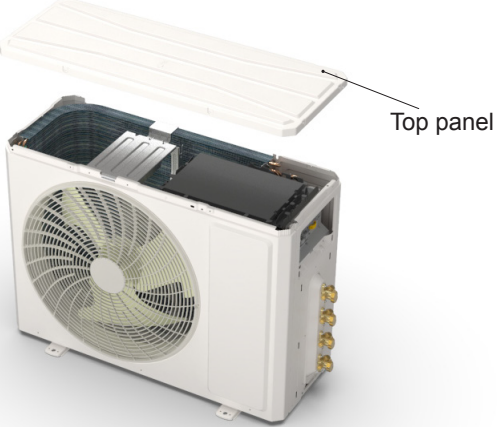
11. Removal Procedure

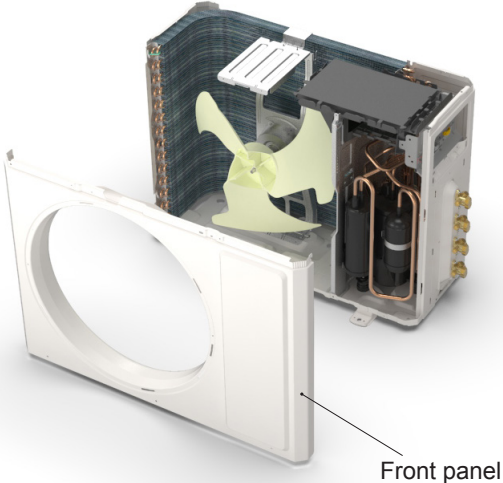
| Step | Procedure |
|-------------------------------|--|
| 4. Remove top panel | <p>Remove the connection screws connecting the top panel and the front panel, and then remove the top panel.</p>  |
| 5. Remove front grille | <p>Remove the connection screws connecting the front grille and the front panel, and then loosen the clasp to remove the front grille.</p>  |
| 6. Remove front panel | <p>Remove the screws connecting the front panel and then remove the front panel.</p>  |

11. Removal Procedure

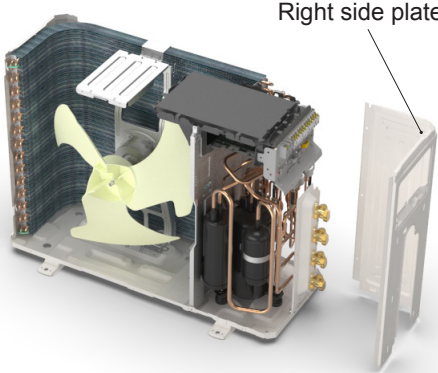
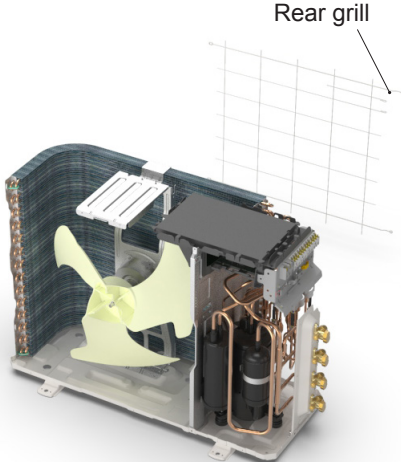
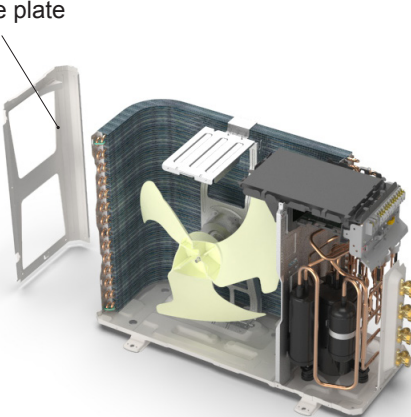
| Step | Procedure |
|-----------------------------------|---|
| 7. Remove right side plate | <p>Remove the screws connecting the right side plate with the chassis and the valve support. Then remove the right side plate.</p>  <p>The diagram shows a 3D cutaway view of the unit's internal components, including a yellow fan, a compressor, and copper piping. A grey metal plate, labeled 'Right side plate', is shown being lifted away from the right side of the chassis. An arrow points from the text label to the plate.</p> |
| 8. Remove rear grill | <p>Remove the screws connecting the rear grill and left side plate, and then remove the rear grill.</p>  <p>The diagram shows a 3D cutaway view of the unit's internal components. A white grid-like structure, labeled 'Rear grill', is shown being lifted away from the back of the chassis. An arrow points from the text label to the grill.</p> |
| 9. Remove left side plate | <p>Remove the screws fixing the left side plate with the chassis and the condenser support, and then remove the left side plate.</p>  <p>The diagram shows a 3D cutaway view of the unit's internal components. A grey metal plate, labeled 'Left side plate', is shown being lifted away from the left side of the chassis. An arrow points from the text label to the plate.</p> |

11. Removal Procedure

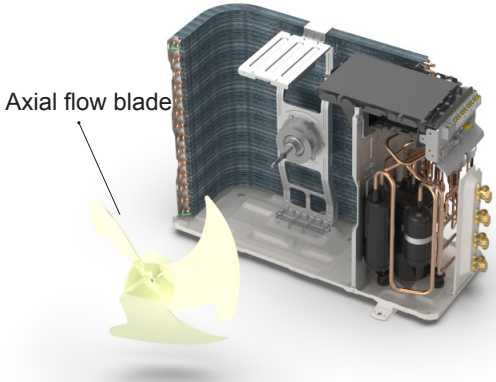
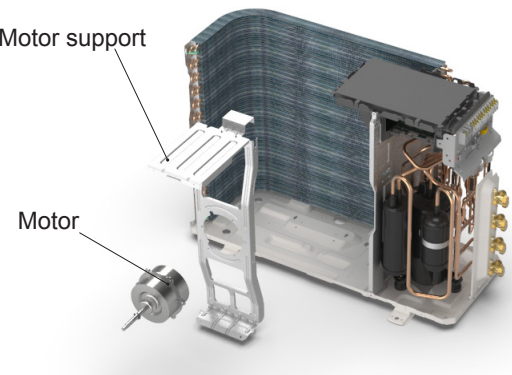
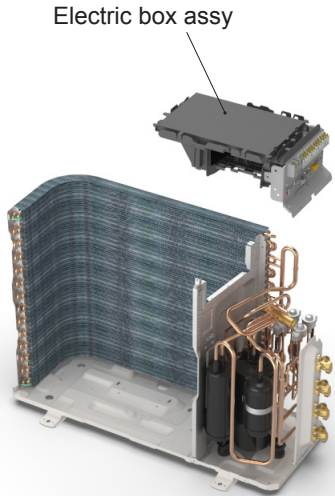
| Step | Procedure |
|---|---|
| 10. Remove axial flow blade |  <p>Axial flow blade</p> <p>Remove the nut on the blade and then remove the axial flow blade.</p> |
| 11. Remove motor and motor support |  <p>Motor support</p> <p>Motor</p> <p>Remove the 4 tapping screws fixing the motor and disconnect the leading wire insert of the motor. Then remove the motor. Remove the 2 tapping screws fixing the motor support and chassis, and then lift the motor support to remove it.</p> |
| 12. Remove electric box assy |  <p>Electric box assy</p> <p>Remove the screws fixing the electric box assy and the middle isolation sheet, loosen the wire bundle, unplug the wiring terminals, and then lift the electric box assy to remove it.</p> |

11. Removal Procedure

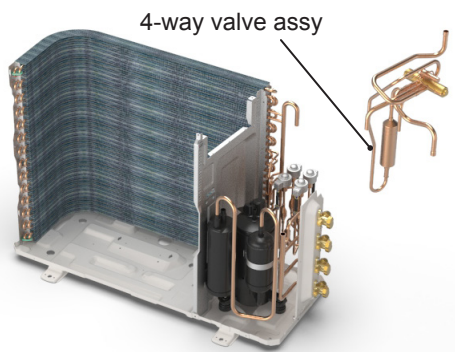
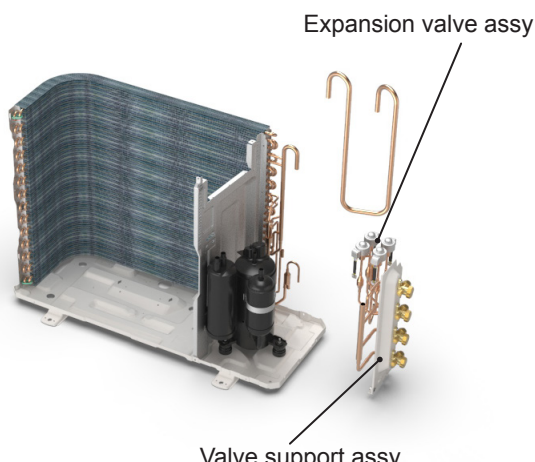
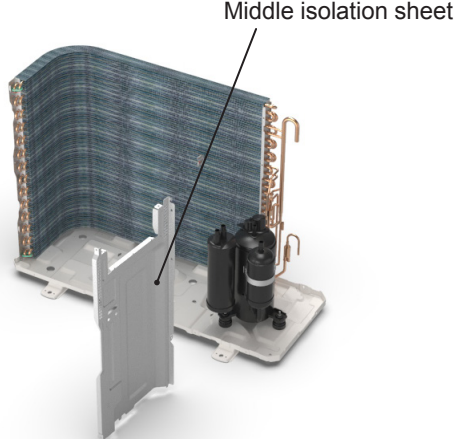
| Step | Procedure |
|---|---|
| 13. Remove 4-way valve assy | <p>Remove screws fixing the electricbox; loosen the wire bundle; pull out the wiring terminals and then pull electric box upwards to remove it.</p>  <p>4-way valve assy</p> |
| 14. Remove valve support sub-assy and expansion valve assy | <p>Remove the screw connecting the valve support and the chassis, and then remove the valve support assy. Unsolder the welding joint connecting the electronic expansion valve assy with the cut-off valve and the condenser connection pipe, and then remove the expansion valve assy.</p>  <p>Expansion valve assy</p> <p>Valve support assy</p> |
| 15. Remove middle isolation sheet | <p>Remove the screws connecting the middle isolation sheet with the chassis assy and the condenser assy, and then remove the middle isolation sheet.</p>  <p>Middle isolation sheet</p> |

11. Removal Procedure

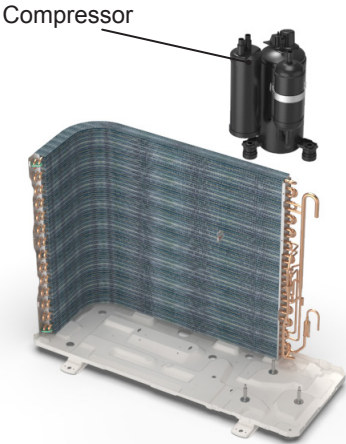
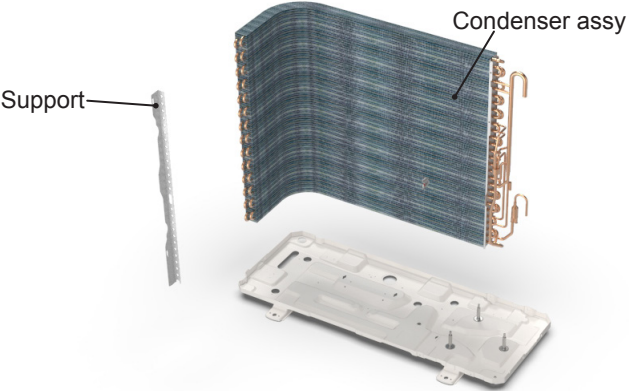
| Step | Procedure |
|----------------------------------|--|
| 16. Remove compressor | <p data-bbox="191 460 789 519">Remove the 3 foot nuts fixing the compressor and then remove the compressor.</p>  |
| 17. Remove condenser assy | <p data-bbox="191 974 789 1116">Remove the screws fixing the condenser support and then remove the condenser support. Remove the screws connecting the condenser support and the chassis assy, and then remove the condenser assy.</p>  |

11. Removal Procedure

MV-E36BI2
MV-E42BI2



NOTE: Take 42K model for example.

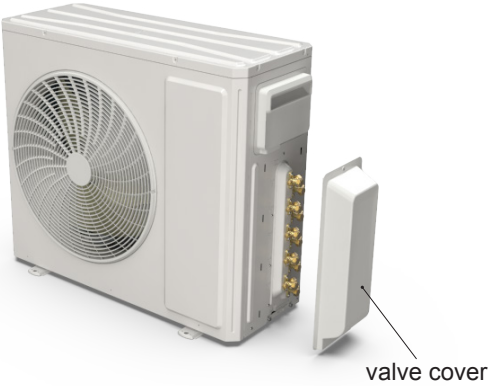
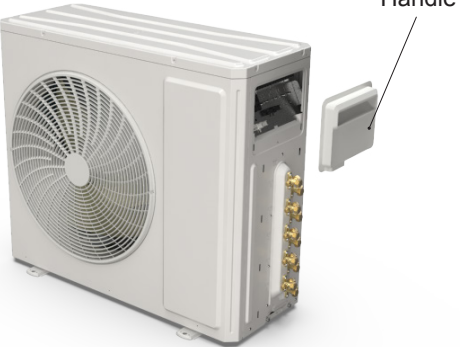

Warning: Be sure to wait for a minimum of 20 minutes after turning off all power supplies and discharge the refrigerant completely before removal.

| Step | Procedure |
|------------------------------|---|
| 1. Before disassembly | <p>Complete axonometric drawing.</p>  |
| 2. Remove valve cover | <p>Remove the connection screw fixing the valve cover and then remove the valve cover.</p>  |
| 3. Remove handle | <p>Remove the connection screws fixing the handle and the right side plate, and then remove the handle.</p>  |

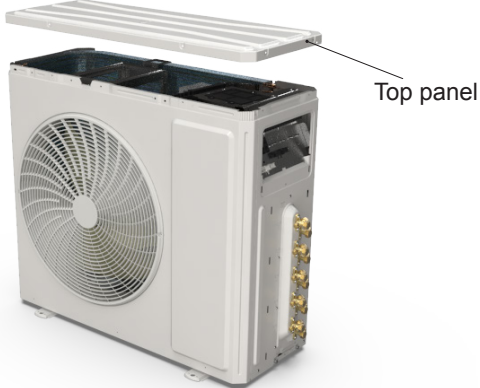
11. Removal Procedure

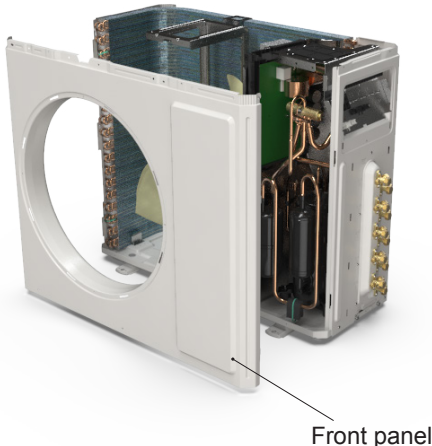
| Step | Procedure |
|-------------------------------|--|
| 4. Remove top panel | <p>Remove the connection screws connecting the top panel and the front panel, and then remove the top panel.</p>  |
| 5. Remove front grille | <p>Remove the connection screws connecting the front grille and the front panel, and then loosen the clasp to remove the front grille.</p>  |
| 6. Remove front panel | <p>Remove the screws connecting the front panel and then remove the front panel.</p>  |

11. Removal Procedure

| Step | Procedure |
|-----------------------------------|---|
| 7. Remove right side plate | <p>Remove the screws connecting the right side plate with the chassis and the valve support. Then remove the right side plate.</p>  |
| 8. Remove rear grill | <p>Remove the screws connecting the rear grill and left side plate, and then remove the rear grill.</p>  |
| 9. Remove left side plate | <p>Remove the screws fixing the left side plate with the chassis and the condenser support, and then remove the left side plate.</p>  |

11. Removal Procedure

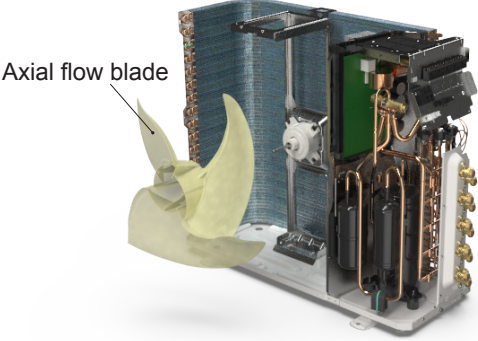
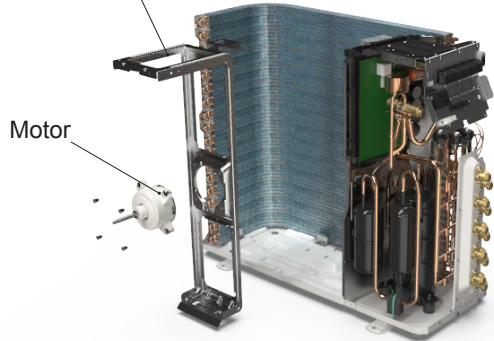
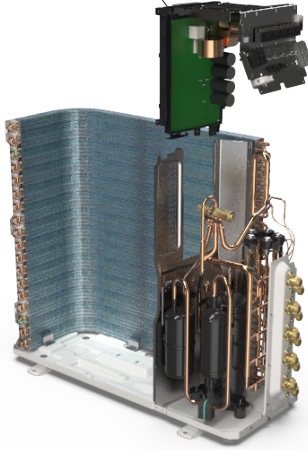
| Step | Procedure |
|---|---|
| 10. Remove axial flow blade | <p>Remove the nut on the blade and then remove the axial flow blade.</p>  <p>Axial flow blade</p> |
| 11. Remove motor and motor support | <p>Remove the 4 tapping screws fixing the motor and disconnect the leading wire insert of the motor. Then remove the motor. Remove the 2 tapping screws fixing the motor support and chassis, and then lift the motor support to remove it.</p>  <p>Motor support</p> <p>Motor</p> |
| 12. Remove electric box assy | <p>Remove the screws fixing the electric box assy and the middle isolation sheet, loosen the wire bundle, unplug the wiring terminals, and then lift the electric box assy to remove it.</p>  <p>Electric box assy</p> |

11. Removal Procedure

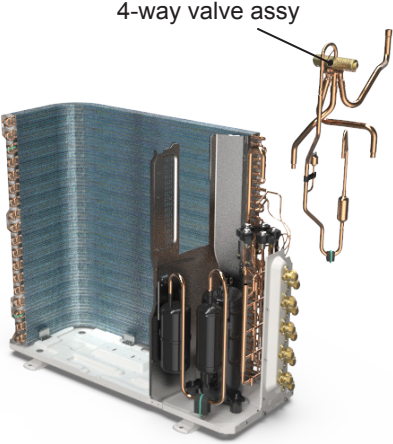
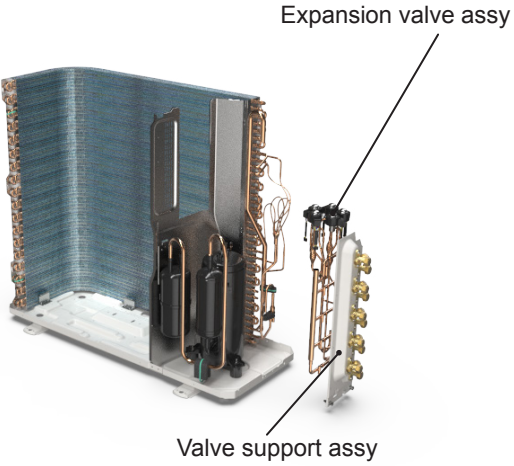
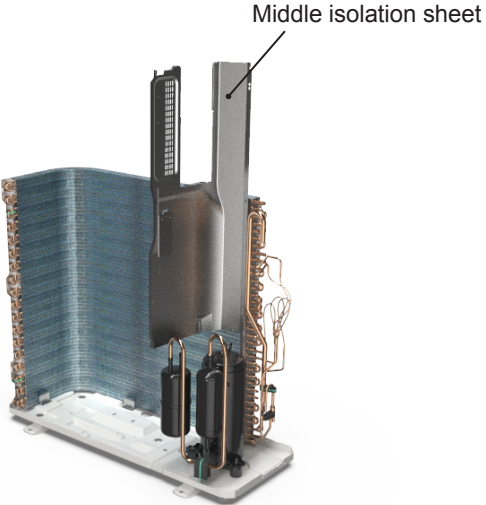
| Step | Procedure |
|---|--|
| 13. Remove 4-way valve assy | <p>Remove screws fixing the electricbox; loosen the wire bundle; pull out the wiring terminals and then pull electric box upwards to remove it.</p>  <p>4-way valve assy</p> |
| 14. Remove valve support sub-assy and expansion valve assy | <p>Remove the screw connecting the valve support and the chassis, and then remove the valve support assy. Unsolder the welding joint connecting the electronic expansion valve assy with the cut-off valve and the condenser connection pipe, and then remove the expansion valve assy.</p>  <p>Expansion valve assy</p> <p>Valve support assy</p> |
| 15. Remove middle isolation sheet | <p>Remove the screws connecting the middle isolation sheet with the chassis assy and the condenser assy, and then remove the middle isolation sheet.</p>  <p>Middle isolation sheet</p> |

11. Removal Procedure

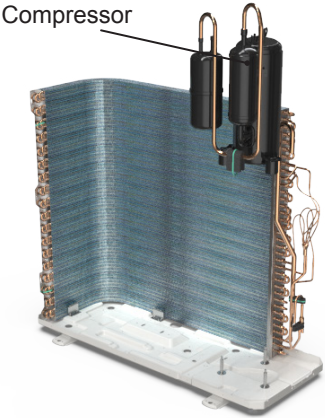
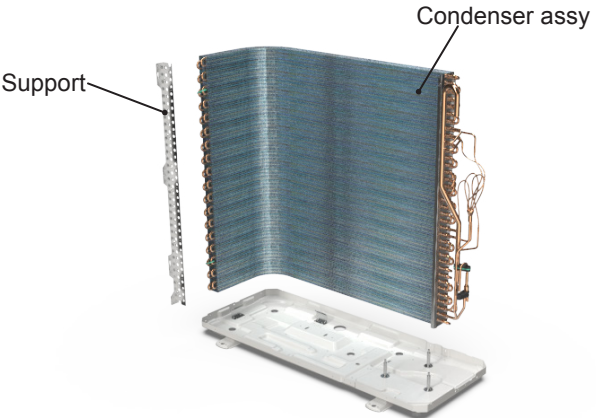
| Step | Procedure |
|----------------------------------|---|
| 16. Remove compressor |  <p>Remove the 3 foot nuts fixing the compressor and then remove the compressor.</p> |
| 17. Remove condenser assy |  <p>Remove the screws fixing the condenser support and then remove the condenser support. Remove the screws connecting the condenser support and the chassis assy, and then remove the condenser assy.</p> |

Appendix

Appendix 1: Reference Sheet of Celsius and Fahrenheit

Conversion formula for Fahrenheit degree and Celsius degree: $T_f = T_c \times 1.8 + 32$

Set temperature

| Fahrenheit display temperature (°F) | Fahrenheit (°F) | Celsius (°C) | Fahrenheit display temperature (°F) | Fahrenheit (°F) | Celsius (°C) | Fahrenheit display temperature (°F) | Fahrenheit (°F) | Celsius (°C) |
|-------------------------------------|-----------------|--------------|-------------------------------------|-----------------|--------------|-------------------------------------|-----------------|--------------|
| 61 | 60.8 | 16 | 69/70 | 69.8 | 21 | 78/79 | 78.8 | 26 |
| 62/63 | 62.6 | 17 | 71/72 | 71.6 | 22 | 80/81 | 80.6 | 27 |
| 64/65 | 64.4 | 18 | 73/74 | 73.4 | 23 | 82/83 | 82.4 | 28 |
| 66/67 | 66.2 | 19 | 75/76 | 75.2 | 24 | 84/85 | 84.2 | 29 |
| 68 | 68 | 20 | 77 | 77 | 25 | 86 | 86 | 30 |

Ambient temperature

| Fahrenheit display temperature (°F) | Fahrenheit (°F) | Celsius (°C) | Fahrenheit display temperature (°F) | Fahrenheit (°F) | Celsius (°C) | Fahrenheit display temperature (°F) | Fahrenheit (°F) | Celsius (°C) |
|-------------------------------------|-----------------|--------------|-------------------------------------|-----------------|--------------|-------------------------------------|-----------------|--------------|
| 32/33 | 32 | 0 | 55/56 | 55.4 | 13 | 79/80 | 78.8 | 26 |
| 34/35 | 33.8 | 1 | 57/58 | 57.2 | 14 | 81 | 80.6 | 27 |
| 36 | 35.6 | 2 | 59/60 | 59 | 15 | 82/83 | 82.4 | 28 |
| 37/38 | 37.4 | 3 | 61/62 | 60.8 | 16 | 84/85 | 84.2 | 29 |
| 39/40 | 39.2 | 4 | 63 | 62.6 | 17 | 86/87 | 86 | 30 |
| 41/42 | 41 | 5 | 64/65 | 64.4 | 18 | 88/89 | 87.8 | 31 |
| 43/44 | 42.8 | 6 | 66/67 | 66.2 | 19 | 90 | 89.6 | 32 |
| 45 | 44.6 | 7 | 68/69 | 68 | 20 | 91/92 | 91.4 | 33 |
| 46/47 | 46.4 | 8 | 70/71 | 69.8 | 21 | 93/94 | 93.2 | 34 |
| 48/49 | 48.2 | 9 | 72 | 71.6 | 22 | 95/96 | 95 | 35 |
| 50/51 | 50 | 10 | 73/74 | 73.4 | 23 | 97/98 | 96.8 | 36 |
| 52/53 | 51.8 | 11 | 75/76 | 75.2 | 24 | 99 | 98.6 | 37 |
| 54 | 53.6 | 12 | 77/78 | 77 | 25 | | | |

Appendix

Appendix 2: Pipe Expanding Method

⚠ Note:

Improper pipe expanding is the main cause of refrigerant leakage. Please expand the pipe according to the following steps:

A: Cut the pipe

- Confirm the pipe length according to the distance of indoor unit and outdoor unit.
- Cut the required pipe with pipe cutter.

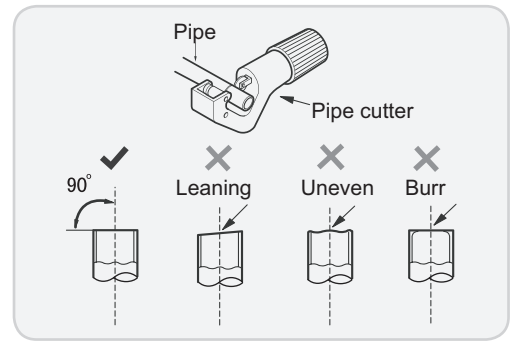

B: Remove the burrs

- Remove the burrs with shaper and prevent the burrs from getting into the pipe.

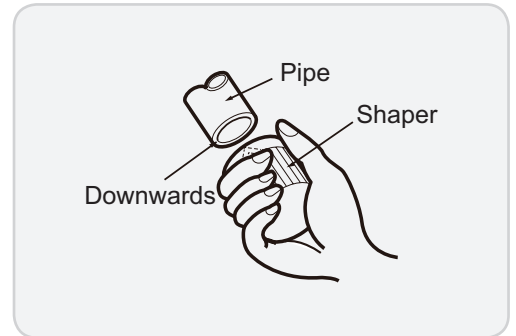

C: Put on suitable insulating pipe.

D: Put on the union nut

- Remove the union nut on the indoor connection pipe and outdoor valve; install the union nut on the pipe.

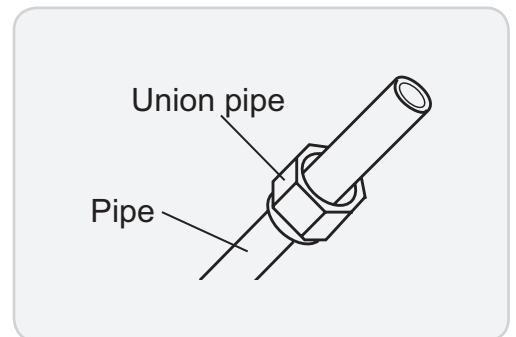

E: Expand the port

- Expand the port with expander.

⚠ Note:

- "A" is different according to the diameter, please refer to the sheet below:

| Outer diameter(mm) | A(mm) | |
|--------------------|-------|-----|
| | Max | Min |
| Φ6 - 6.35 (1/4") | 1.3 | 0.7 |
| Φ9 - Φ9.52 (3/8") | 1.6 | 1.0 |
| Φ12 - 12.70 (1/2") | 1.8 | 1.0 |
| Φ16 - 15.88 (5/8") | 2.4 | 2.2 |

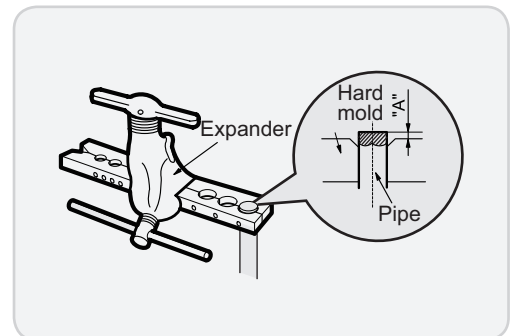

F: Inspection

- Check the quality of expanding port. If there is any blemish, expand the port again according to the steps above.

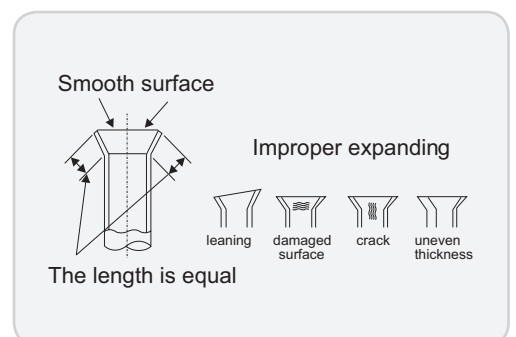

Appendix

Appendix 3: List of Resistance for Temperature Sensor

Resistance Table of Ambient Temperature Sensor for Indoor and Outdoor Units(15K)

| Temp(°C) | Resistance(kΩ) | Temp(°C) | Resistance(kΩ) | Temp(°C) | Resistance(kΩ) | Temp(°C) | Resistance(kΩ) |
|----------|----------------|----------|----------------|----------|----------------|----------|----------------|
| -19 | 138.1 | 20 | 18.75 | 59 | 3.848 | 98 | 1.071 |
| -18 | 128.6 | 21 | 17.93 | 60 | 3.711 | 99 | 1.039 |
| -17 | 121.6 | 22 | 17.14 | 61 | 3.579 | 100 | 1.009 |
| -16 | 115 | 23 | 16.39 | 62 | 3.454 | 101 | 0.98 |
| -15 | 108.7 | 24 | 15.68 | 63 | 3.333 | 102 | 0.952 |
| -14 | 102.9 | 25 | 15 | 64 | 3.217 | 103 | 0.925 |
| -13 | 97.4 | 26 | 14.36 | 65 | 3.105 | 104 | 0.898 |
| -12 | 92.22 | 27 | 13.74 | 66 | 2.998 | 105 | 0.873 |
| -11 | 87.35 | 28 | 13.16 | 67 | 2.896 | 106 | 0.848 |
| -10 | 82.75 | 29 | 12.6 | 68 | 2.797 | 107 | 0.825 |
| -9 | 78.43 | 30 | 12.07 | 69 | 2.702 | 108 | 0.802 |
| -8 | 74.35 | 31 | 11.57 | 70 | 2.611 | 109 | 0.779 |
| -7 | 70.5 | 32 | 11.09 | 71 | 2.523 | 110 | 0.758 |
| -6 | 66.88 | 33 | 10.63 | 72 | 2.439 | 111 | 0.737 |
| -5 | 63.46 | 34 | 10.2 | 73 | 2.358 | 112 | 0.717 |
| -4 | 60.23 | 35 | 9.779 | 74 | 2.28 | 113 | 0.697 |
| -3 | 57.18 | 36 | 9.382 | 75 | 2.206 | 114 | 0.678 |
| -2 | 54.31 | 37 | 9.003 | 76 | 2.133 | 115 | 0.66 |
| -1 | 51.59 | 38 | 8.642 | 77 | 2.064 | 116 | 0.642 |
| 0 | 49.02 | 39 | 8.297 | 78 | 1.997 | 117 | 0.625 |
| 1 | 46.6 | 40 | 7.967 | 79 | 1.933 | 118 | 0.608 |
| 2 | 44.31 | 41 | 7.653 | 80 | 1.871 | 119 | 0.592 |
| 3 | 42.14 | 42 | 7.352 | 81 | 1.811 | 120 | 0.577 |
| 4 | 40.09 | 43 | 7.065 | 82 | 1.754 | 121 | 0.561 |
| 5 | 38.15 | 44 | 6.791 | 83 | 1.699 | 122 | 0.547 |
| 6 | 36.32 | 45 | 6.529 | 84 | 1.645 | 123 | 0.532 |
| 7 | 34.58 | 46 | 6.278 | 85 | 1.594 | 124 | 0.519 |
| 8 | 32.94 | 47 | 6.038 | 86 | 1.544 | 125 | 0.505 |
| 9 | 31.38 | 48 | 5.809 | 87 | 1.497 | 126 | 0.492 |
| 10 | 29.9 | 49 | 5.589 | 88 | 1.451 | 127 | 0.48 |
| 11 | 28.51 | 50 | 5.379 | 89 | 1.408 | 128 | 0.467 |
| 12 | 27.18 | 51 | 5.197 | 90 | 1.363 | 129 | 0.456 |
| 13 | 25.92 | 52 | 4.986 | 91 | 1.322 | 130 | 0.444 |
| 14 | 24.73 | 53 | 4.802 | 92 | 1.282 | 131 | 0.433 |
| 15 | 23.6 | 54 | 4.625 | 93 | 1.244 | 132 | 0.422 |
| 16 | 22.53 | 55 | 4.456 | 94 | 1.207 | 133 | 0.412 |
| 17 | 21.51 | 56 | 4.294 | 95 | 1.171 | 134 | 0.401 |
| 18 | 20.54 | 57 | 4.139 | 96 | 1.136 | 135 | 0.391 |
| 19 | 19.63 | 58 | 3.99 | 97 | 1.103 | 136 | 0.382 |

Appendix

Resistance Table of Tube Temperature Sensors for Indoor and Outdoor (20K)

| Temp(°C) | Resistance(kΩ) | Temp(°C) | Resistance(kΩ) | Temp(°C) | Resistance(kΩ) | Temp(°C) | Resistance(kΩ) |
|----------|----------------|----------|----------------|----------|----------------|----------|----------------|
| -19 | 181.4 | 20 | 25.01 | 59 | 5.13 | 98 | 1.427 |
| -18 | 171.4 | 21 | 23.9 | 60 | 4.948 | 99 | 1.386 |
| -17 | 162.1 | 22 | 22.85 | 61 | 4.773 | 100 | 1.346 |
| -16 | 153.3 | 23 | 21.85 | 62 | 4.605 | 101 | 1.307 |
| -15 | 145 | 24 | 20.9 | 63 | 4.443 | 102 | 1.269 |
| -14 | 137.2 | 25 | 20 | 64 | 4.289 | 103 | 1.233 |
| -13 | 129.9 | 26 | 19.14 | 65 | 4.14 | 104 | 1.198 |
| -12 | 123 | 27 | 18.13 | 66 | 3.998 | 105 | 1.164 |
| -11 | 116.5 | 28 | 17.55 | 67 | 3.861 | 106 | 1.131 |
| -10 | 110.3 | 29 | 16.8 | 68 | 3.729 | 107 | 1.099 |
| -9 | 104.6 | 30 | 16.1 | 69 | 3.603 | 108 | 1.069 |
| -8 | 99.13 | 31 | 15.43 | 70 | 3.481 | 109 | 1.039 |
| -7 | 94 | 32 | 14.79 | 71 | 3.364 | 110 | 1.01 |
| -6 | 89.17 | 33 | 14.18 | 72 | 3.252 | 111 | 0.983 |
| -5 | 84.61 | 34 | 13.59 | 73 | 3.144 | 112 | 0.956 |
| -4 | 80.31 | 35 | 13.04 | 74 | 3.04 | 113 | 0.93 |
| -3 | 76.24 | 36 | 12.51 | 75 | 2.94 | 114 | 0.904 |
| -2 | 72.41 | 37 | 12 | 76 | 2.844 | 115 | 0.88 |
| -1 | 68.79 | 38 | 11.52 | 77 | 2.752 | 116 | 0.856 |
| 0 | 65.37 | 39 | 11.06 | 78 | 2.663 | 117 | 0.833 |
| 1 | 62.13 | 40 | 10.62 | 79 | 2.577 | 118 | 0.811 |
| 2 | 59.08 | 41 | 10.2 | 80 | 2.495 | 119 | 0.77 |
| 3 | 56.19 | 42 | 9.803 | 81 | 2.415 | 120 | 0.769 |
| 4 | 53.46 | 43 | 9.42 | 82 | 2.339 | 121 | 0.746 |
| 5 | 50.87 | 44 | 9.054 | 83 | 2.265 | 122 | 0.729 |
| 6 | 48.42 | 45 | 8.705 | 84 | 2.194 | 123 | 0.71 |
| 7 | 46.11 | 46 | 8.37 | 85 | 2.125 | 124 | 0.692 |
| 8 | 43.92 | 47 | 8.051 | 86 | 2.059 | 125 | 0.674 |
| 9 | 41.84 | 48 | 7.745 | 87 | 1.996 | 126 | 0.658 |
| 10 | 39.87 | 49 | 7.453 | 88 | 1.934 | 127 | 0.64 |
| 11 | 38.01 | 50 | 7.173 | 89 | 1.875 | 128 | 0.623 |
| 12 | 36.24 | 51 | 6.905 | 90 | 1.818 | 129 | 0.607 |
| 13 | 34.57 | 52 | 6.648 | 91 | 1.736 | 130 | 0.592 |
| 14 | 32.98 | 53 | 6.403 | 92 | 1.71 | 131 | 0.577 |
| 15 | 31.47 | 54 | 6.167 | 93 | 1.658 | 132 | 0.563 |
| 16 | 30.04 | 55 | 5.942 | 94 | 1.609 | 133 | 0.549 |
| 17 | 28.68 | 56 | 5.726 | 95 | 1.561 | 134 | 0.535 |
| 18 | 27.39 | 57 | 5.519 | 96 | 1.515 | 135 | 0.521 |
| 19 | 26.17 | 58 | 5.32 | 97 | 1.47 | 136 | 0.509 |

Appendix

Resistance Table of Discharge Temperature Sensor for Outdoor(50K)

| Temp(°C) | Resistance(kΩ) | Temp(°C) | Resistance(kΩ) | Temp(°C) | Resistance(kΩ) | Temp(°C) | Resistance(kΩ) |
|----------|----------------|----------|----------------|----------|----------------|----------|----------------|
| -29 | 853.5 | 10 | 98 | 49 | 18.34 | 88 | 4.75 |
| -28 | 799.8 | 11 | 93.42 | 50 | 17.65 | 89 | 4.61 |
| -27 | 750 | 12 | 89.07 | 51 | 16.99 | 90 | 4.47 |
| -26 | 703.8 | 13 | 84.95 | 52 | 16.36 | 91 | 4.33 |
| -25 | 660.8 | 14 | 81.05 | 53 | 15.75 | 92 | 4.20 |
| -24 | 620.8 | 15 | 77.35 | 54 | 15.17 | 93 | 4.08 |
| -23 | 580.6 | 16 | 73.83 | 55 | 14.62 | 94 | 3.96 |
| -22 | 548.9 | 17 | 70.5 | 56 | 14.09 | 95 | 3.84 |
| -21 | 516.6 | 18 | 67.34 | 57 | 13.58 | 96 | 3.73 |
| -20 | 486.5 | 19 | 64.33 | 58 | 13.09 | 97 | 3.62 |
| -19 | 458.3 | 20 | 61.48 | 59 | 12.62 | 98 | 3.51 |
| -18 | 432 | 21 | 58.77 | 60 | 12.17 | 99 | 3.41 |
| -17 | 407.4 | 22 | 56.19 | 61 | 11.74 | 100 | 3.32 |
| -16 | 384.5 | 23 | 53.74 | 62 | 11.32 | 101 | 3.22 |
| -15 | 362.9 | 24 | 51.41 | 63 | 10.93 | 102 | 3.13 |
| -14 | 342.8 | 25 | 49.19 | 64 | 10.54 | 103 | 3.04 |
| -13 | 323.9 | 26 | 47.08 | 65 | 10.18 | 104 | 2.96 |
| -12 | 306.2 | 27 | 45.07 | 66 | 9.83 | 105 | 2.87 |
| -11 | 289.6 | 28 | 43.16 | 67 | 9.49 | 106 | 2.79 |
| -10 | 274 | 29 | 41.34 | 68 | 9.17 | 107 | 2.72 |
| -9 | 259.3 | 30 | 39.61 | 69 | 8.85 | 108 | 2.64 |
| -8 | 245.6 | 31 | 37.96 | 70 | 8.56 | 109 | 2.57 |
| -7 | 232.6 | 32 | 36.38 | 71 | 8.27 | 110 | 2.50 |
| -6 | 220.5 | 33 | 34.88 | 72 | 7.99 | 111 | 2.43 |
| -5 | 209 | 34 | 33.45 | 73 | 7.73 | 112 | 2.37 |
| -4 | 198.3 | 35 | 32.09 | 74 | 7.47 | 113 | 2.30 |
| -3 | 199.1 | 36 | 30.79 | 75 | 7.22 | 114 | 2.24 |
| -2 | 178.5 | 37 | 29.54 | 76 | 7.00 | 115 | 2.18 |
| -1 | 169.5 | 38 | 28.36 | 77 | 6.76 | 116 | 2.12 |
| 0 | 161 | 39 | 27.23 | 78 | 6.54 | 117 | 2.07 |
| 1 | 153 | 40 | 26.15 | 79 | 6.33 | 118 | 2.02 |
| 2 | 145.4 | 41 | 25.11 | 80 | 6.13 | 119 | 1.96 |
| 3 | 138.3 | 42 | 24.13 | 81 | 5.93 | 120 | 1.91 |
| 4 | 131.5 | 43 | 23.19 | 82 | 5.75 | 121 | 1.86 |
| 5 | 125.1 | 44 | 22.29 | 83 | 5.57 | 122 | 1.82 |
| 6 | 119.1 | 45 | 21.43 | 84 | 5.39 | 123 | 1.77 |
| 7 | 113.4 | 46 | 20.6 | 85 | 5.22 | 124 | 1.73 |
| 8 | 108 | 47 | 19.81 | 86 | 5.06 | 125 | 1.68 |
| 9 | 102.8 | 48 | 19.06 | 87 | 4.90 | 126 | 1.64 |

NOTE CONCERNING PROTECTION OF ENVIRONMENT



This product must not be disposed of via normal household waste after its service life, but must be taken to a collection station for the recycling of electrical and electronic devices. The symbol on the product, the operating instructions or the packaging indicate such disposal procedures. The materials are recyclable in accordance with their respective symbols. By means of re-use, material recycling or any other form of recycling old appliances you are making an important contribution to the protection of our environment. Please ask your local council where your nearest disposal station is located.

INFORMATION CONCERNING USED REFRIGERANT MEDIUM

This unit is containing fluorinated gases included in the Kyoto protocol.
The maintenance and the liquidation must be carried out by qualified personnel.

Type of refrigerant: R32

The quantity of the refrigerant: Please see the unit label.

The value GWP: 675 (1 kg R32 = 0,675 t CO₂ eq)

GWP = Global Warming Potential



Appliance filled with flammable gas R32.

In case of quality problem or other please contact your local supplier or authorized service center.

Emergency number: 112

PRODUCER

SINCLAIR CORPORATION Ltd.

1-4 Argyll St.

London W1F 7LD

Great Britain

www.sinclair-world.com

This product was manufactured in China (Made in China).

REPRESENTATIVE

SINCLAIR Global Group s.r.o.

Purkynova 45

612 00 Brno

Czech Republic

TECHNICAL SUPPORT

SINCLAIR Global Group s.r.o.

Purkynova 45

612 00 Brno

Czech Republic

Tel.: +420 800 100 285 | Fax: +420 541 590 124

www.sinclair-solutions.com | info@sinclair-solutions.com





sinclair

AIR CONDITIONING