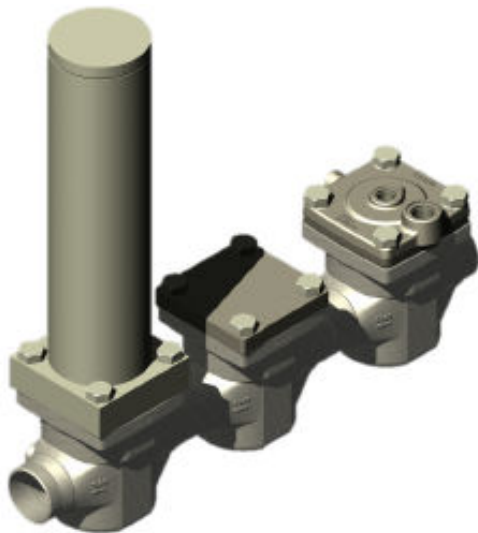


## Data Sheet

# Eco-Damper ICD damper, ICC Check valve and ICS control valve

(3 valve) system build on the ICV modular concept



The Danfoss Eco-damper solution is a 3 component (3 valve) system build on the ICV modular concept.

Each component consists of an ICV housing and 1 of 3 modules performing the functions Dampening (ICD), Non-return (ICC) and Control (ICS 1 or 3 pilots) respectively.

The Danfoss Eco-damper solution is used in the economizer line of typical screw compressors to dampen the pulsations from the compressor.

The Eco damper system is designed for high damping efficiency over a broad band of low frequencies with neglectable pressure drop.

It comes in sizes 32 and 50 and is offered from a parts program giving a wide variety of connection types and sizes.

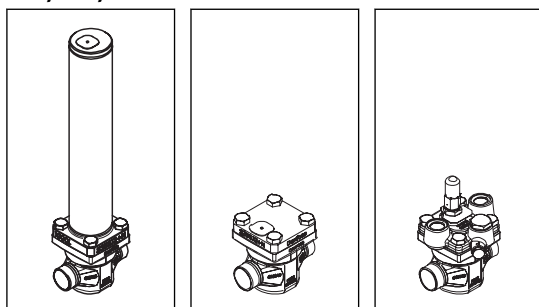
The ICD is a unique damping system combining the Helmholtz, Quarter wave and Expansion chamber principles into a broad band damper, able to reduce the Ammonia pulsations by 30% to 80% for critical frequencies in the frequency range of 100 to 500 Hz.

## Features

- Designed for Industrial Refrigeration applications for a maximum working pressure of 52 bar / 754 psig.
- Applicable to R717 (Ammonia)
- Direct welded connections
- Connection types include butt weld, socket weld and solder connections
- Low temperature steel body
- Low weight and compact design
- The 3 top covers can be turned in any of 4 orientations without affecting the individual functions
- Manual opening of the solenoid valve (ie. the line) possible
- Robust PTFE seat secures long lasting solenoid valve function
- Service friendly design

**Portfolio overview**

**ICD, ICC, ICS 32 & 50**

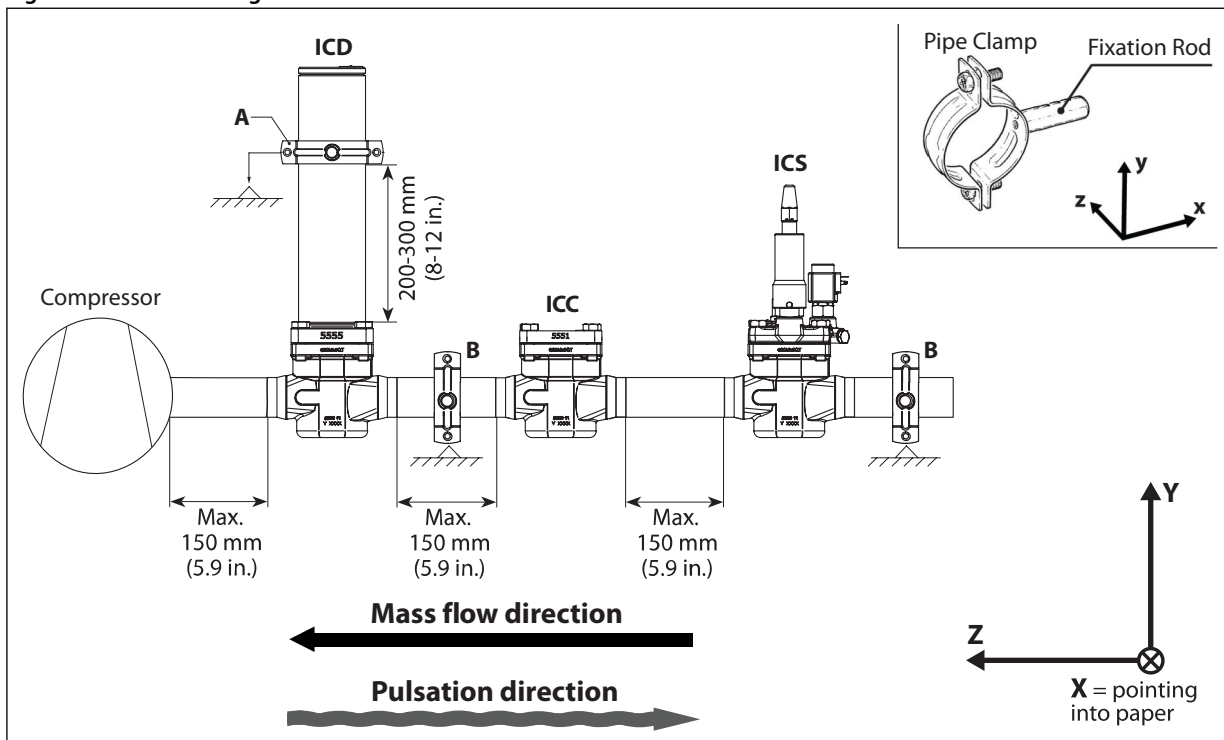


**Table 1: Portfolio overview**

Description	ICD, ICC, ICS 32	ICD, ICC, ICS 50
<b>Valve body/connection material</b>	Steel	Steel
<b>Connection standard</b>	EN 10220 ANSI (B 36.10) ANSI (B 16.11) EN 1254-1 ANSI (B 16.22)	EN 10220 ANSI (B 36.10) ANSI (B 16.11) EN 1254-1 ANSI (B 16.22)
<b>Connection type</b>	Butt weld Socket weld Solder connection	Butt weld Socket weld Solder connection
<b>Min. opening differential pressure</b>	ICS = 0,07 bar (1 psi) ICC = 0,04 bar (0.6 psi)	ICS = 0,07 bar (1 psi) ICC = 0,04 bar (0.6 psi)
<b>Pressure differential for fully opening of the ICS and ICC valves</b>	ICS = 0,2 bar (2.9 psi) ICC = 0,08 bar (1.2 psi)	ICS = 0,2 bar (2.9 psi) ICC = 0,08 bar (1.2 psi)
<b>K<sub>v</sub> (m<sup>3</sup>/h)</b>	ICC = 16.6 ICD = 17.7	ICC = 40.4 ICD = 39.4
<b>C<sub>v</sub> (USgal/min)</b>	ICC = 19.3 ICD = 20.6	ICC = 47 ICD = 45.9
<b>Temperature range</b>	ICD Temp. Range from -60 °C – 150 °C / -76 °F – 302 °F ICC Temp. Range from -60 °C – 120 °C / -76 °F – 248 °F ICS Temp. Range from -60 °C – 120 °C / -76 °F – 248 °F	ICD Temp. Range from -60 °C – 150 °C / -76 °F – 302 °F ICC Temp. Range from -60 °C – 120 °C / -76 °F – 248 °F ICS Temp. Range from -60 °C – 120 °C / -76 °F – 248 °F
<b>Max. working pressure</b>	52 bar / 754 psig	52 bar / 754 psig

## Functions

Figure 1: Functional diagram



Though the refrigerant flow in the economizer line is towards the compressor, the pulsations moves in the opposite direction. Due to this phenomenon the sequence of the 3 components is important. Seen from the compressor the dampening comes first followed by flow alignment and flow control.

It is equally important to orientate the valve housings with the arrow pointing in the mass flow direction (pointing towards the compressor).

Distances between the single components are of great importance and recommendations must be followed.

The Eco damper is designed for high efficiency dampening of pulsation pressure peeks and creating unidirectional flow in economizer lines of Ammonia systems.

Depending on the RPM's and geometry of the typical screw compressor the frequency and amplitude of the pulsations in the economizer lines will vary.

The ICD damper is specifically designed for dampening of the critical Ammonia pulsations in the broad band of 100 to 500 Hz.

A simple calculation will clarify if a certain compressor set-up will result in pulsation frequencies between 100 and 500 Hz and this clarification should be made before considering the Eco damper solution. Please look into the Selection section.

The ICD is a unique damping system combining the Helmholtz, Quarter wave and Expansion chamber principles into a broad band damper, able to reduce the Ammonia pulsations by 30% to 80% for critical frequencies in the specified frequency band.

The ICC non-return/check valve is a robust valve optimized to withstand pulsations in the same low frequency band. The ICC features the ability to reduce small pulsating movements in the wrong direction with an overall low pressure drop for the main flow direction.

The ICS control valve is the ordinary valve used for allround control purposes. In the Eco-Damper application the 3 pilot version is offered to be able to include more functions like solenoid and/ or pressure control. The solenoid function is the on/off function for the entire Eco-Damper.

The Eco-Damper solution must be assembled like shown in the above figure with the ICD next to the compressor followed by the ICC and finally the ICS.

**NOTE:**

In order to prevent exceeding vibrations caused by the ICD eigenfrequency, pipe clamps for fastening the ICD must be installed, and the max distances have to be followed (Figure 1: Functional diagram. Pos. A and B are mandatory). The pipe clamp for pos. A is included in the box. The B pipe clamps and the support must be strong and robust fixation points to help reduce vibrations.

As a guideline the values for stiffness of the clamp support can be found in following tables. For reference of coordinate system see Figure 1: Functional diagram. The pipe clamps at A and B have to provide the following minimum stiffness if the fixation rod is pointing in x-direction:

In N/mm	A	B
X	275.000	375.000
Y	14.000	36.000
Z	14.000	36.000

The pipe clamps at B have to provide the following minimum stiffness if the fixation rod is pointing in y-direction (clamp at A remains unchanged):

In N/mm	A	B
X	275.000	36.000
Y	14.000	375.000
Z	14.000	36.000

**Selection**

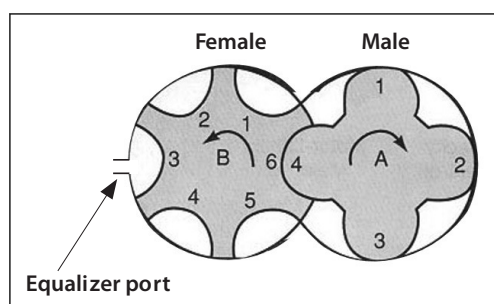
To determine the actual pulsation frequency of a compressor use this formula:

$$\text{Frequency} = \text{RPM (female)} * \text{number of grooves (female)} / 60 \text{ [Hz]}$$

**Example:** Frequency = 2000 \* 6 / 60 = 200 Hz

If 100 Hz < Frequency < 500 Hz dampening is possible with the Eco damper.

Further selection should be based on housing size, connection size and capacity.



**Capacity**

Once the frequency range is confirmed to be within damper range, the next step is to find the right valve capacity.

For selection and capacity calculation please refer to [Coolselector®2](#)

For application and compressor model confirmation please contact Danfoss.

Housing size	ICD connection size	ICC connection size
32	DN32	DN32
	DN40	DN40
50	DN50	DN50
	DN65	DN65

These criteria should be used for selection.

## Eco-Damper - ICD damper, ICC Check valve and ICS control valve

---

- Complete Eco-Damper solution (ICD+ICC): Lowest pressure drop @ min. and max. capacity
- Check ICC: Pressure drop min. @ minimum capacity (to be outside un-stable area) Check pressure drop max. @ maximum capacity
- Control/solenoid valve: Pressure drop @ min. and max. capacity
- Check control/solenoid valve: Pressure drop min. @ minimum capacity (to be outside un-stable area) Check pressure drop max. @ maximum capacity

**i NOTE:**

For assistance in relation to selection of right valve capacity please contact Danfoss.

## Media

### **Refrigerants**

Applicable to R717 (Ammonia)

### **New refrigerants**

Danfoss products are continually evaluated for use with new refrigerants depending on market requirements.

When a refrigerant is approved for use by Danfoss, it is added to the relevant portfolio, and the R number of the refrigerant (e.g. R513A) will be added to the technical data of the code number. Therefore, products for specific refrigerants are best checked at [store.danfoss.com/en/](https://store.danfoss.com/en/), or by contacting your local Danfoss representative.

## Product specification

### Pressure and temperature

Table 2: Pressure and temperature

<b>Max. temperature range</b>	Media: -60 °C – 120 °C / -76 °F – 248 °F.
<b>Max. working pressure</b>	52 bar / 754 psig
<b>Min. opening differential pressure</b>	ICS = 0,07 bar (1 psi) ICC = 0,04 bar (0.6 psi)
<b>Pressure differential for fully opening of the ICS and ICC valves</b>	ICS = 0,2 bar (2.9 psi) ICC = 0,08 bar (1.2 psi)
<b>K<sub>v</sub> (m<sup>3</sup>/h)</b>	<b>Size 32:</b> 17 <b>Size 50:</b> 44
<b>C<sub>v</sub> (USgal/min)</b>	<b>Size 32:</b> 20 <b>Size 50:</b> 51
<b>Coil requirement for ICS+EVM</b>	Coils to be IP67
<b>Damping frequency range</b>	100 – 500Hz
<b>Surface protection</b>	For excellent corrosion protection all valve outer surfaces are zinc-chromated. The Damper module is painted.

### Material specification

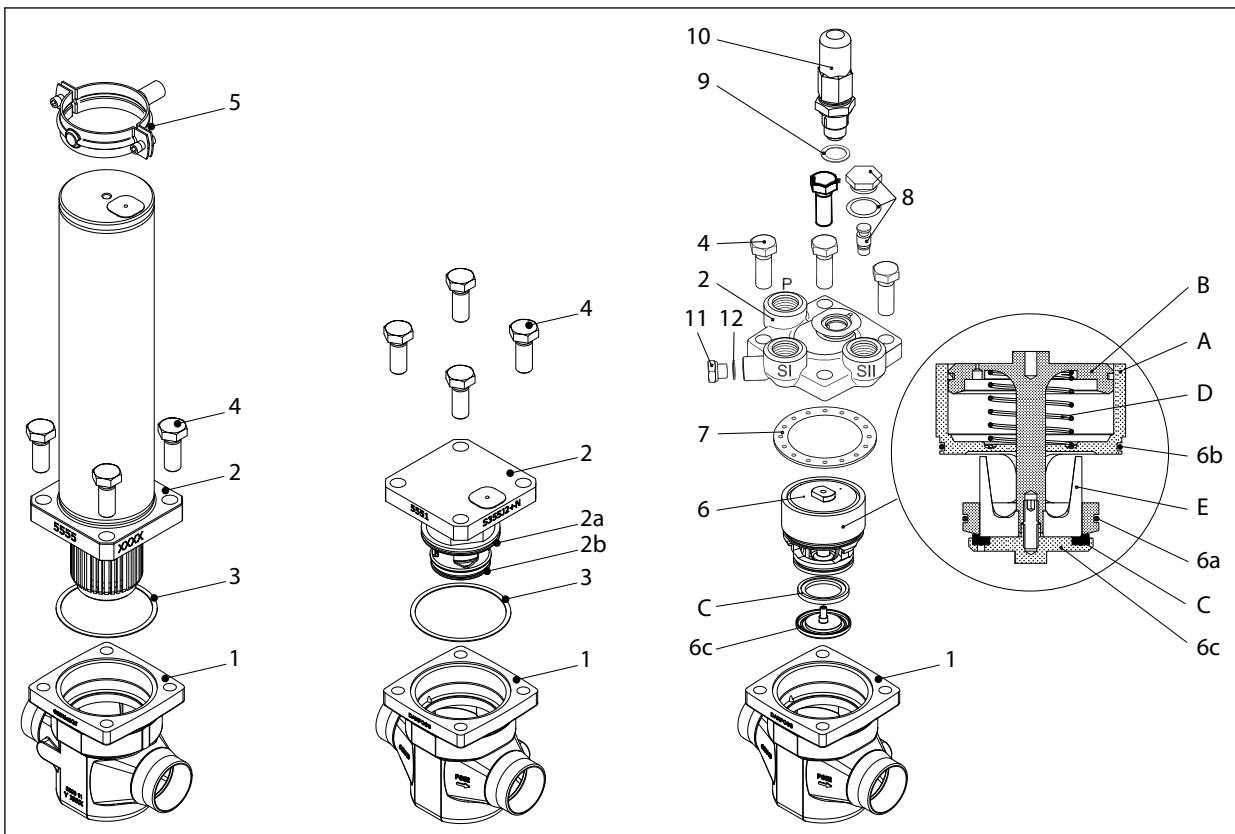


Table 3: Material specification

No	Part	Material	EN	ASTM	JIS
1	Body	Low temperature steel	G20Mn5QT EN 10213-3	LCC A352	SCPL1 G5151
2	Top assembly	Low temperature steel	G20Mn5QT, EN 10213-3 P285QH+QT 10222-4	LCC A352 LF2, A350	SCPL1 G5151
2a	O-ring	Cloroprene (Neoprene)			
2b	O-ring	Cloroprene (Neoprene)			
3	Gasket	Fiber, non-asbestos			
4	Bolts	Stainless steel	A2-70, EN 1515-1	Grade B8 A320	A2-70, B 1054



No	Part	Material	EN	ASTM	JIS
5	Pipe support	Stainless Steel			
6	Function module (assembled)				
6a	o-ring	Cloroprene (Neoprene)			
6b	o-ring	Cloroprene (Neoprene)			
6c	Washer plate	Steel			
A	Cylinder	Steel			
B	Piston	Steel			
C	Valve plate	PTFE			
D	Spring	Steel			
E	Cone	Steel			
7	Gasket	Fiber, non-asbestos			
8	Plug	Steel			
9	Gasket	Aluminium			
10	Manual operating spindle	Steel			
11	Plug	Steel			
12	Gasket	Aluminium			

## Connections

### The Eco-Damper concept

The Eco-Damper concept is developed to highest flexibility of direct welded connections. For valve sizes ICV 32 and 50 a wide range of connection sizes and types is available.

The direct welded (non-flanged) connections secures low risk of leakage.

Table 4: There are two valve bodies available



### There is a wide range of connection types available:

- **D**: Butt weld, EN 10220
- **A**: Butt weld, ANSI (B 36.10)
- **SOC**: Socket weld, ANSI (B 16.11)
- **SD**: Solder connection, EN 1254-1
- **SA**: Solder connection, ANSI (B 16.22)

Table 5: Design (valve)

D	A	SOC	SD	SA
Butt-weld DIN	Butt-weld ANSI	Socket weld ANSI	Solder DIN	Solder ANSI

## Dimensions and weights

### ICD 32 and 50

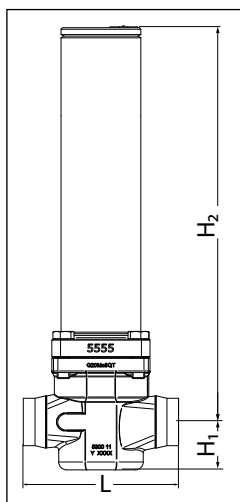


Table 6: Housing with module

Connection		H <sub>1</sub>	H <sub>2</sub>	L	Weight
32 D (1 1/4 in.)	mm	40	482.57	145	7 Kg
	in.	1.57	18.99	5.71	15.4 lbs
40 D (1 1/2 in.)	mm	40	482.57	145	6.8 Kg
	in.	1.57	18.99	5.71	14.9 lbs
32 A (1 1/4 in.)	mm	40	482.57	145	6.8Kg
	in.	1.57	18.99	5.71	15 lbs
40 A (1 1/2 in.)	mm	40	482.57	145	6.8 Kg
	in.	1.57	18.99	5.71	15.1 lbs
32 SOC (1 1/4 in.)	mm	40	482.57	148	6.9 Kg
	in.	1.57	18.99	5.83	15.3 lbs
35 SD (1 3/8 in. SA)	mm	40	482.57	148	6.8 Kg
	in.	1.57	18.99	5.83	14.9 lbs
42 SD (1 5/8 in.)	mm	40	482.57	148	6.8 Kg
	in.	1.57	18.99	5.83	14.9 lbs
42 SA (1 5/8 in.)	mm	40	482.57	148	6.8 Kg
	in.	1.57	18.99	5.83	14.9 lbs
50 D (2 in.)	mm	59	503.74	200	12.2 Kg
	in.	2.32	19.83	7.87	26.9 lbs
65 D (2 1/2 in.)	mm	59	503.74	210	12.6 Kg
	in.	2.32	19.83	8.27	27.8 lbs
50 A (2 in.)	mm	59	503.74	200	12.3 Kg
	in.	2.32	19.83	7.87	27.1 lbs
65 A (2 1/2 in.)	mm	59	503.74	210	12.6 Kg
	in.	2.32	19.83	8.27	27.8 lbs
50 SOC (2 in.)	mm	59	503.74	216	13.4 Kg
	in.	2.32	19.83	8.5	29.6 lbs
54 SD (2 1/8 in. SA)	mm	59	503.74	216	12.4 Kg
	in.	2.32	19.83	8.5	27.2 lbs

**NOTE:**

D = Butt-weld DIN ; A = Butt-weld ANSI ; J = Butt-weld JIS ; SOC = Socket weld ANSI ; SD = Solder DIN ; SA = Solder ANSI ; FPT = Female Pipe Thread

ICC 32 and 50

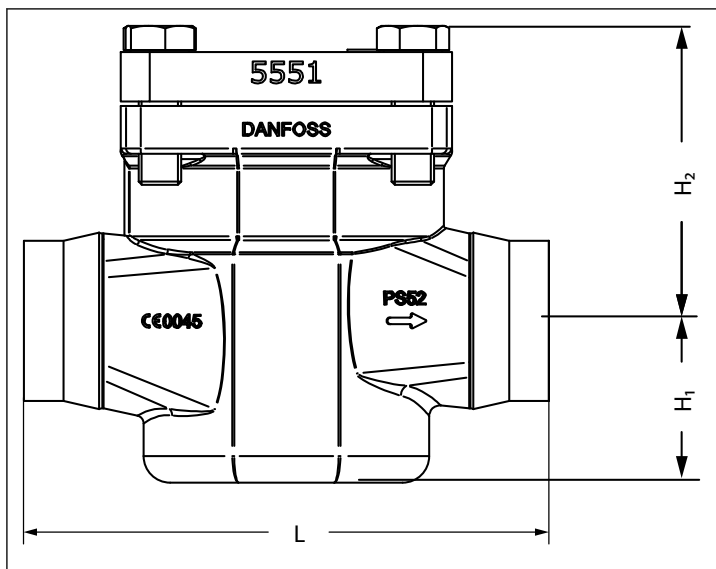


Table 7: Housing with top cover

Connection		H <sub>1</sub>	H <sub>2</sub>	L	Weight
32 D (1 1/4 in.)	mm	40	86.8	145	6.5 Kg
	in.	1.57	3.42	5.71	14.4 lbs
40 D (1 1/2 in.)	mm	40	86.8	145	6.6 Kg
	in.	1.57	3.42	5.71	14.6 lbs
32 A (1 1/4 in.)	mm	40	86.8	145	6.6 Kg
	in.	1.57	3.42	5.71	14.6 lbs
40 A (1 1/2 in.)	mm	40	86.8	145	6.7 Kg
	in.	1.57	3.42	5.71	14.7 lbs
32 SOC (1 1/4 in.)	mm	40	86.8	148	6.8 Kg
	in.	1.57	3.42	5.83	14.9 lbs
35 SD (1 3/8 in. SA)	mm	40	86.8	148	6.6 Kg
	in.	1.57	3.42	5.83	14.6 lbs
42 SD (1 5/8 in.)	mm	40	86.8	148	6.6 Kg
	in.	1.57	3.42	5.83	14.6 lbs
42 SA (1 5/8 in.)	mm	40	86.8	148	6.6Kg
	in.	1.57	3.42	5.83	14.6 lbs
50 D (2 in.)	mm	59	111.25	200	9.1 Kg
	in.	2.32	4.38	7.87	20 lbs
65 D (2 1/2 in.)	mm	59	111.25	210	9.5 Kg
	in.	2.32	4.38	8.27	20.9 lbs
50 A (2 in.)	mm	59	111.25	200	9.1 Kg
	in.	2.32	4.38	7.87	20.2 lbs
65 A (2 1/2 in.)	mm	59	111.25	210	9.5 Kg
	in.	2.32	4.38	8.27	20.9 lbs
50 SOC (2 in.)	mm	59	111.25	216	10.3 Kg
	in.	2.32	4.38	8.5	22.7 lbs
54 SD (2 1/8 in. SA)	mm	59	111.25	216	9.2 Kg
	in.	2.32	4.38	8.5	20.3 lbs

**NOTE:**

**D = Butt-weld DIN ; A = Butt-weld ANSI ; J = Butt-weld JIS ; SOC = Socket weld ANSI ; SD = Solder DIN ; SA = Solder ANSI ; FPT = Female Pipe Thread**

ICS 32 and 50

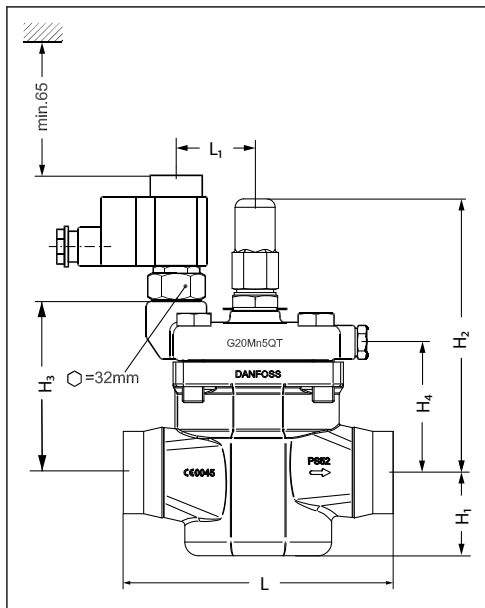


Table 8: Housing with module

Connection		H <sub>1</sub>	H <sub>2</sub>	H <sub>3</sub>	H <sub>4</sub>	L	L <sub>1</sub>	L <sub>2</sub>	B <sub>1</sub>	B <sub>2</sub>	Weight ICS 1 Pilot	Weight ICS 3 Pilots
32 D (1 1/4 in.)	mm	40	160	100	74	145	51	15	51	87	4.5 kg	5 kg
	in.	1.57	6.3	3.93	2.91	5.71	2	0.59	2	3.43	9.9 lb.	11 lb.
40 D (1 1/2 in.)	mm	40	160	100	74	145	51	15	51	87	4.5 kg	5 kg
	in.	1.57	6.3	3.93	2.91	5.71	2	0.59	2	3.43	9.9 lb.	11 lb.
32 A (1 1/4 in.)	mm	40	160	100	74	145	51	15	51	87	4.5 kg	5 kg
	in.	1.57	6.3	3.93	2.91	5.71	2	0.59	2	3.43	9.9 lb.	11 lb.
40 A (1 1/2 in.)	mm	40	160	100	74	145	51	15	51	87	4.5 kg	5 kg
	in.	1.57	6.3	3.93	2.91	5.71	2	0.59	2	3.43	9.9 lb.	11 lb.
32 SOC (1 1/4 in.)	mm	40	160	100	74	148	51	15	51	87	4.5 kg	5 kg
	in.	1.57	6.3	3.93	2.91	5.83	2	0.59	2	3.43	9.9 lb.	11 lb.
35 SD (1 3/8 in. SA)	mm	40	160	100	74	148	51	15	51	87	4.5 kg	5 kg
	in.	1.57	6.3	3.93	2.91	5.83	2	0.59	2	3.43	9.9 lb.	11 lb.
42 SD (1 5/8 in.)	mm	40	160	100	74	148	51	15	51	87	4.5 kg	5 kg
	in.	1.57	6.3	3.93	2.91	5.83	2	0.59	2	3.43	9.9 lb.	11 lb.
42 SA (1 5/8 in.)	mm	40	160	100	74	148	51	15	51	87	4.5 kg	5 kg
	in.	1.57	6.3	3.93	2.91	5.83	2	0.59	2	3.43	9.9 lb.	11 lb.
50 D (2 in.)	mm	59	181	120	93	200	51	15	63	91	8.9 kg	9.2 kg
	in.	2.32	7.13	4.72	3.66	7.87	2	0.59	2.48	3.58	19.6 lb.	20.2 lb.
65 D (2 1/2 in.)	mm	59	181	120	93	210	51	15	63	91	8.9 kg	9.2 kg
	in.	2.32	7.13	4.72	3.66	8.27	2	0.59	2.48	3.58	19.6 lb.	20.2 lb.
50 A (2 in.)	mm	59	181	120	93	200	51	15	63	91	8.9 kg	9.2 kg
	in.	2.32	7.13	4.72	3.66	7.87	2	0.59	2.48	3.58	19.6 lb.	20.2 lb.
65 A (2 1/2 in.)	mm	59	181	120	93	210	51	15	63	91	8.9 kg	9.2 kg
	in.	2.32	7.13	4.72	3.66	8.27	2	0.59	2.48	3.58	19.6 lb.	20.2 lb.
50 SOC (2 in.)	mm	59	181	120	93	216	51	15	63	91	8.9 kg	9.2 kg
	in.	2.32	7.13	4.72	3.66	8.5	2	0.59	2.48	3.58	19.6 lb.	20.2 lb.
54 SD (2 1/8 in. SA)	mm	59	181	120	93	216	51	15	63	91	8.9 kg	9.2 kg
	in.	2.32	7.13	4.72	3.66	8.5	2	0.59	2.48	3.58	19.6 lb.	20.2 lb.

**NOTE:**

**D = Butt-weld DIN ; A = Butt-weld ANSI ; J = Butt-weld JIS ; SOC = Socket weld ANSI ; SD = Solder DIN ; SA = Solder ANSI ; FPT = Female Pipe Thread**

## Ordering

### ICD, ICC, ICS 32

#### Ordering from the parts programme

Table 9: Example (select from table 10 to 13)

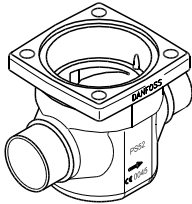
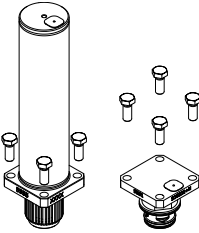
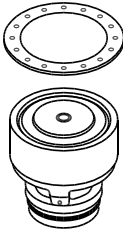
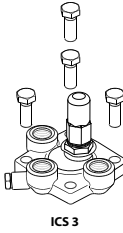
	+		+		+	
3 x Valve body 32 D (1 1/4 in.) <b>027H3120</b> Table 10		1 x Function module set ICD & ICC <b>027H3201</b> Table 11		1 x Function module ICS 32 <b>027H3200</b> Table 12		1 x Top cover 3 pilots <b>027H3173</b> Table 13

Figure 2: ICV 32 valve body

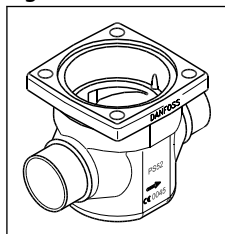


Table 10: ICV 32 valve body w/different connections

32 D (1 1/4 in.)	40 D (1 1/2 in.)	42 SA (1 5/8 in.)	42 SD (1 5/8 in.)
<b>027H3120</b>	<b>027H3125</b>	<b>027H3127</b>	<b>027H3128</b>
35 SD (1 3/8 in. SA)	32 A (1 1/4 in.)	32 SOC (1 1/4 in.)	40 A (1 1/2 in.)
<b>027H3123</b>	<b>027H3121</b>	<b>027H3122</b>	<b>027H3126</b>

**NOTE:**

**D = Butt-weld DIN ; A = Butt-weld ANSI ; J = Butt-weld JIS ; SOC = Socket weld ANSI ; SD = Solder DIN ; SA = Solder ANSI ; FPT = Female Pipe Thread**

Figure 3: ICD & ICC

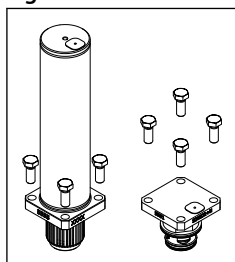


Table 11: ICD & ICC function module set

Description	Code Number
<b>ICD &amp; ICC 32</b>	<b>027H3201</b>

**NOTE:**

Including bolts, gaskets and o-rings

Figure 4: ICS 32

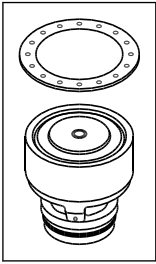


Table 12: ICS 32 function module

Description	Code Number
ICS 32	027H3200

**NOTE:**

Including gasket and O-rings

Figure 5: Top cover 1 Pilot    Figure 6: Top cover 3 Pilots

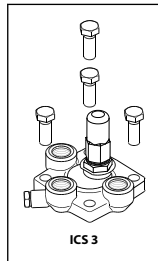
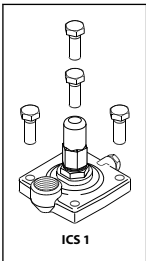


Table 13: ICS 32 top cover

Description	Code Number
Top cover 1 Pilot	027H3172 <sup>(1)</sup>
Top cover 3 Pilots	027H3173 <sup>(2)</sup>

<sup>(1)</sup> Including bolts

<sup>(2)</sup> Including bolts and one blanking plug

## ICD, ICC, ICS 50

### Ordering from the parts programme

Table 14: Example (select from table 15 to 18)

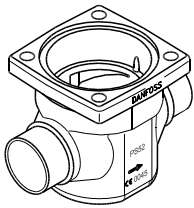
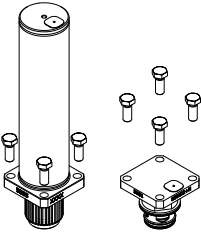
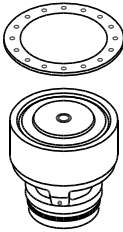
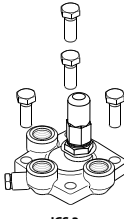
	+		+		+	
3 x Valve body 50 D (2 in.) <b>027H5120</b> <b>Table 15</b>		1 x Function module set ICD & ICC <b>027H5201</b> <b>Table 16</b>		1 x Function module ICS 50 <b>027H5200</b> <b>Table 17</b>		1 x Top cover 3 pilots <b>027H5173</b> <b>Table 18</b>

Figure 7: ICV 50 valve body

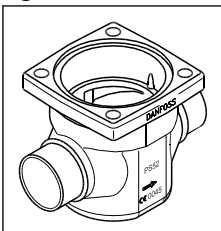


Table 15: ICV 50 valve body w/different connections

50 D (2 in.) <b>027H5120</b>	65 D (2½ in.) <b>027H5124</b>	54 SD (2 ⅛ in. SA) <b>027H5123</b>	50 A (2 in.) <b>027H5121</b>
50 SOC (2 in.) <b>027H5122</b>	65 A (2 ½ in.) <b>027H5125</b>		

**NOTE:**

**D = Butt-weld DIN ; A = Butt-weld ANSI ; J = Butt-weld JIS ; SOC = Socket weld ANSI ; SD = Solder DIN ; SA = Solder ANSI ; FPT = Female Pipe Thread**

Figure 8: ICD & ICC

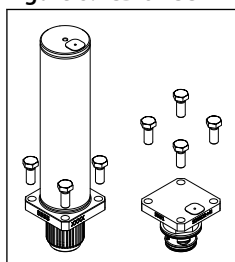


Table 16: ICD & ICC function module set

Description	Code Number
<b>ICD &amp; ICC 50</b>	<b>027H5201</b>

**NOTE:**

Including bolts, gaskets and o-rings

Figure 9: ICS 50

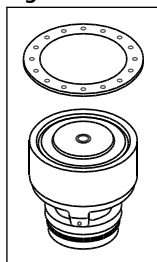


Table 17: ICS 50 function module

Description	Code Number
<b>ICS 50</b>	<b>027H5200</b>

**NOTE:**

Including gasket and O-rings

Figure 10: Top cover 1 Pilot    Figure 11: Top cover 3 Pilots

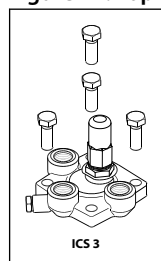
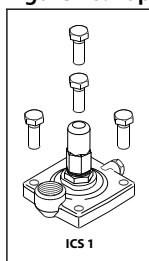


Table 18: ICS 50 top cover

Description	Code Number
<b>Top cover 1 Pilot</b>	<b>027H3172 <sup>(1)</sup></b>
<b>Top cover 3 Pilots</b>	<b>027H3173 <sup>(2)</sup></b>

<sup>(1)</sup> Including bolts

<sup>(2)</sup> Including bolts and one blanking plug

## Spare parts and accessories

Figure 12: Function module

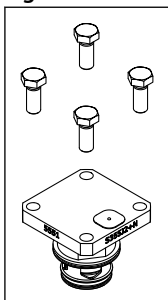


Table 19: Function module

Description	Code Number
ICC 32 function module	027H3202
ICC 50 function module	027H5202

Figure 13: Repair kit

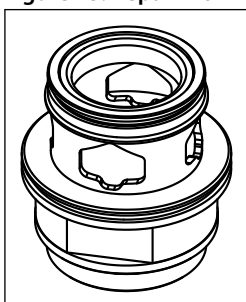


Table 20: Repair kit

Description	Code Number
ICC 32 repair kit	027H3039
ICC 50 repair kit	027H5017

**NOTE:**

Including bolts, gaskets and o-rings



**Certificates, declarations, and approvals**


The list contains all certificates, declarations, and approvals for this product type. Individual code number may have some or all of these approvals, and certain local approvals may not appear on the list.

Some approvals may change over time. You can check the most current status at danfoss.com or contact your local Danfoss representative if you have any questions.

The ICV valve concept is designed to fulfil global refrigeration requirements.

The individual components are CE, CRN and UL approved. For specific approval information, please contact Danfoss.

**Table 21: Compliance**

ICD, ICC and ICS valves		
	<b>Nominal bore</b>	DN 32 - 50 (1 1/4 - 2 in.)
	<b>Classified for</b>	Fluid group I
	<b>Category</b>	II

## Online support

Danfoss offers a wide range of support along with our products, including digital product information, software, mobile apps, and expert guidance. See the possibilities below.

### The Danfoss Product Store



The Danfoss Product Store is your one-stop shop for everything product related—no matter where you are in the world or what area of the cooling industry you work in. Get quick access to essential information like product specs, code numbers, technical documentation, certifications, accessories, and more.

Start browsing at [store.danfoss.com](https://store.danfoss.com).

### Find technical documentation



Find the technical documentation you need to get your project up and running. Get direct access to our official collection of data sheets, certificates and declarations, manuals and guides, 3D models and drawings, case stories, brochures, and much more.

Start searching now at [www.danfoss.com/en/service-and-support/documentation](https://www.danfoss.com/en/service-and-support/documentation).

### Get local information and support



Local Danfoss websites are the main sources for help and information about our company and products. Find product availability, get the latest regional news, or connect with a nearby expert—all in your own language.

Find your local Danfoss website here: [www.danfoss.com/en/choose-region](https://www.danfoss.com/en/choose-region).

### Danfoss Learning



Danfoss Learning is a free online learning platform. It features courses and materials specifically designed to help engineers, installers, service technicians, and wholesalers better understand the products, applications, industry topics, and trends that will help you do your job better.

Create your Danfoss Learning account for free at [www.danfoss.com/en/service-and-support/learning](https://www.danfoss.com/en/service-and-support/learning).

### Spare Parts



Get access to the Danfoss spare parts and service kit catalog right from your smartphone. The app contains a wide range of components for air conditioning and refrigeration applications, such as valves, strainers, pressure switches, and sensors.

Download the Spare Parts app for free at [www.danfoss.com/en/service-and-support/downloads](https://www.danfoss.com/en/service-and-support/downloads).

### Coolselector®2 - find the best components for you HVAC/R system



Coolselector®2 makes it easy for engineers, consultants, and designers to find and order the best components for refrigeration and air conditioning systems. Run calculations based on your operating conditions and then choose the best setup for your system design.

Download Coolselector®2 for free at [coolselector.danfoss.com](https://coolselector.danfoss.com).

### Danfoss A/S

Climate Solutions • [danfoss.com](https://danfoss.com) • +45 7488 2222

Any information, including, but not limited to information on selection of product, its application or use, product design, weight, dimensions, capacity or any other technical data in product manuals, catalogues descriptions, advertisements, etc. and whether made available in writing, orally, electronically, online or via download, shall be considered informative, and is only binding if and to the extent, explicit reference is made in a quotation or order confirmation. Danfoss cannot accept any responsibility for possible errors in catalogues, brochures, videos and other material. Danfoss reserves the right to alter its products without notice. This also applies to products ordered but not delivered provided that such alterations can be made without changes to form, fit or function of the product.

All trademarks in this material are property of Danfoss A/S or Danfoss group companies. Danfoss and the Danfoss logo are trademarks of Danfoss A/S. All rights reserved.