





**IMPORTANT NOTE:**

Read this manual carefully before installing or operating your new air conditioning unit. Make sure to save this manual for future reference.

# Table of Contents

<b>Part I : Technical Information</b> .....	<b>2</b>
<b>1. Summary</b> .....	<b>2</b>
<b>2. Specifications</b> .....	<b>3</b>
<b>3. Outline Dimension Diagram</b> .....	<b>7</b>
3.1 Indoor Unit.....	7
3.2 Outdoor Unit.....	7
<b>4. Refrigerant System Diagram</b> .....	<b>8</b>
<b>5. Electrical Part</b> .....	<b>9</b>
5.1 Wiring Diagram .....	9
5.2 PCB Printed Diagram .....	11
<b>6. Function and Control</b> .....	<b>13</b>
6.1 Remote Controller Introduction .....	13
6.2 Control Panel Introduction .....	15
6.3 Ewpe Smart App Operation Manual.....	16
6.4 Brief Description of Models and Functions .....	17
<b>7. Notes for Installation and Maintenance</b> .....	<b>20</b>
<b>Part II : Installation and Maintenance</b> .....	<b>20</b>
<b>8. Installation</b> .....	<b>24</b>
8.1 Accessory list.....	24
8.2 Before installation.....	24
8.3 Stick Sponge (Sealing Strip) And Sponge .....	24
8.4 Selecting an installation location .....	24
8.5 Mounting Outdoor Unit .....	26

8.6 Installing The Ceiling Assembly .....	26
8.7 Electrical Wiring.....	26
8.8 Completing The Installation .....	27
<b>9. Maintenance .....</b>	<b>28</b>
9.1 Error Code List.....	28
9.2 Procedure of Troubleshooting .....	29
<b>10. Exploded View and Parts List .....</b>	<b>36</b>
10.1 Indoor Unit.....	36
10.2 Outdoor Unit .....	37
<b>11. Removal Procedure .....</b>	<b>39</b>
11.1 Removal Procedure of Indoor Unit .....	39
11.2 Removal Procedure of Outdoor Unit.....	42
<b>Appendix .....</b>	<b>48</b>
Appendix 1: Reference Sheet of Celsius and Fahrenheit.....	48
Appendix 2: List of Resistance for Temperature Sensor.....	49



# 1. Summary

## Indoor Unit:

ASV-25BS  
ASV-35BS



## Outdoor Unit:

ASV-25BS  
ASV-35BS

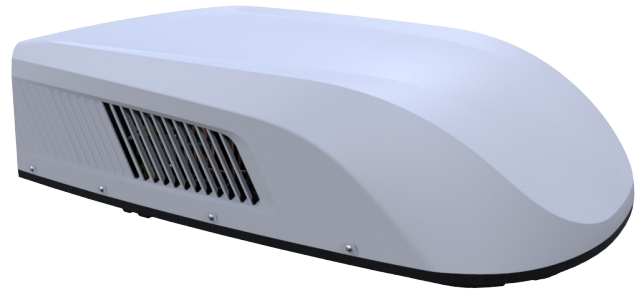

## Remote Controller:

YAY1F2



## 2. Specifications

Model		ASV-25BS	
Product Code		CU050001300	
Power Supply	Rated Voltage	V~	220-240
	Rated Frequency	Hz	50
	Phases		1
Cooling Capacity	W	2600	
Heating Capacity	W	2400	
Cooling Power Input	W	1160	
Heating Power Input	W	1000	
Cooling Current Input	A	/	
Heating Current Input	A	/	
Rated Input	W	1600	
Rated Current	A	/	
EER	W/W	/	
COP	W/W	/	
Air Flow Volume	m <sup>3</sup> /h	330/250/200	
Dehumidifying Volume	L/h	1	
Application Area	m <sup>2</sup>	10-17	
Set Temperature Range	°C	16~30	
Cooling Operation Ambient Temperature Range	°C	18~46	
Heating Operation Ambient Temperature Range	°C	-5~24	
Indoor Unit	Model		ASV-25BS
	Product Code		CU050N01300
	Swing Motor Model		/
	Swing Motor Power Output	W	/
	Fuse Current	A	3.15
	Dimension (WXHDXD)	mm	610X485X49
	Dimension of Carton Box (LXWXH)	mm	668X547X109
	Dimension of Package (LXWXH)	mm	678X550X112
	Net Weight	kg	2.7
	Gross Weight	kg	4
	Fan Type		Centrifugal
	Fan Diameter Length	mm	Φ150x177.5
	Cooling Speed	r/min	1680/1320/1100
Heating Speed	r/min	1680/1320/1100	
Fan Motor Power Output	W	38	
Fan Motor RLA	A	0.62	
Fan Motor Capacitor	μF	3.5	
Evaporator Form		Aluminum Fin-copper Tube	
Evaporator Pipe Diameter	mm	Φ7	
Evaporator Row-fin Gap	mm	3-1.4	
Evaporator Coil Length	mm	666×38.1×152.4	

Outdoor Unit	Model		ASV-25BS
	Product Code		CU050W01300
	Compressor Trademark		HIGHLY
	Compressor Manufacturer		SHANGHAI HIGHLY ELECTRICAL APPLIANCES CO.,LTD
	Compressor Model		GDD102SV-A3D
	Compressor Oil		ACS-68R
	Compressor Type		Rotary
	Compressor Locked Rotor Amp	A	18.9
	Compressor Rated Load Amp	A	3.85
	Compressor Power Input	W	828
	Compressor Overload Protector		Internal
	Fan Type		Centrifugal
	Fan Diameter	mm	Φ150
	Fan Motor Speed	rpm	1400
	Fan Motor Power Output	W	42
	Fan Motor RLA	A	0.38
	Fan Motor Capacitor	μF	3.5
	Air Flow Volume	m <sup>3</sup> /h	600
	Condenser Form		Aluminum Fin-copper Tube
	Condenser Pipe Diameter	mm	Φ7
	Condenser Rows-fin Gap	mm	3-1.4
	Condenser Coil Length	mm	552×38.1×228.6
	Permissible Excessive Operating Pressure for the Discharge Side	MPa	4.3
	Permissible Excessive Operating Pressure for the Suction Side	MPa	2.5
	Maximum Allowable Pressure	MPa	4.3
	Throttling Method		Capillary
	Climate Type		T1
	Isolation		I
	Moisture Protection		IPX4
	Refrigerant		R32
	Refrigerant Charge	kg	0.47
	Dimension (WXHDXD)	mm	1077X720X283
Dimension of Carton Box (LXWXH)	mm	1146X783X330	
Dimension of Package (LXWXH)	mm	1149X786X353	
Net Weight	kg	35	
Gross Weight	kg	44	

The above data is subject to change without notice. Please refer to the nameplate of the unit.

Model			ASV-35BS	
Product Code			CU050001400	
Power Supply	Rated Voltage	V~	220-240	
	Rated Frequency	Hz	50	
	Phases		1	
Cooling Capacity		W	3600	
Heating Capacity		W	3400	
Cooling Power Input		W	1270	
Heating Power Input		W	1170	
Cooling Current Input		A	/	
Heating Current Input		A	/	
Rated Input		W	1600	
Rated Current		A	/	
EER		W/W	/	
COP		W/W	/	
Air Flow Volume		m <sup>3</sup> /h	350/270/220	
Dehumidifying Volume		L/h	1	
Application Area		m <sup>2</sup>	10-17	
Set Temperature Range		°C	16~30	
Cooling Operation Ambient Temperature Range		°C	18~46	
Heating Operation Ambient Temperature Range		°C	-5~24	
Indoor Unit	Model		ASV-35BS	
	Product Code		CU050N01400	
	Swing Motor Model		/	
	Swing Motor Power Output		W	/
	Fuse Current		A	3.15
	Dimension (WXHxD)		mm	610X485X49
	Dimension of Carton Box (LXWXH)		mm	668X547X109
	Dimension of Package (LXWXH)		mm	678X550X112
	Net Weight		kg	2.7
	Gross Weight		kg	4
	Fan Type			Centrifugal
	Fan Diameter Length		mm	Φ150x177.5
	Cooling Speed		r/min	1680/1320/1100
	Heating Speed		r/min	1680/1320/1100
Fan Motor Power Output		W	38	
Fan Motor RLA		A	0.62	
Fan Motor Capacitor		μF	3.5	
Evaporator Form			Aluminum Fin-copper Tube	
Evaporator Pipe Diameter		mm	Φ7	
Evaporator Row-fin Gap		mm	3-1.4	
Evaporator Coil Length		mm	666×38.1×152.4	

Outdoor Unit	Model		ASV-35BS
	Product Code		CU050W01400
	Compressor Trademark		HIGHLY
	Compressor Manufacturer		SHANGHAI HIGHLY ELECTRICAL APPLIANCES CO.,LTD
	Compressor Model		GDD102SV-A3D
	Compressor Oil		ACS-68R
	Compressor Type		Rotary
	Compressor Locked Rotor Amp	A	18.9
	Compressor Rated Load Amp	A	3.85
	Compressor Power Input	W	828
	Compressor Overload Protector		Internal
	Fan Type		Centrifugal
	Fan Diameter	mm	Φ150
	Fan Motor Speed	rpm	1400
	Fan Motor Power Output	W	42
	Fan Motor RLA	A	0.38
	Fan Motor Capacitor	μF	3.5
	Air Flow Volume	m <sup>3</sup> /h	600
	Condenser Form		Aluminum Fin-copper Tube
	Condenser Pipe Diameter	mm	Φ7
	Condenser Rows-fin Gap	mm	3-1.4
	Condenser Coil Length	mm	552×38.1×228.6
	Permissible Excessive Operating Pressure for the Discharge Side	MPa	4.3
	Permissible Excessive Operating Pressure for the Suction Side	MPa	2.5
	Maximum Allowable Pressure	MPa	4.3
	Throttling Method		Capillary
	Climate Type		T1
	Isolation		I
	Moisture Protection		IPX4
	Refrigerant		R32
	Refrigerant Charge	kg	0.47
	Dimension (WXHDXD)	mm	1077X720X283
Dimension of Carton Box (LXWXH)	mm	1146X783X330	
Dimension of Package (LXWXH)	mm	1149X786X353	
Net Weight	kg	35	
Gross Weight	kg	44	

The above data is subject to change without notice. Please refer to the nameplate of the unit.

# 3. Outline Dimension Diagram

## 3.1 Indoor Unit

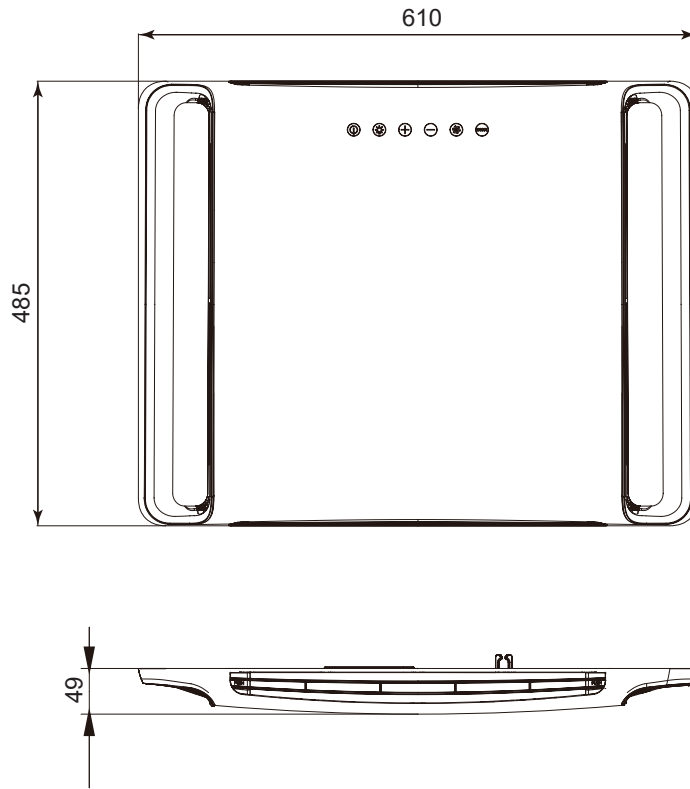

## 3.2 Outdoor Unit

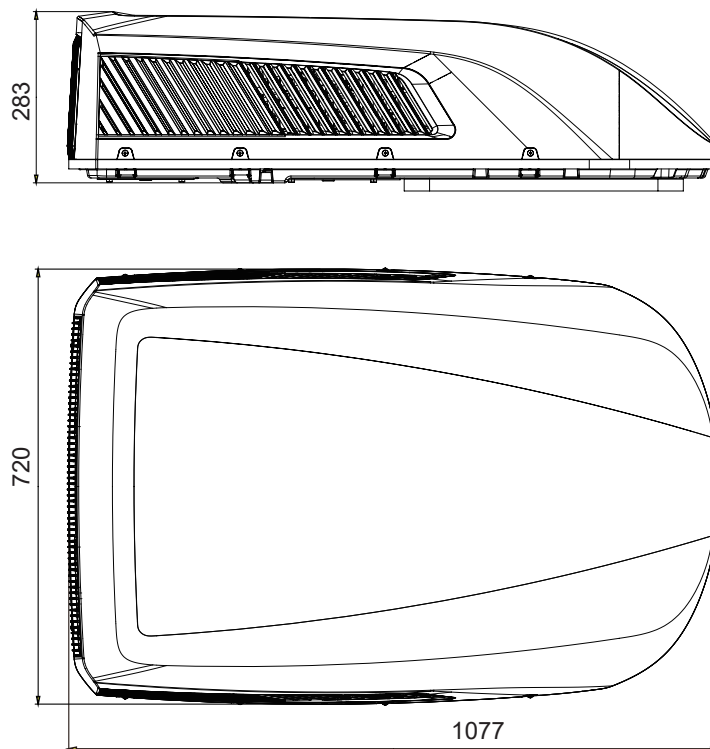

Unit:mm



# 4. Refrigerant System Diagram

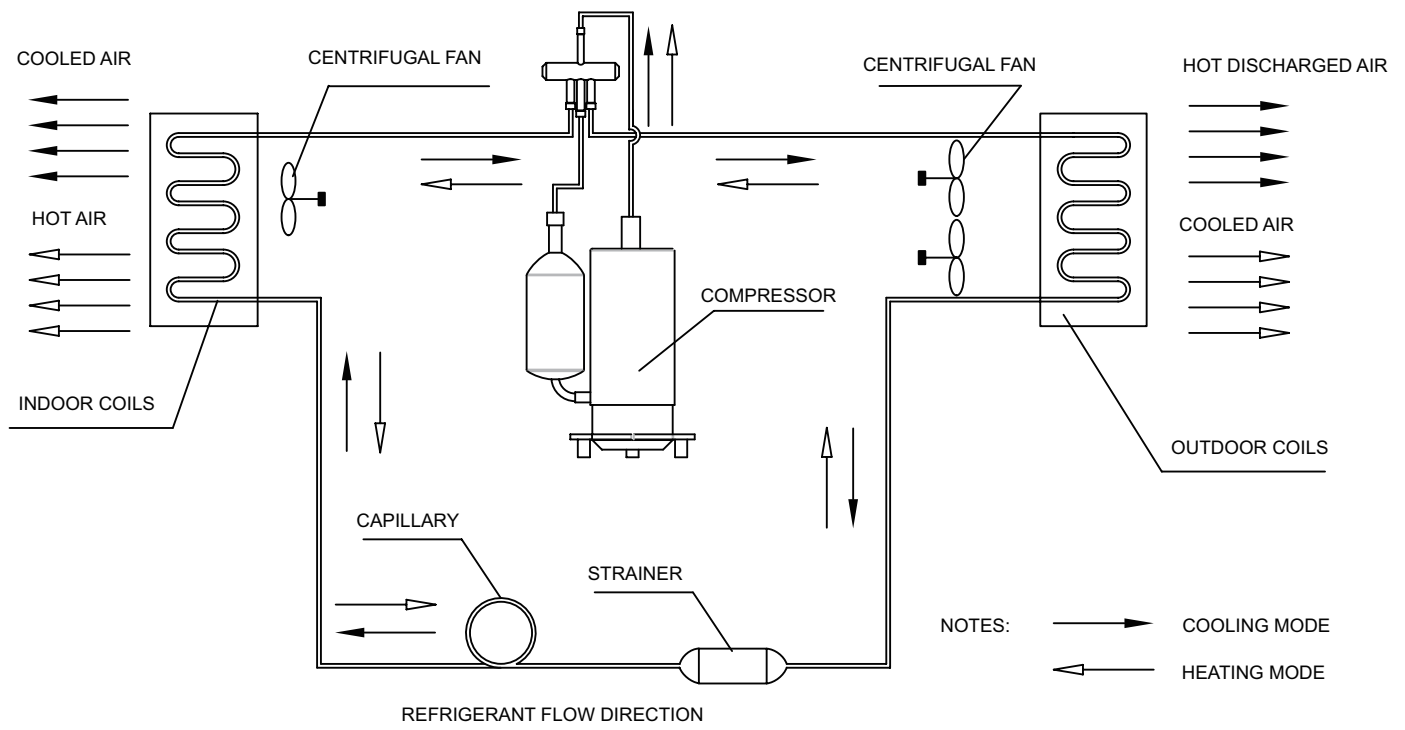

# 5. Electrical Part

## 5.1 Wiring Diagram

### •Instruction

Symbol	Symbol Color	Symbol	Symbol Color	Symbol	Name
WH	White	GN	Green	COMP	Compressor
YE	Yellow	BN	Brown		Grounding wire
RD	Red	BU	Blue	/	/
YEGN	Yellow/Green	BK	Black	/	/
VT	Violet	OG	Orange	/	/

### • Indoor Unit

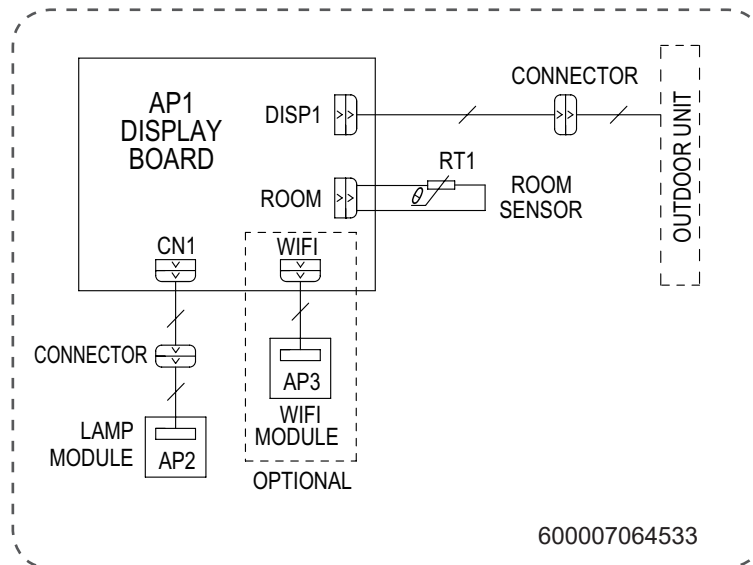

• Outdoor Unit

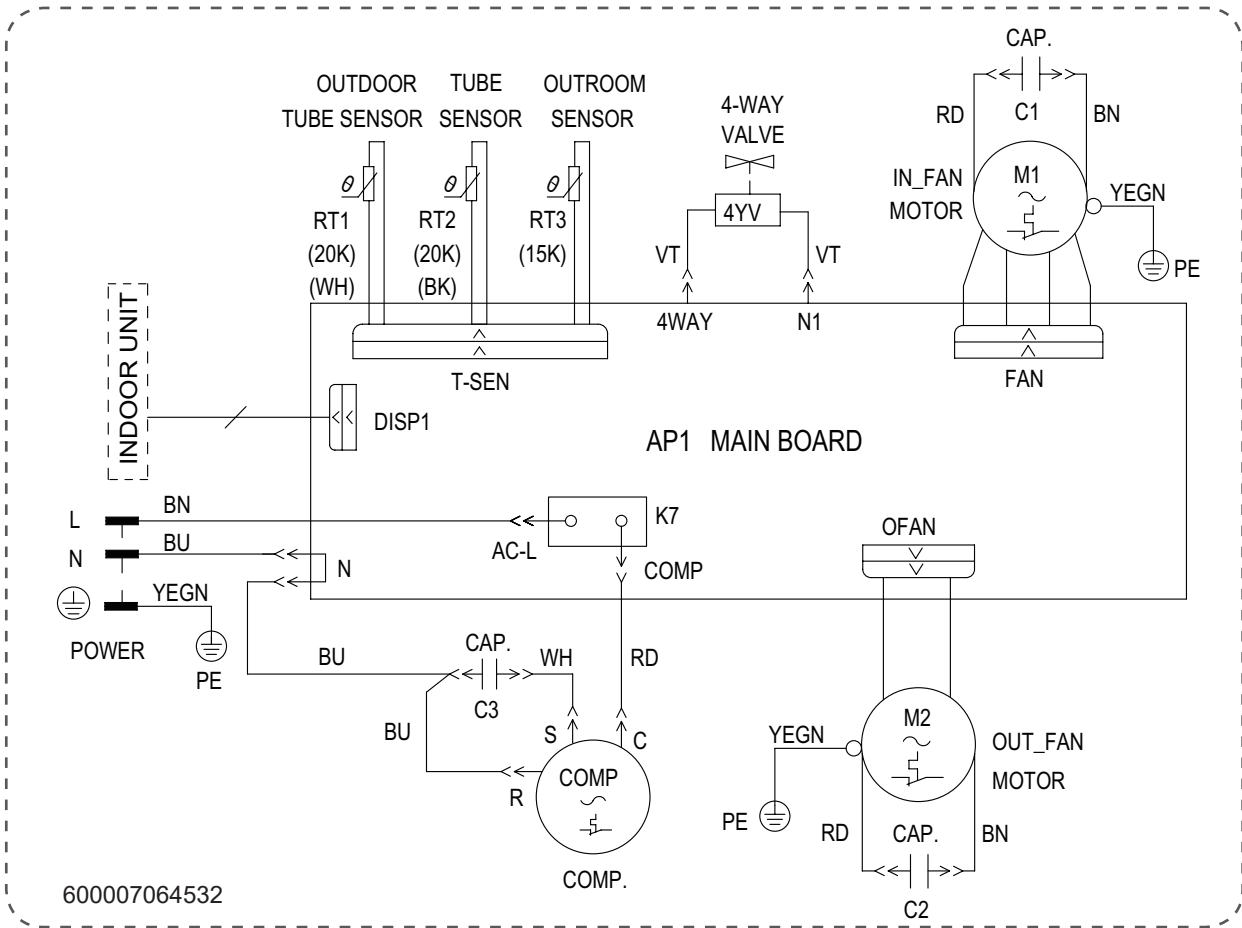

These wiring diagrams are subject to change without notice; please refer to the one supplied with the unit.

## 5.2 PCB Printed Diagram

### Silk screen on main board

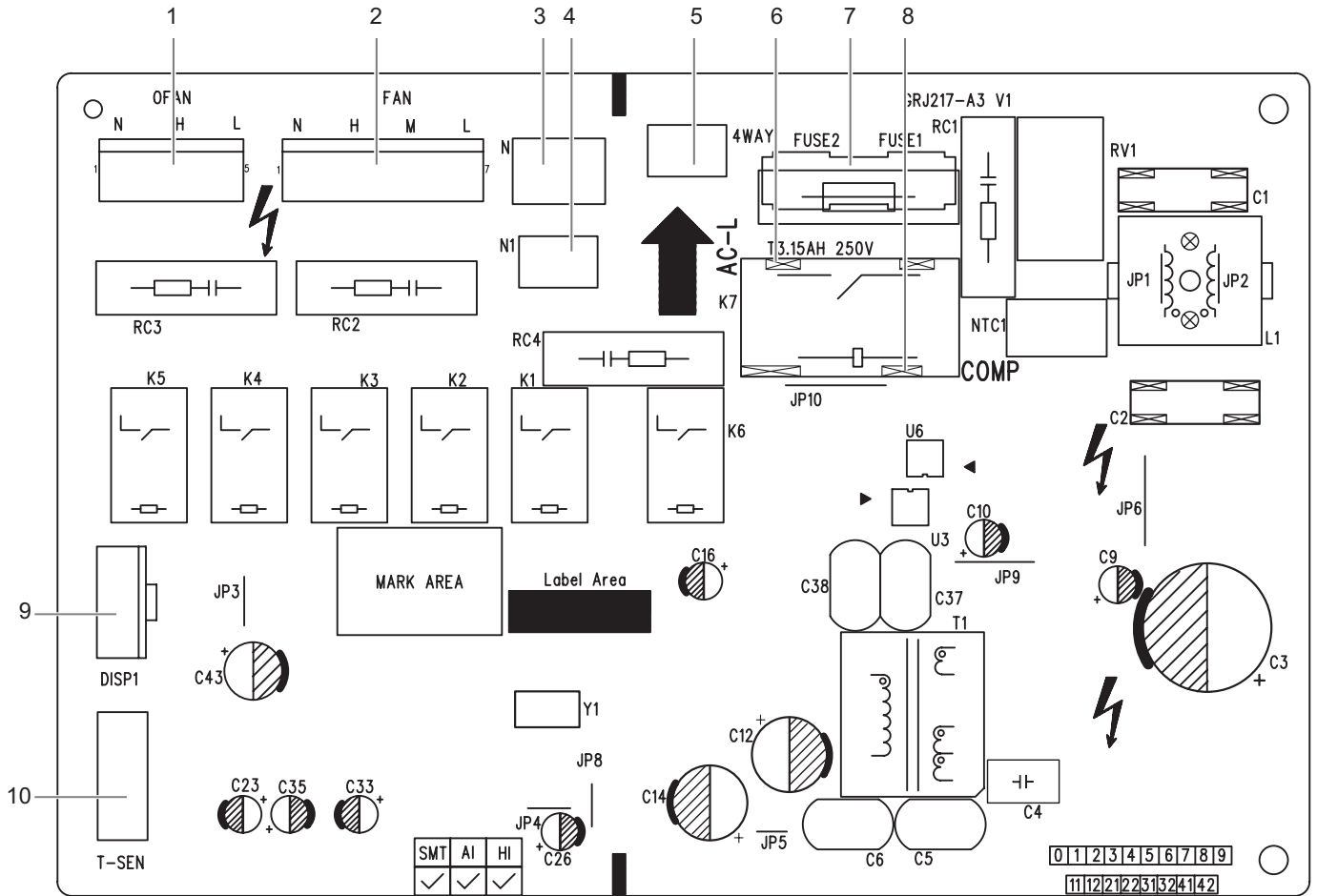

No.	Name
1	Control terminal of outdoor fan motor
2	Control terminal of indoor fan motor
3	Neutral wire terminal
4	Neutral wire terminal
5	Control terminal of 4-way valve

No.	Name
6	Live wire terminal
7	Fuse
8	Wiring terminal of compressore
9	Display terminal
10	Temperature sensor terminal

## Silk screen on display board

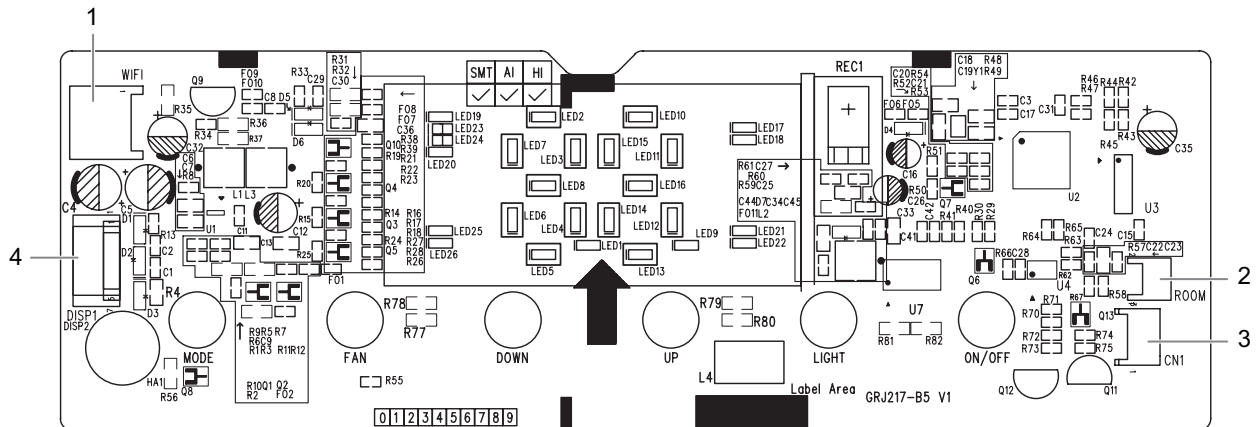

No.	Name	No.	Name
1	Interface of WiFi	3	Interface of lamp plate
2	Interface of temperature sensor	4	Interface of main board

# 6. Function and Control

## 6.1 Remote Controller Introduction

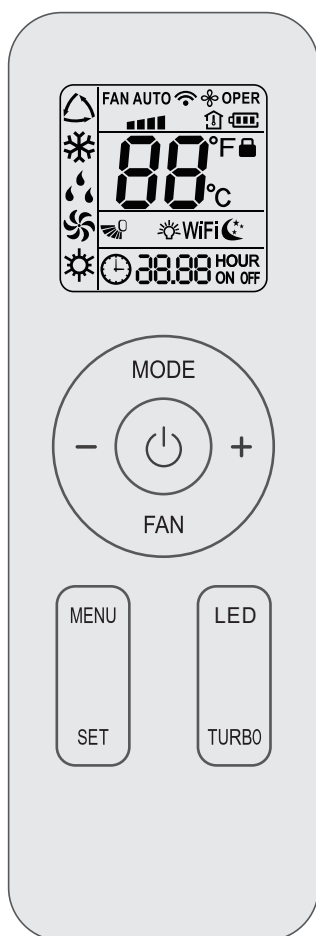

### Introduction for buttons on remote controller

#### Note:

- This is a general use remote controller. It could be used for the air conditioner with multifunction. For the functions which the model doesn't have, if press the corresponding button on the remote controller, the unit will keep the original running status.
- After putting through power, air conditioner will give out a sound and operation indicator "⏻" is ON (red indicator, the colour is different for different models). You can operate the air conditioner through the remote controller.
- Under on status, pressing the button on the remote controller, the signal icon "📶" on the display of remote controller will blink once and the air conditioner will give out a sound, which means the signal has been sent to the air conditioner.

#### ⏻ button

Press this button to turn on the unit. Press this button again to turn off the unit.

#### MODE button

Press this button to select your required operation mode.



- When selecting auto mode, air conditioner will operate automatically according to ambient temperature. Set temperature can't be adjusted and will not be displayed as well. Press "FAN" button can adjust fan speed.
- When selecting cool mode, air conditioner will operate under cool mode. Press "+" or "-" button to adjust set temperature. Press "FAN" button to adjust fan speed.
- When selecting dry mode, the air conditioner operates at low speed under dry mode. Under dry mode, fan speed can't be adjusted.
- When selecting fan mode, the air conditioner will only blow fan, no cooling and no heating. Press "FAN" button to adjust fan speed.
- When selecting heat mode, the air conditioner operates under heat mode. Press "+" or "-" button to adjust set temperature. Press "FAN" button to adjust fan speed.

#### \*NOTE:

For preventing cold air, after starting up heat mode, indoor unit will delay 1~5 minutes to blow air (Actual delay time depends on indoor ambient temperature). Set temperature range from remote controller: 16~30°C(61-86°F).

This mode indicator is not available for some models. Cooling only unit won't receive heat mode signal. If setting heat mode with remote controller, press "⏻" button can't start up the unit.

#### FAN button

This button is used for setting Fan Speed in the sequence that goes from AUTO, 📶, 📶, 📶 to 📶, then back to Auto.

#### \*NOTE:

Fan Speed "📶" is not available for some models, Fan Speed "📶" is the same with Fan Speed "📶" for some models. Under AUTO speed, air conditioner will select proper fan speed automatically according to factory default setting. AUTO speed is only available for some models.

It's low fan speed under dry mode.

X-FAN function: Holding fan speed button for 2s in cool or dry mode, the icon "⚙️" is displayed and the indoor fan will continue operation

### Introduction for icons on display screen

FAN AUTO	Set fan speed
📶	Send signal
⏻	Auto mode
❄️	Cool mode
💧	Dry mode
🌀	Fan mode
☀️	Heat mode
🌙	Sleep mode
💡	Light
⚙️	X-FAN function
🏠	Indoor ambient temp.
🕒	Clock
88°C	Set temperature
WIFI	WiFi function
88:88	Set time
ONOFF	TIMER ON / TIMER OFF
🌀	Up & down swing
🔒	Child lock



for a few minutes in order to dry the indoor unit even though you have turned off the unit. After energization, X-FAN OFF is defaulted. X-FAN is not available in auto, fan or heat mode. This function indicates that moisture on evaporator of indoor unit will be blown after the unit is stopped to avoid mould. Having set X-FAN function on: After turning off the unit by pressing "⏸" button, indoor fan will continue running for a few minutes at low speed. In this period, hold fan speed button for 2s to stop indoor fan directly. Having set X-FAN function off: After turning off the unit by pressing "⏸" button, the complete unit will be off directly. X-FAN function is only available for some models.

### —/+ button

Press "+" or "-" button once increase or decrease set temperature 1°C(°F). Holding "+" or "-" button, 2s later, set temperature on remote controller will change quickly. On releasing button after setting is finished, temperature indicator on indoor unit will change accordingly. (Temperature can't be adjusted under auto mode) When setting TIMER ON, TIMER OFF or CLOCK, press "+" or "-" button to adjust time. (Refer to CLOCK, TIMER ON, TIMER OFF functions).

### MENU/SET button

Press "MENU/SET" button to functions setting. Press "MENU" button to select the function setting symbol(the corresponding function symbol flashes). then press "SET" button to turn on or turn off this function. The submenu can be selected circularly as follows:

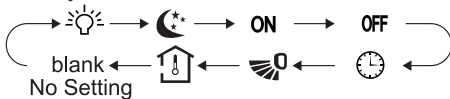

- ☀ :Light function
- ☾ :Sleep function
- ON : Timer on function
- OFF :Timer off function
- 🕒 :Clock function
- 🌀 :up and down swing function
- 🏠 :Ambient temperature display function

\*NOTE:Some menu's function may be unavailable under different models.

### LED button

Press this button can turn on or turn off the LED light on the panel.

### TURBO button

Under COOL or HEAT mode, press this button to turn to quick COOL or quick HEAT mode. "▬▬▬▬" icon is displayed on remote controller. If start this function, the unit will run at super-high fan speed to cool or heat quickly so that the ambient temperature approaches the preset temperature as soon as possible.

\*NOTE:  
Fan Speed "▬▬▬▬" is not available for some models, Fan Speed "▬▬▬▬" is the same with Fan Speed "▬▬▬▬" for some models.

## Function introduction for combination buttons

— and + :Child lock function

Press "+" and "-" simultaneously to turn on or turn off child lock function. When child lock function is on, "🔒" icon is displayed on remote controller. If you operate the remote controller, the "🔒" icon will blink three times without sending signal to the unit.

— and MODE :Temperature display switchover function

Under OFF status, press "-" and "MODE" buttons simultaneously to switch temperature display between °C and °F.

### MODE and TURBO :WiFi function

Press "MODE" and "TURBO" button simultaneously to turn on or turn off WiFi function. When WiFi function is turned on, the "WiFi" icon will be displayed on remote controller; Long press "MODE" and "TURBO" buttons simultaneously for 10s, remote controller will send WiFi reset code and then the WiFi function will be turned on. WiFi function is defaulted ON after energization of the remote controller.

\*NOTE:This function is only available for some models.

## Introduction for buttons on remote controller

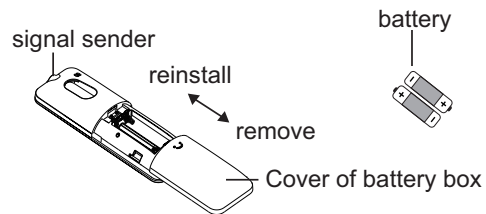

- 1.Press the back side of remote controller marked with "☺", as shown in the fig, and then push out the cover of battery box along the arrow direction.
- 2.Replace two 7# (AAA 1.5V) dry batteries, and make sure the position of "+" polar and "-" polar are correct.
- 3.Reinstall the cover of battery box.

### NOTICE

- During operation, point the remote control signal sender at the receiving window on indoor unit.
- The distance between signal sender and receiving window should be no more than 8m, and there should be no obstacles between them.
- Signal may be interfered easily in the room where there is fluorescent lamp or wireless telephone; remote controller should be close to indoor unit during operation.
- Replace new batteries of the same model when replacement is required.
- When you don't use remote controller for a long time, please take out the batteries.
- If the display on remote controller is fuzzy or there's no display, please replace batteries.

## 6.2 Control Panel Introduction

Note: If the remote controller is missing, operate on the control panel.

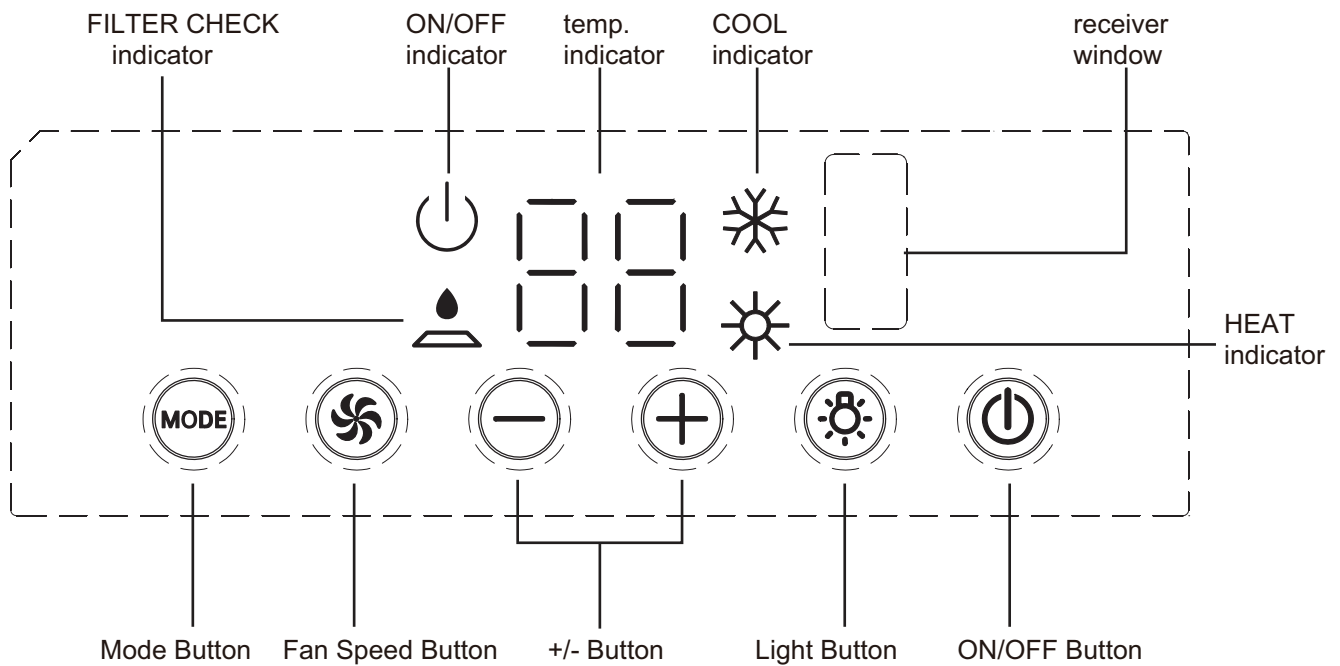

### Basic Functions of the Buttons

#### 1.ON/OFF button

Operation starts when pressing this button, and stops when pressing this button again.

#### 2.LIGHT button

Press this button to turn on or turn off display light on indoor unit.

#### 3.(+/-) button

Press the + button to increase the set(operating) temperature of the unit,and press the - button to decrease the set(operating) temperature of the unit. the temperature setting range is from 16~30°C (61~86°F).

#### 4.FAN SPEED button

Select the fan speed LOW, MED, HIGH and TURBO (This function is applicable to partial of models) in sequence.

#### 5.MODE button

Select the operation mode, COOL,FAN, HEAT.

#### 6.FILTER CHECK indicator

This feature is a reminder of cleaning the air filter(normal maintenance) for more efficient operation. The light will turn on automatically after the fan works more than 250 hours.

If the light is on, turn off and power off the unit, take the air filter out and clean it, then reinstall the air filter, power on and turn on the unit, the light will still be on, press + button for 5s,the light will turn off.

## 6.3 Ewpe Smart App Operation Manual

### Control Flow Chart

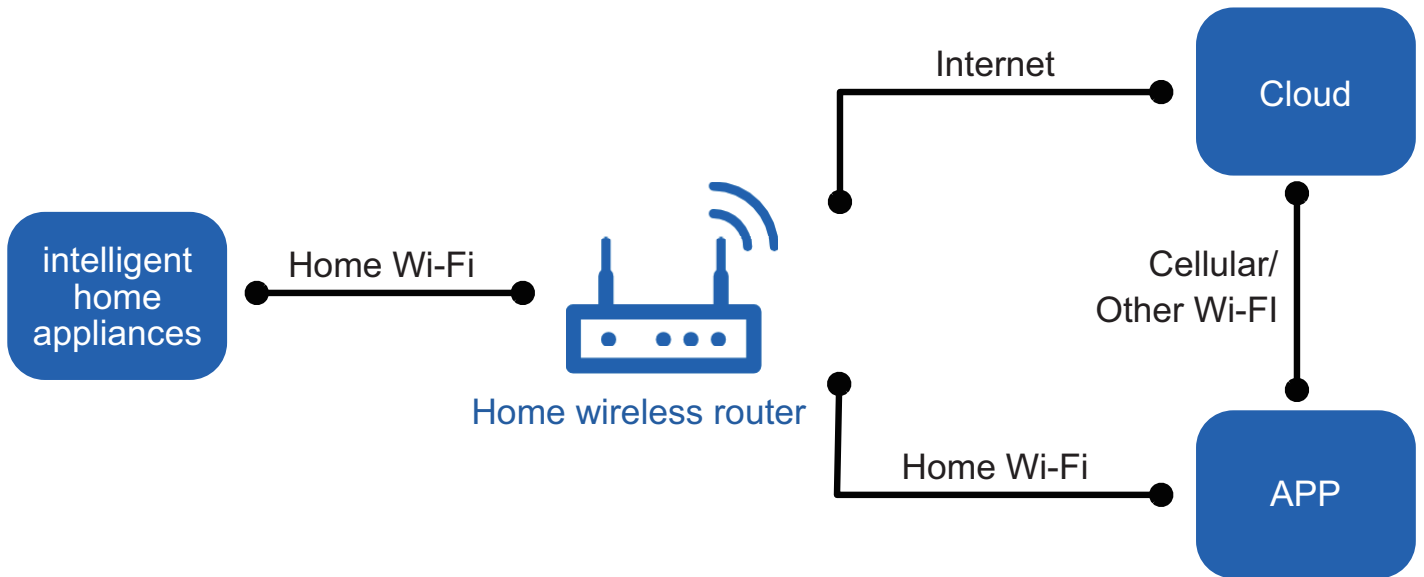

### Operating Systems

Requirement for User's smart phone:



iOS system  
Support iOS7.0 and  
above version



Android system  
Support Android 4.4 and  
above version

### Download and installation



App Download Linkage

Scan the QR code or search "Ewpe Smart" in the application market to download and install it. When "Ewpe Smart" App is installed, register the account and add the device to achieve long-distance control and LAN control of smart home appliances. For more information, please refer to "Help" in App.

## 6.4 Brief Description of Models and Functions

### 1. Target

Recreational Vehicles

### 2. Basic Functions

#### 2.1 Cooling

2.1.1 Operating conditions and procedures

- Tinner amb  $\geq$  Tpreset +1°C(2°F), cooling mode: compressor cycles on, fan motors will operate in set speed.
- Tinner amb  $\leq$  Tpreset -1°C(2°F), compressor and outdoor fan motors cycle off, indoor fan motor will operate in set speed.
- Tpreset -1°C(2°F) < Tinner amb < Tpreset +1°C(2°F), operates like before.

2.1.2 Temperature setting range is 16°C~30°C(61~86°F).

#### 2.2 Fan Only

2.2.1 In Fan Only, compressor and outdoor fan motors cycle off, indoor fan motor will operate in set speed.

2.2.2 Temperature setting range is 16°C~30°C(61~86°F).

#### 2.3 Heating

2.3.1 Heating conditions and process

- When Tamb.  $\leq$  Tset+1°C(2°F), the unit starts heating operation. In this case, the 4-way valve, compressor and outdoor fan motors run simultaneously; the indoor fan motor runs in cold air prevention condition.
- When Tamb.  $\geq$  Tset+3°C(6°F), the compressor and outdoor fan motors stop; the 4-way valve remains energized; the indoor fan motor blows resindooral heat;
- When Tset +1°C(2°F) < Tamb. < Tset+3°C(6°F), the unit will maintain its previous running status.

2.3.2 Temperature setting range is 16~30°C(61~86°F).

#### 2.4 Dehumidifying

2.4.1 Operating conditions and procedures

- Tinner amb > Tpreset +2°C(4°F), operates in Cooling mode, fan motors will operate in low speed.
- Tpreset -2°C(4°F)  $\leq$  Tinner amb  $\leq$  Tpreset+2°C(4°F), dehumidifier is on, indoor fan motor will operate in low speed. Compressor and outdoor fan motors will firstly on for 6 minutes and off for 4 minutes and then cycle on and off.
- Tinner amb < Tpreset -2°C(4°F), compressor and outdoor fan motors stop, indoor fan motor will operate in low speed.

2.4.2 Temperature setting range is 16~30°C(61~86°F).

#### 2.5 Auto

2.5.1 Operating conditions and procedures

- Tinner amb  $\geq$  26°C(79°F), cooling mode: Tpreset =25°C(77°F)
- Tinner amb < 22°C(72°F), if it is a Cooling and Warming controller, unit will operate in Warming mode, Tpreset = 20°C(68°F); if it is a Cooling controller, unit will operate in Fan Only, Tpreset =68°F(20°C);
- 22°C(72°F)  $\leq$  Tinner amb < 26°C(79°F), operates like before; if it is turned on for the first time, it will operate in Fan Only.

### 3. Other Functions

#### 3.1 Buzzer

When a controller is powered on or a signal is received from a remote controller or a button is pressed, buzzer will beep once.

#### 3.2 Sleeping Mode

1. In cooling and dry mode:

1.1 When the initial set temperature is 16-23°C(61~74°F), the temperature will rise 1°C(2°F) by every hour after sleep function is set; the temperature will not change after rising 3°C(6°F); after running for 7 hours, the temperature will decrease 1°C(2°F) and it will not change after that.

1.2 When the initial set temperature is 24-27°C(75~81°F), the temperature will rise 1°C(2°F) by every hour after sleep function is set; the temperature will not change after rising 2°C(4°F); after running for 7 hours, the temperature will decrease 1°C(2°F) and it will not change after that.

1.3 When the initial set temperature is 28-29°C(82~84°F), the temperature will rise 1°C(2°F) by every hour after sleep function is set; the temperature will not change after rising 1°C(2°F); after running for 7 hours, the temperature will decrease 1°C(2°F) and it will not change after that.

1.4 When the initial set temperature is 30°C(85~86°F), the unit will keep on running at this temperature; after running for 7 hours, the temperature will decrease 1°C(2°F) and it will not change after that.

2. In heating mode:

2.1 When the initial set temperature is 16°C(61~62°F), the unit will keep on running at this temperature;

2.2 When the initial set temperature is 17-20°C(63~68°F), the temperature will decrease 1°C(2°F) by every hour after sleep function is set; the temperature will not change after decreasing 1°C(2°F);

2.3 When the initial set temperature is 21-27°C(69~81°F), the temperature will decrease 1°C(2°F) by every hour after sleep function is set; the temperature will not change after decreasing 2°C(4°F);

2.4 When the initial set temperature is 28-30°C(82~86°F), the temperature will decrease 1°C(2°F) by every hour after sleep function is set; the temperature will not change after decreasing 3°C(6°F);

#### 3.3 Delay Timer

a) Timer On: when the air conditioner is off, it can be set automatically come on in 0.5h ~ 24h at its set mode.

b) Timer Off: when the air conditioner is on, it can be set automatically turn off in 0.5h ~ 24h.

If the time is set within 10 hours, the timing interval is 0.5h; If the time is set more than 10 hours, the timing interval is 1h.

### 3.4 Memory Function

The system will remember the settings when power is interrupted. The unit will automatically restart in the last setting used after the power is restored. If the air conditioner is on when power is interrupted, it takes 3 minutes for the compressor to restart after the power is restored. If the air conditioner is off when power is interrupted, there is no need to wait after power is restored.

### 3.5 Lights and Dual-8 Nixie Tube

- a. When unit is on and under cooling mode, the Cooling indicator will turn on while tube shows the set temperature. Temperature can be set;
- b. Under heating mode, the Heating indicator will turn on while tube shows the set temperature. Temperature can be set.
- c. When the power is on but the unit is off, the on/off indicator will turn on, and when unit is turned on, the on/off indicator will turn off.
- d. When unit is on and lights of all buttons on the remote controller go off, all set lights (except the LED light ) light and dual 8 nixie tubes will go off accordingly (except malfunction indicator and filter indicator). When the controller is receiving signals, the main board will remember the set parameter, which would be displayed after the remote light is turned on.

### 3.6 Temperature Setting

- (1) Temperature can be set by pressing the button +/- . Dual-8 nixie tube will show the temperature while setting.
- (2) The tube display can show degree Fahrenheit or degree Celsius. The default temperature reading on the display is degree Celsius. To change the display to degree Celsius, press the button + and - together and hold for 3 seconds. Repeat the process to change back to degree Fahrenheit.

### 3.7 Controls

- (1)ON/OFF: Turn air conditioner on and off. When air conditioner is off, press the button to turn it on. When air conditioner is on, press the button to turn it off;
- (2)FAN SPEED: Use to set the fan speed to FANL, FANM or FANH on the unit.
- (3)+/-: Use to set temperature and the delay time;
- (4)MODE: Use to switch different modes. it can be circulated to COOL,FAN,HEAT,COOL;
- (5)WIFI, TIMER and Sleeping mode can only be set by a remote controller.
- (6)Auto mode can only be set by a remote controller and displayed on it.
- (7) FILTER CHECK: This feature is a reminder of cleaning the air filter(normal maintenance) for more efficient operation. The light will turn on automatically after the fan works more than 250 hours. If the light is on, turn off and power off the unit, take the air filter out and clean it, then re-install the air filter, power on and turn on the unit, the light will still be on, press FILTER CHECK button,the light will turn off.
- (8)Light:Turn on or off the control panel display.
- (9) LED on the remote controller: As long as the unit is powered regardless of its on or off, press the button once to turn the LED light on or off. LED light can only be set by a remote controller. If the unit is powered the first time, LED light will turn on in the indoor panel.

### 3.8 Protection

#### 3.8.1 Temperature sensors' malfunctions detected

- (1) Indoor ambient temperature sensor is open/short-circuited: dual-8 nixie tube shows F1;
- (2) Indoor tube temperature sensor is open/short-circuited: dual-8 nixie tube shows F2;
- (3) Outdoor ambient temperature sensor is open/short-circuited: dual-8 nixie tube shows F3;
- (4) Outdoor tube temperature sensor is open/short-circuited: dual-8 nixie tube shows F4;
- (5)If different malfunctions occur at the same time, error codes will show in a circulated way

#### 3.8.2 Alarm Function of Filter

If the total operating time of the fan reaches 250 hours, the filter indicator will turn on to remind user to do the cleaning.

#### 3.8.3 Refrigerant loss protection' malfunctions detected

If the the unit enters refrigerant loss protection 6 times, the dual-8 nixie tube shows F0.

#### 3.8.4 Compressor overload protection' malfunctions detected

If the the unit enters compressor overload protection 6 times, the dual-8 nixie tube shows H3.

#### 3.8.5 Low voltage protection' malfunctions detected

If controller detects that system voltage lower than the limit value for 30s, the dual-8 nixie tube shows PL.

#### 3.8.6 Overload protection' malfunctions detected (in cooling or dehumidifying mode)

If it is detected that the unit enters overload protection 6 times because the condenser tube temperature is superheating in cooling or dehumidifying mode, the dual-8 nixie tube shows E8.

#### 3.8.7 Defrosting' malfunctions detected

For ensuring heating effect, air conditioner will defrost automatically according to defrosting status on outdoor unit. heating indicator flashes, 10 seconds and stop 0.5 seconds circularly.

## 4. Troubleshooting

### 4.1 Problem1: air conditioner does not start and the buzzer does not ring

What to do: check the air conditioner plug or replace the controllers.

**4.2 problem2:** dual 8 nixie tube shows F1;

What to do: make sure the indoor ambient temperature sensor is securely connected to the controller.

**4.3 Problem3:** dual-8 nixie tube shows F2;

What to do: the indoor tube temperature sensor is not securely connected with the controller. Install it again or replace it with a new one.

**4.4 problem4:** dual 8 nixie tube shows F3;

What to do: make sure the outdoor ambient temperature sensor is securely connected to the controller. Install it again or replace it with a new one.

**4.5 Problem5:** dual-8 nixie tube shows F4;

What to do: the outdoor tube temperature sensor is not securely connected with the controller. Install it again or replace it with a new one.

**4.6 Problem6:** dual-8 nixie tube shows F0.

What to do: check where the refrigerant leaks, repair the leakage and add the refrigerant according to experience.

**4.7 Problem7:** dual-8 nixie tube shows H3.

What to do: power off the unit , then power on and turn on the unit again few minutes later.

**4.8 Problem8:** dual-8 nixie tube shows PL; the unit stops except the LED light; cooling indicator flashes 2 seconds and stop 3 seconds circularly.

What to do: when cooling indicator stops flashing, press ON/OFF button once to turn the unit off and then turn on the unit again 2 minutes later.

**4.9 Problem9:** dual-8 nixie tube shows E8.

What to do: power off the unit , then power on and turn on the unit again few minutes later.

**4.10 Problem10:** dual-8 nixie tube shows JF.

What do to: confirm the connection between the WIFI detection board and the main board is correct and firm; install the WIFI inspection board again; replace the WIFI detection board with a new one with the same model; Replace the mainboard with the same model.



# 7. Notes for Installation and Maintenance

## Safety Precautions: Important!

Please read the safety precautions carefully before installation and maintenance.

The following contents are very important for installation and maintenance.

Please follow the instructions below.

- The installation or maintenance must accord with the instructions.
- Comply with all national electrical codes and local electrical codes.
- Pay attention to the warnings and cautions in this manual.
- All installation and maintenance shall be performed by distributor or qualified person.
- All electric work must be performed by a licensed technician according to local regulations and the instructions given in this manual.
- Be caution during installation and maintenance. Prohibit incorrect operation to prevent electric shock, casualty and other accidents.



## WARNINGS

### Electrical Safety Precautions:

1. Cut off the power supply of air conditioner before checking and maintenance.
2. The air condition must apply specialized circuit and prohibit share the same circuit with other appliances.
3. The air conditioner should be installed in suitable location and ensure the power plug is touchable.
4. Make sure each wiring terminal is connected firmly during installation and maintenance.
5. Have the unit adequately grounded. The grounding wire cant be used for other purposes.
6. Must apply protective accessories such as protective boards, cable-cross loop and wire clip.
7. The live wire, neutral wire and grounding wire of power supply must be corresponding to the live wire, neutral wire and grounding wire of the air conditioner.
8. The power cord and power connection wires cant be pressed by hard objects.
9. If power cord or connection wire is broken, it must be replaced by a qualified person.
10. If the power cord or connection wire is not long enough, please get the specialized power cord or connection wire from the manufacture or distributor. Prohibit prolong the wire by yourself.

11. For the air conditioner without plug, an air switch must be installed in the circuit. The air switch should be all-pole parting and the contact parting distance should be more than 3mm.

12. Make sure all wires and pipes are connected properly and the valves are opened before energizing.

13. Check if there is electric leakage on the unit body. If yes, please eliminate the electric leakage.

14. Replace the fuse with a new one of the same specification if it is burnt down; dont replace it with a cooper wire or conducting wire.

15. If the unit is to be installed in a humid place, the circuit breaker must be installed.

### Installation Safety Precautions:

1. Select the installation location according to the requirement of this manual.(See the requirements in installation part)
2. Handle unit transportation with care; the unit should not be carried by only one person if it is more than 20kg.
3. When installing the indoor unit and outdoor unit, a sufficient fixing bolt must be installed; make sure the installation support is firm.
4. Ware safety belt if the height of working is above 2m.
5. Use equipped components or appointed components during installation.
6. Make sure no foreign objects are left in the unit after finishing installation.

### Refrigerant Safety Precautions:

1. When refrigerant leaks or requires discharge during installation, maintenance, or disassembly, it should be handled by certified professionals or otherwise in compliance with local laws and regulations.
- 2.Avoid contact between refrigerant and fire as it generates poisonous gas; Prohibit prolong the connection pipe by welding.
3. Apply specified refrigerant only. Never have it mixed with any other refrigerant. Never have air remain in the refrigerant line as it may lead to rupture or other hazards.
4. Make sure no refrigerant gas is leaking out when installation is completed.
5. If there is refrigerant leakage, please take sufficient measure to minimize the density of refrigerant.
6. Never touch the refrigerant piping or compressor without wearing glove to avoid scald or frostbite.

**Improper installation may lead to fire hazard, explosion, electric shock or injury.**

## Safety Precautions for Refrigerant

●To realize the function of the unit, a special refrigerant circulates in the system. The used refrigerant is the fluoride R32, which is specially cleaned. The refrigerant is flammable and inodorous. Furthermore, it can lead to explosion under certain conditions. But the flammability of the refrigerant is very low. It can be ignited only by fire.

●Compared to common refrigerants, R32 is a nonpolluting refrigerant with no harm to the ozoneosphere. The influence upon the greenhouse effect is also lower. R32 has got very good thermodynamic features which lead to a really high energy efficiency. The units therefore need a less filling.

### WARNING:

- Appliance filled with flammable gas R32.
- Appliance shall be installed, operated and stored in a room with a floor area larger than 4 m<sup>2</sup>.
- The appliance shall be stored in a room without continuously operating ignition sources .  
( for example: open flames, an operating gas appliance or an operating electric heater.)
- The appliance shall be stored in a well-ventilated area where the room size corresponds to the room area as specified for operation.
- The appliance shall be stored so as to prevent mechanical damage from occurring.
- Ducts connected to an appliance shall not contain an ignition source.
- Keep any required ventilation openings clear of obstruction.
- Do not pierce or burn.
- Be aware that refrigerants may not contain an odour.
- Do not use means to accelerate the defrosting process or to clean, other than those recommended by the manufacturer.
- Servicing shall be performed only as recommended by the manufacturer.
- Should repair be necessary, contact your nearest authorized Service Centre.
- Any repairs carried out by unqualified personnel may be dangerous.
- Compliance with national gas regulations shall be observed. Read specialist's manual.

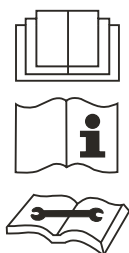

### Aptitude requirement for maintenance man(repairs should be done only be specialists).

- a. Any person who is involved with working on or breaking into a refrigerant circuit should hold a current valid certificate from an industry-accredited assessment authority, which authorises their competence to handle refrigerants safely in accordance with an industry recognised assessment specification.
- b.Servicing shall only be performed as recommended by the

equipment manufacturer. Maintenance and repair requiring the assistance of other skilled personnel shall be carried out under the supervision of the person competent in the use of flammable refrigerants.

### Safety preparation work

The maximum refrigerant charge amount is shown on the following table a.

(Note:Please refer to the nameplate for the charging quantity of R32).

table a - Maximum charge (kg)

Room area (m <sup>2</sup> )	4	8	10	12	15
Maximum charge (kg)	<1.224	1.346	1.683	2.019	2.448

Prior to beginning work on systems containing flammable refrigerants, safety checks are necessary to ensure that the risk of ignition is minimised. For repair to the refrigerating system, the following precautions shall be complied with prior to conducting work on the system.

### ●Work procedure

Work shall be undertaken under a controlled procedure so as to minimise the risk of a flammable gas or vapour being present while the work is being performed.

### ●General work area

All maintenance staff and others working in the local area shall be instructed on the nature of work being carried out. Work in confined spaces shall be avoided. The area around the workspace shall be sectioned off. Ensure that the conditions within the area have been made safe by control of flammable material

### ●Checking for presence of refrigerant

The area shall be checked with an appropriate refrigerant detector prior to and during work, to ensure the technician is aware of potentially toxic or flammable atmospheres.

Ensure that the leak detection equipment being used is suitable for use with all applicable refrigerants, i.e. non-sparking, adequately sealed or intrinsically safe.

### ●Presence of fire extinguisher

If any hot work is to be conducted on the refrigeration equipment or any associated parts, appropriate fire extinguishing equipment shall be available to hand. Have a dry powder or CO<sub>2</sub> fire extinguisher adjacent to the charging area.

### ●No ignition sources

No person carrying out work in relation to a refrigeration system which involves exposing any pipe work shall use any sources of ignition in such a manner that it may lead to the risk of fire or explosion. All possible ignition sources, including cigarette smoking, should be kept sufficiently far away from the site of installation, repairing, removing and disposal, during which refrigerant can possibly be released to the surrounding space. Prior to work taking place, the area around the equipment is to be surveyed to make sure that there are no flammable hazards or ignition risks. " NO Smoking " signs shall be displayed.

### ●Ventilated area

Ensure that the area is in the open or that it is adequately ventilated before breaking into the system or conducting any hot work. A degree of ventilation shall continue during the period

that the work is carried out. The ventilation should safely disperse any released refrigerant and preferably expel it externally into the atmosphere.

#### ●Checks to the refrigeration equipment

Where electrical components are being changed, they shall be fit for the purpose and to the correct specification. At all times the manufacturer's maintenance and service guidelines shall be followed. If in doubt, consult the manufacturer's technical department for assistance.

*The following checks shall be applied to installations using flammable refrigerants:*

- The actual refrigerant charge is in accordance with the room size within which the refrigerant containing parts are installed;
- The ventilation machinery and outlets are operating adequately and are not obstructed;
- If an indirect refrigerating circuit is being used, the secondary circuit shall be checked for the presence of refrigerant;
- Marking to the equipment continues to be visible and legible. Markings and signs that are illegible shall be corrected;
- Refrigeration pipe or components are installed in a position where they are unlikely to be exposed to any substance which may corrode refrigerant containing components, unless the components are constructed of materials which are inherently resistant to being corroded or are suitably protected against being so corroded.

#### ●Checks to electrical devices

Repair and maintenance to electrical components shall include initial safety checks and component inspection procedures. If a fault exists that could compromise safety, then no electrical supply shall be connected to the circuit until it is satisfactorily dealt with. If the fault cannot be corrected immediately but it is necessary to continue operation, an adequate temporary solution shall be used. This shall be reported to the owner of the equipment so all parties are advised.

##### Initial safety checks shall include:

1. That capacitors are discharged: this shall be done in a safe manner to avoid possibility of sparking;
2. That no live electrical components and wiring are exposed while charging, recovering or purging the system;
3. That there is continuity of earth bonding.

#### ●Repairs to sealed components

1. During repairs to sealed components, all electrical supplies shall be disconnected from the equipment being worked upon prior to any removal of sealed covers, etc. If it is absolutely necessary to have an electrical supply to equipment during servicing, then a permanently operating form of leak detection shall be located at the most critical point to warn of a potentially hazardous situation.
2. Particular attention shall be paid to the following to ensure that by working on electrical components, the casing is not altered in such a way that the level of protection is affected. This shall include damage to cables, excessive number of connections, terminals not made to original specification, damage to seals, incorrect fitting of glands, etc.

Ensure that the apparatus is mounted securely.  
Ensure that seals or sealing materials have not degraded to the point that they no longer serve the purpose of preventing the ingress of flammable atmospheres.

Replacement parts shall be in accordance with the manufacturer's specifications.

NOTE : The use of silicon sealant can inhibit the effectiveness of some types of leak detection equipment. Intrinsically safe components do not have to be isolated prior to working on them.

#### ●Repair to intrinsically safe components

Do not apply any permanent inductive or capacitance loads to the circuit without ensuring that this will not exceed the permissible voltage and current permitted for the equipment in use.

Intrinsically safe components are the only types that can be worked on while live in the presence of a flammable atmosphere. The test apparatus shall be at the correct rating.

Replace components only with parts specified by the manufacturer. Other parts may result in the ignition of refrigerant in the atmosphere from a leak.

#### ●Cabling

Check that cabling will not be subject to wear, corrosion, excessive pressure, vibration, sharp edges or any other adverse environmental effects. The check shall also take into account the effects of aging or continual vibration from sources such as compressors or fans.

#### ●Detection of flammable refrigerants

Under no circumstances shall potential sources of ignition be used in the searching for or detection of refrigerant leaks. A halide torch (or any other detector using a naked flame) shall not be used.

#### ●Leak detection methods

The following leak detection methods are deemed acceptable for all refrigerant systems.

Electronic leak detectors may be used to detect refrigerant leaks but, in the case of flammable refrigerants, the sensitivity may not be adequate, or may need re-calibration.

(Detection equipment shall be calibrated in a refrigerant-free area.) Ensure that the detector is not a potential source of ignition and is suitable for the refrigerant used.

Leak detection equipment shall be set at a percentage of the LFL of the refrigerant and shall be calibrated to the refrigerant employed, and the appropriate percentage of gas (25 % maximum) is confirmed.

Leak detection fluids are suitable for use with most refrigerants but the use of detergents containing chlorine shall be avoided as the chlorine may react with the refrigerant and corrode the copper pipe-work.

If a leak is suspected, all naked flames shall be removed/ extinguished.

If a leakage of refrigerant is found which requires brazing, all of the refrigerant shall be recovered from the system, or isolated (by means of shut off valves) in a part of the system remote from the leak. For appliances containing flammable refrigerants, oxygen free nitrogen (OFN) shall then be purged through the system both before and during the brazing process.

#### ●Removal and evacuation

When breaking into the refrigerant circuit to make repairs – or for any other purpose –conventional procedures shall be used. However, for flammable refrigerants it is important that best practice is followed since flammability is a consideration. The following procedure shall be adhered to:

1. remove refrigerant;
2. purge the circuit with inert gas; evacuate;
3. purge again with inert gas;
4. open the circuit by cutting or brazing.

The refrigerant charge shall be recovered into the correct recovery cylinders.

For appliances containing flammable refrigerants, the system shall be "flushed" with OFN to render the unit safe. This process may need to be repeated several times. Compressed air or oxygen

shall not be used for purging refrigerant systems.

For appliances containing flammable refrigerants, flushing shall be achieved by breaking the vacuum in the system with OFN and continuing to fill until the working pressure is achieved, then venting to atmosphere, and finally pulling down to a vacuum.

This process shall be repeated until no refrigerant is within the system. When the final OFN charge is used, the system shall be vented down to atmospheric pressure to enable work to take place. This operation is absolutely vital if brazing operations on the pipe-work are to take place.

Ensure that the outlet for the vacuum pump is not close to any ignition sources and that ventilation is available.

#### ●Charging procedures

In addition to conventional charging procedures, the following requirements shall be followed.

1. Ensure that contamination of different refrigerants does not occur when using charging equipment. Hoses or lines shall be as short as possible to minimise the amount of refrigerant contained in them.

2. Cylinders shall be kept upright.

3. Ensure that the refrigeration system is earthed prior to charging the system with refrigerant.

4. Label the system when charging is complete (if not already).

5. Extreme care shall be taken not to overfill the refrigeration system.

Prior to recharging the system, it shall be pressure-tested with the appropriate purging gas.

The system shall be leak-tested on completion of charging but prior to commissioning. A follow up leak test shall be carried out prior to leaving the site.

#### ●Decommissioning

Before carrying out this procedure, it is essential that the technician is completely familiar with the equipment and all its detail. It is recommended good practice that all refrigerants are recovered safely. Prior to the task being carried out, an oil and refrigerant sample shall be taken in case analysis is required prior to re-use of reclaimed refrigerant. It is essential that electrical power is available before the task is commenced.

a. Become familiar with the equipment and its operation.

b. Isolate system electrically.

c. Before attempting the procedure, ensure that:

- mechanical handling equipment is available, if required, for handling refrigerant cylinders;

- all personal protective equipment is available and being used correctly;

- the recovery process is supervised at all times by a competent person;

- recovery equipment and cylinders conform to the appropriate standards.

d. Pump down refrigerant system, if possible.

e. If a vacuum is not possible, make a manifold so that refrigerant can be removed from various parts of the system.

f. Make sure that cylinder is situated on the scales before recovery takes place.

g. Start the recovery machine and operate in accordance with manufacturer's instructions.

h. Do not overfill cylinders. (No more than 80 % volume liquid charge).

i. Do not exceed the maximum working pressure of the cylinder, even temporarily.

j. When the cylinders have been filled correctly and the process completed, make sure that the cylinders and the equipment are removed from site promptly and all isolation valves on the

equipment are closed off.

k. Recovered refrigerant shall not be charged into another refrigeration system unless it has been cleaned and checked.

#### ●Labelling

Equipment shall be labelled stating that it has been de-commissioned and emptied of refrigerant. The label shall be dated and signed. For appliances containing flammable refrigerants, ensure that there are labels on the equipment stating the equipment contains flammable refrigerant.

#### ●Recovery

When removing refrigerant from a system, either for servicing or decommissioning,

it is recommended good practice that all refrigerants are removed safely.

When transferring refrigerant into cylinders, ensure that only appropriate refrigerant recovery cylinders are employed. Ensure that the correct number of cylinders for holding the total system charge are available. All cylinders to be used are designated for the recovered refrigerant and labelled for that refrigerant (i.e. special cylinders for the recovery of refrigerant). Cylinders shall be complete with pressure-relief valve and associated shutoff valves in good working order. Empty recovery cylinders are evacuated and, if possible, cooled before recovery occurs.

The recovery equipment shall be in good working order with a set of instructions concerning the equipment that is at hand and shall be suitable for the recovery of all appropriate refrigerants including, when applicable, flammable refrigerants. In addition, a set of calibrated weighing scales shall be available and in good working order. Hoses shall be complete with leak-free disconnect couplings and in good condition. Before using the recovery machine, check that it is in satisfactory working order, has been properly maintained and that any associated electrical components are sealed to prevent ignition in the event of a refrigerant release. Consult manufacturer if in doubt.

The recovered refrigerant shall be returned to the refrigerant supplier in the correct recovery cylinder, and the relevant waste transfer note arranged. Do not mix refrigerants in recovery units and especially not in cylinders.

If compressors or compressor oils are to be removed, ensure that they have been evacuated to an acceptable level to make certain that flammable refrigerant does not remain within the lubricant.











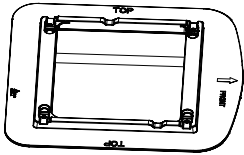

The evacuation process shall be carried out prior to returning the compressor to the suppliers. Only electric heating to the compressor body shall be employed to accelerate this process.

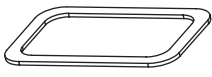
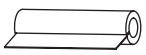
When oil is drained from a system, it shall be carried out safely

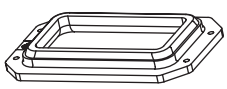

# 8. Installation

## 8.1 Accessory list

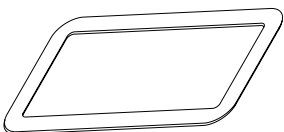
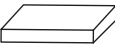
 owner's manual	 Mounting plate
 Double-sided gummed paper	 Remote controller holder
 Foam (accessory)	 Sponge (foam accessory)
 Insulating sheath	 Bundle (2)
 remote controller	 battery (2) (AAA 1.5V)
 Sunk screw (2) (remote controller holder)	 Foam (up)
 Mounting plate sub-assy	 Bolt sub-assy M8X135 (4)
 Bolt sub-assy(4)M6X25	 Tapping screw(8)
 Sponge (sealing strip)	 Sponge(3)

## 8.2 Before installation

Test run the unit with proper power supply. Refer to the operation instruction section in the Owner's Manual Operation & Installation. Make sure all the controls operate correctly then disconnect the power supply of the unit.

### ⚠ WARNING

1. Moving parts may cause personal injury. Be careful when test the unit. Do not operate the unit with exterior cover removed.
2. Outdoor unit can't be installed at the low recess of the roof of vehicle. It must be mounted at the flat surface on the roof of vehicle to make sure the rain, car-washing water, condensate water, etc. can be drained smoothly. No water is allowed to be accumulated around the outdoor unit; otherwise, it will cause malfunction or safety hazards as the water will pour into the air conditioner.
3. Please use the equipped mounting Plate for installation; otherwise, it may cause malfunction or damage.

## 8.3 Stick Sponge (Sealing Strip) And Sponge

1. Before sticking, clean up the sundries at the sticking position (as shown in Fig.1) of the chassis of the outdoor unit to ensure that the sticking position is clean;
  2. Take out one piece of sponge (sealing strip) and three pieces of sponge from the accessories, and tear off the paper on the glue surface and align at the edge of the position as shown in Fig.1 to stick the sponge.
- If the sponge (sealing strip) is damaged or not stuck on the proper position, you must replace it with a new one and stick it properly;
3. Check whether the sponge (sealing strip) and the sponge are tightly adhered, and ensure that they will not fall off.

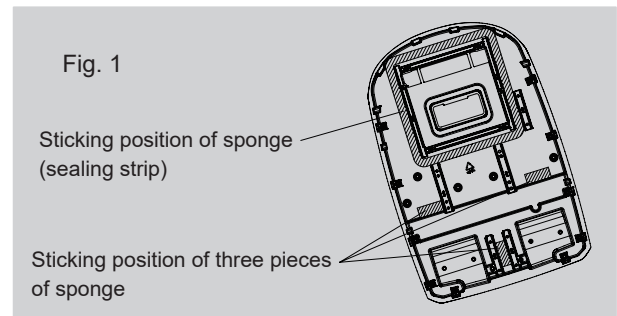

## 8.4 Selecting an installation location

The air conditioner has been designed for use in recreational vehicles.

Check the roof of the vehicle to determine if it can support both the roof top unit and the ceiling assembly without additional support. Make sure the interior ceiling mounting area will not interfere with existing structures.

Once the location for the air conditioner has been determined. A reinforced and framed roof hole opening must be cut (if there is no hole, please refer to CASE B) or you may use existing vent holes (See CASE A).

### CASE A.

If a roof vent is already present in the desired mounting location for the air conditioner, the following steps must be performed:

1. Remove all screws which secure the roof vent to the vehicle. Remove the vent and any additional trim. Carefully remove all chalking from around the opening so the surface is clear.
2. It may be necessary to seal some of the old roof vent mounting screw holes which may fall outside of the air conditioner basepan

gasket.

3. Examine the roof opening size, if the opening is small than 400x400mm, the opening must be enlarged.

**CASE B.**

If a roof vent opening is not used, a new opening (see Fig. 2) will be cut into the vehicle roof. A matching opening will also have to be cut into the interior vehicle ceiling, be careful when cutting the ceiling opening because if the ceiling opening is carpeted, snagging could occur. After the opening in the roof and interior ceiling are the correct size, a framed support structure must be placed between the exterior roof top and interior ceiling. The reinforced framed structure must follow the following guidelines:

1. It must be capable of supporting both the weight of the roof top air conditioner and the interior ceiling assembly.
2. It must be capable of holding the roof outer surface and interior ceiling apart and supporting them, so that when the roof top air conditioner and ceiling assembly are bolted together, no collapsing occurs. A typical support frame is shown in Fig. 2.
3. There must be an opening through the frame for the power supply wiring. Route the supply wiring through the frame at the same time the support frame is being installed.

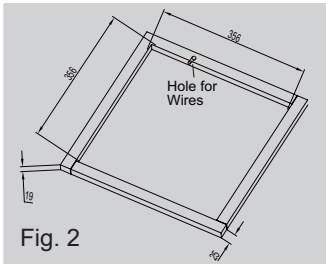

**Installation method for mounting plat**

If the roof already has a 400x400mm opening.

Select the installation position for the recreational vehicle air conditioner

This mounting plat of switchover opening is applicable for Sinclair recreational vehicle air conditioner.

The opening size of installation port on the top of the vehicle must be 400x400mm.

**Operation method:**

1. Eliminate the sundries around the installation port on the top of the vehicle and keep the installation surface flat;
2. Check whether there are holes or grooves on surface of installation position. If yes, conduct the sealing treatment to prevent water leakage;
3. Fill the groove on the surface where the mounting plate is contacting the top part of the vehicle with the unhardened sealant (the maximum thickness is 1cm); When the mounting plat is installed on the top of vehicle, fill the sealant in the gap between the mounting plat and the vehicle roof. The mounting plat should be tightly sealed with the roof of the vehicle to prevent water leakage.
4. Install it into the opening on the top of the vehicle according to the indicate direction by the arrow (the direction of arrow should be the same with the head of the vehicle).

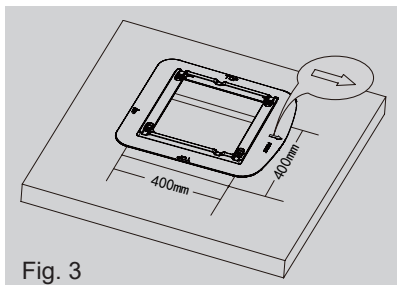

**CAUTION**

1. The roof top air conditioner must be mounted on a level plane from front to rear and side to side when the vehicle is parked on a level plane. Fig. 4 shows maximum allowable degrees that the unit can be mounted above or below level.
2. If the roof of the vehicle is sloped (not level) such that the roof top air conditioner cannot be mounted within the maximum allowable degree specifications, an exterior leveling shim will need to be added to make the unit level. A typical leveling shim is shown in Fig. 5.
3. Once the roof top air conditioner has been leveled, some additional shimming may be required above the interior ceiling assembly. The roof top air conditioner and the interior ceiling assembly must be square with each other before they are secured together.
4. After the mounting hole area is properly prepared, remove the carton and shipping pads from around the roof top air conditioner. Carefully lift the unit on top of the vehicle. Do not use the outer plastic shroud for lifting. Place the roof top air conditioner over the prepared mounting hole.
5. The front section of outdoor unit of air conditioner must be in the same direction as the vehicle, which is useful for reducing wind resistance.

Note: Try you best to put the unit on the horizontal surface for operation. The unit can only operate for a short time at the maximum sloping angle of 5° for preventing water leakage.

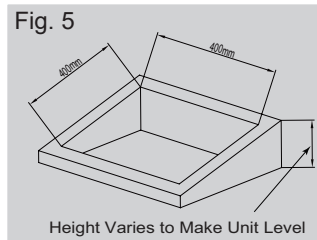
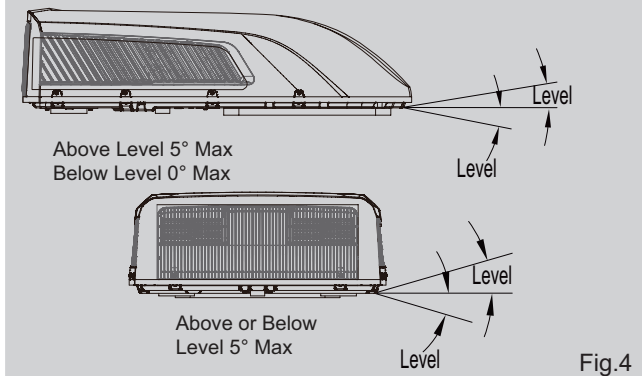

**NOTE: AIR CONDITIONER DIMENSIONS (ROOF OF UNIT)**

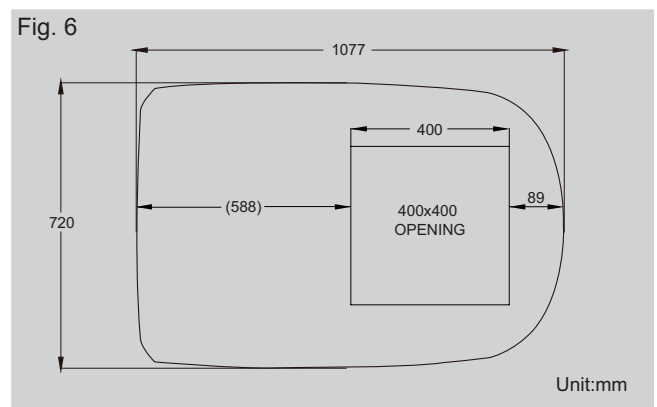



## 8.5 Mounting Outdoor Unit

1. Open the package and take out the outdoor unit.

1) When taking out the outdoor unit after unpacking, do not lift the air outlet grille at the back of outer case (see Fig.7).

2) Put the outdoor unit at the mounting plat of switchover opening.

1) Lift the outdoor unit. During the movement, it is strictly forbidden to hoist the plastic outer case of outer unit of the air conditioner.

2) Put it on the mounting plat of the prepared switchover opening to make the sealing strip of outdoor unit match with the groove on the surface of the mounting plat. Do not drag the outdoor unit. Otherwise, the seal may fall off.

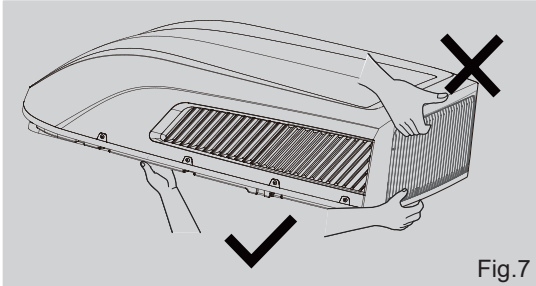

Fig.7

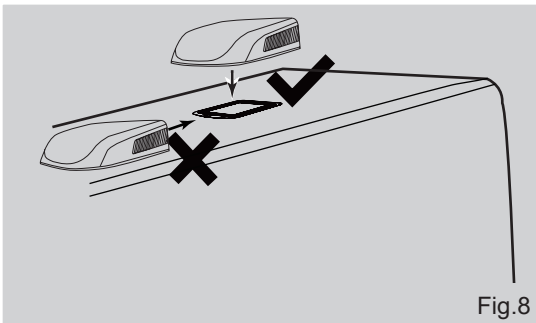

Fig.8

## 8.6 Installing The Ceiling Assembly

Make sure that you have properly matched the roof top air conditioner and interior ceiling assembly.

### Caution before tightening bolts:

1. The applicable thickness of vehicle roof ranges from 30mm~80mm.
2. Before tightening bolts, screw in the four bolts manually and prohibit screwing forcibly.
3. When screwing bolts, you can use automatic tool. Do not tighten one bolt completely and then tighten other bolts, in order to prevent sticking of screw thread.
4. The max torque for tightening ranges from 2.3Nm~2.5Nm.

The following step by step instructions must be performed in the following sequence to ensure proper installation.

1. Carefully take the ceiling assembly out of the carton.
2. Remove the ceiling grille from the ceiling assembly.
3. Then carry the outdoor unit to the vehicle's top and align with the openings on the vehicle's top. Use 2 sets of mounting plat assembly and 4 screw bolts to mount the outdoor unit (See Fig. 9).
4. You must start (thread) the mounting bolts by hand to avoid cross-threading. DO NOT START THE MOUNTING BOLTS WITH AN AIR GUN. The mounting bolts should be tightened, process is completed when the basepan gasket has been evenly compressed.
5. Before installing the air duct assembly of the indoor unit of recreational vehicle air conditioner, assemble the foam assembly according to the thickness of the vehicle's top. After simulated installation, use an appropriate amount of sponge and foam

assembly. Stick the sponge and foam assembly with double faced adhesive tape (prepared by user) (See Fig.10, Fig.11).

6. Install the foam assembly on the air duct assembly. Use 4 screw bolts to fix the air duct assembly onto the mounting plat.

After connecting the outdoor unit with indoor unit, check whether the foam assembly has come loose (See Fig. 9).

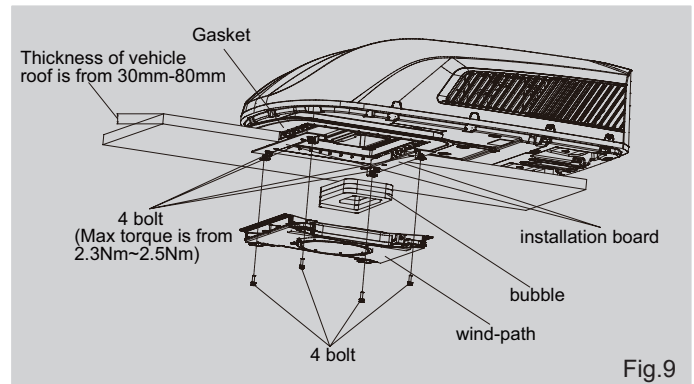

Fig.9

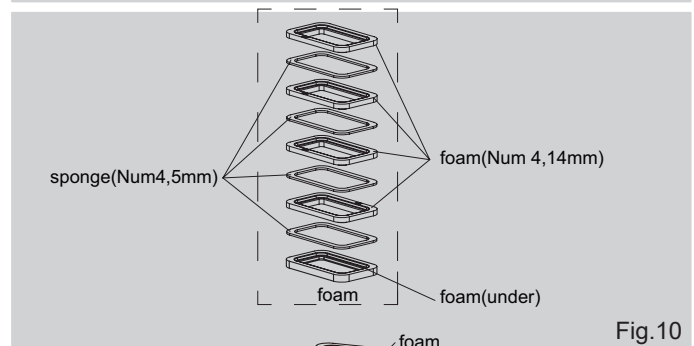

Fig.10



Fig.11

## 8.7 Electrical Wiring

### ⚠ WARNING

Make sure that all power supply to the unit is disconnected before performing any work on the unit to avoid the possibility of shock or injury and/or damage to the equipment. When the interior ceiling assembly frame is properly secured to the roof top air conditioner, the following electrical connections must be performed.

1. As shown in Fig.12, the outdoor unit has two sets of outgoing wires, which are power cord (high current) and the control signal wires respectively. The former one should be directly connected to the power supply terminal while the latter one should be connected to the control signal wire of the indoor unit.

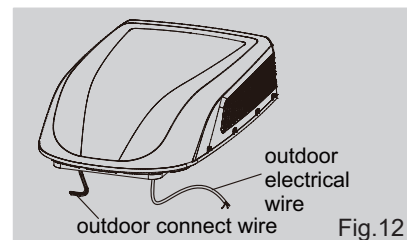
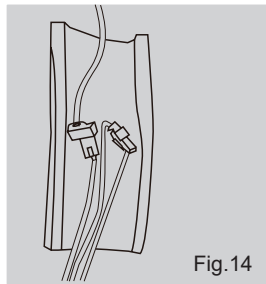
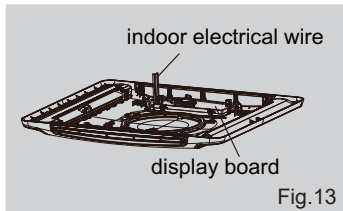

Fig.12

2. As shown in Fig.13, the indoor unit has one set of control signal wires, with 1 wiring terminals in total.
3. Connect the docking terminals of indoor unit and outdoor unit, see Fig.14.



4. Use protective sleeve to wrap the wiring terminal, stick the protective sleeve and then use cable tie to bundle them tightly.

Note:

1. The fixing position of cable must be at both ends of wiring terminal.

2. Before installing the front panel of indoor unit, put the thermal insulating jacket on top of the air duct.

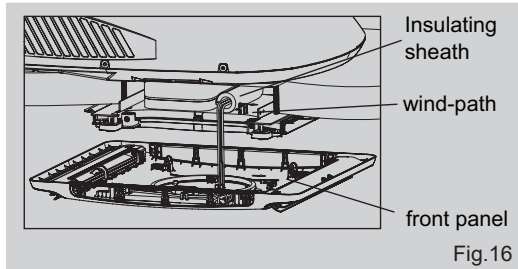
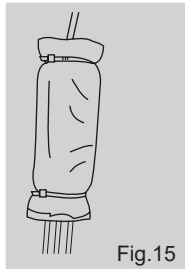

## 8.8 Completing The Installation

To complete the installation and system checkout requirements, the following steps must be performed.

1. Check the thermostat position. Make sure the thermostat is routed through the holding guide and is not touching any metal surface.

2. Secure the ceiling grille to the ceiling assembly wind-path with 4 screws. (see Fig.17).

3. Install the healthy filter and air intake grill. Press "PUSH" and lock with clasps.

4. Switch on the power supply and check the unit work or not.

5. Once the indoor unit is assembled, if the gap between the panel and the top of vehicle is not even, please ask the manufacturer to adjust it according to the assembly status.

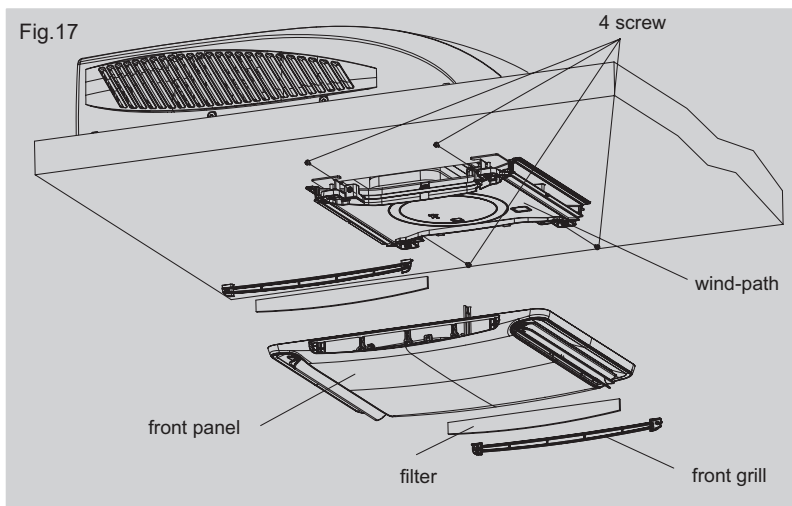

# 9. Maintenance

## 9.1 Error Code List

No.	Malfunction Name	Display Method of Indoor Unit (Error Code)	A/C Status	Possible Causes
1	Indoor ambient temperature sensor is open/shortcircuited	F1	When temperature sensor is open/shortcircuited, under cooling or heating mode, the unit will stop operation as it reaches the temperature point. Under fan mode, the unit operates according to original status.	<ol style="list-style-type: none"> <li>1. The wiring terminal between indoor ambient temperature sensor and controller is loosened or poorly contacted;</li> <li>2. There's short circuit due to trip-over of the parts on controller;</li> <li>3. Indoor ambient temperature sensor is damaged (Please check it by referring to the resistance table for temperature sensor)</li> <li>4. Main board is broken.</li> </ol>
2	Indoor evaporator temperature sensor is open/short-circuited	F2		<ol style="list-style-type: none"> <li>1. The wiring terminal between indoor evaporator temperature sensor and controller is loosened or poorly contacted;</li> <li>2. There's short circuit due to the trip-over of the parts on controller;</li> <li>3. Indoor evaporator temperature sensor is damaged (Please check it by referring to the resistance table for temperature sensor)</li> <li>4. Main board is broken.</li> </ol>
3	Outdoor ambient temperature sensor is open/shortcircuited	F3		<ol style="list-style-type: none"> <li>1. The wiring terminal between outdoor ambient temperature sensor and controller is loosened or poorly contacted;</li> <li>2. There's short circuit due to trip-over of the parts on controller;</li> <li>3. Outdoor ambient temperature sensor is damaged (Please check it by referring to the resistance table for temperature sensor)</li> <li>4. Main board is broken.</li> </ol>
4	Outdoor condenser temperature sensor is open/short-circuited	F4		<ol style="list-style-type: none"> <li>1. The wiring terminal between outdoor condenser temperature sensor and controller is loosened or poorly contacted;</li> <li>2. There's short circuit due to the trip-over of the parts on controller;</li> <li>3. Outdoor condenser temperature sensor is damaged (Please check it by referring to the resistance table for temperature sensor)</li> <li>4. Main board is broken.</li> </ol>
5	Insufficient fluorine protection	F0	Indoor fan runs according to set fan and other loads will stop.	<ol style="list-style-type: none"> <li>1. Heat exchangers are too dirty or the air inlet/outlet is blocked.</li> <li>2. Compressor doesn't work normally. Strange noise or leakage occurs. Temperature of the shell is too high.</li> <li>3. System is blocked inside (dirt block, ice block, oil block, Y-valve not fully open).</li> <li>4. The refrigerant is leaking.</li> </ol>
6	WIFI communication malfunction	JF	Loads operate normally, while the unit can't be normally controlled by APP.	<ol style="list-style-type: none"> <li>1. Main board of outdoor unit is damaged;</li> <li>2. Detection board is damaged;</li> <li>3. The connection between outdoor unit and detection board is not good;</li> </ol>
7	The power supply voltage is lower than 184V	PL	When the power supply voltage is less than 184V, all loads stop operation except LED indicator.	<ol style="list-style-type: none"> <li>1. The power supply voltage is lower than 184V;</li> <li>2. The main board of outdoor unit is damaged.</li> </ol>
8	Overload protection for compressor	H3	Indoor fan runs according to set fan and other loads will stop	<ol style="list-style-type: none"> <li>1. Heat exchangers are too dirty or the air inlet/outlet is blocked.</li> <li>2. Fan motor doesn't work at a normal fan speed; fan speed is too low or the fan doesn't run.</li> <li>3. Compressor doesn't work normally. Strange noise or leakage occurs. Temperature of the shell is too high.</li> <li>4. System is blocked inside (dirt block, ice block, oil block, Y-valve not fully open).</li> <li>5. The refrigerant is leaking and cause overheating protection to compressor.</li> </ol>
9	Overload malfunction	E8	During cooling or drying operation, indoor fan operates and other loads will stop.	<ol style="list-style-type: none"> <li>1. The environment is formidable.</li> <li>2. Heat exchangers are too dirty or the air inlet/outlet is blocked.</li> <li>3. Fan motor doesn't work at a normal fan speed; fan speed is too low or the fan doesn't run.</li> <li>4. Compressor doesn't work normally. Strange noise or leakage occurs. Temperature of the shell is too high.</li> <li>5. System is blocked inside (dirt block, ice block, oil block, Y-valve not fully open).</li> <li>6. Temperature sensor of main board can't detect correctly.</li> </ol>
10	Communication error of indoor and outdoor unit	E6	Cool, fan and dry: compressor and outdoor unit stops operation, while the indoor fan operates. Heating: all loads stop operation.	<ol style="list-style-type: none"> <li>1. The connection wire of indoor and outdoor unit is poor;</li> <li>2. Wiring inside the unit is abnormal and damaged;</li> <li>3. Communication circuit of control panel of indoor or outdoor unit is abnormal;</li> </ol>

## 9.2 Procedure of Troubleshooting

### 1. Malfunction of Temperature Sensor F1~F4

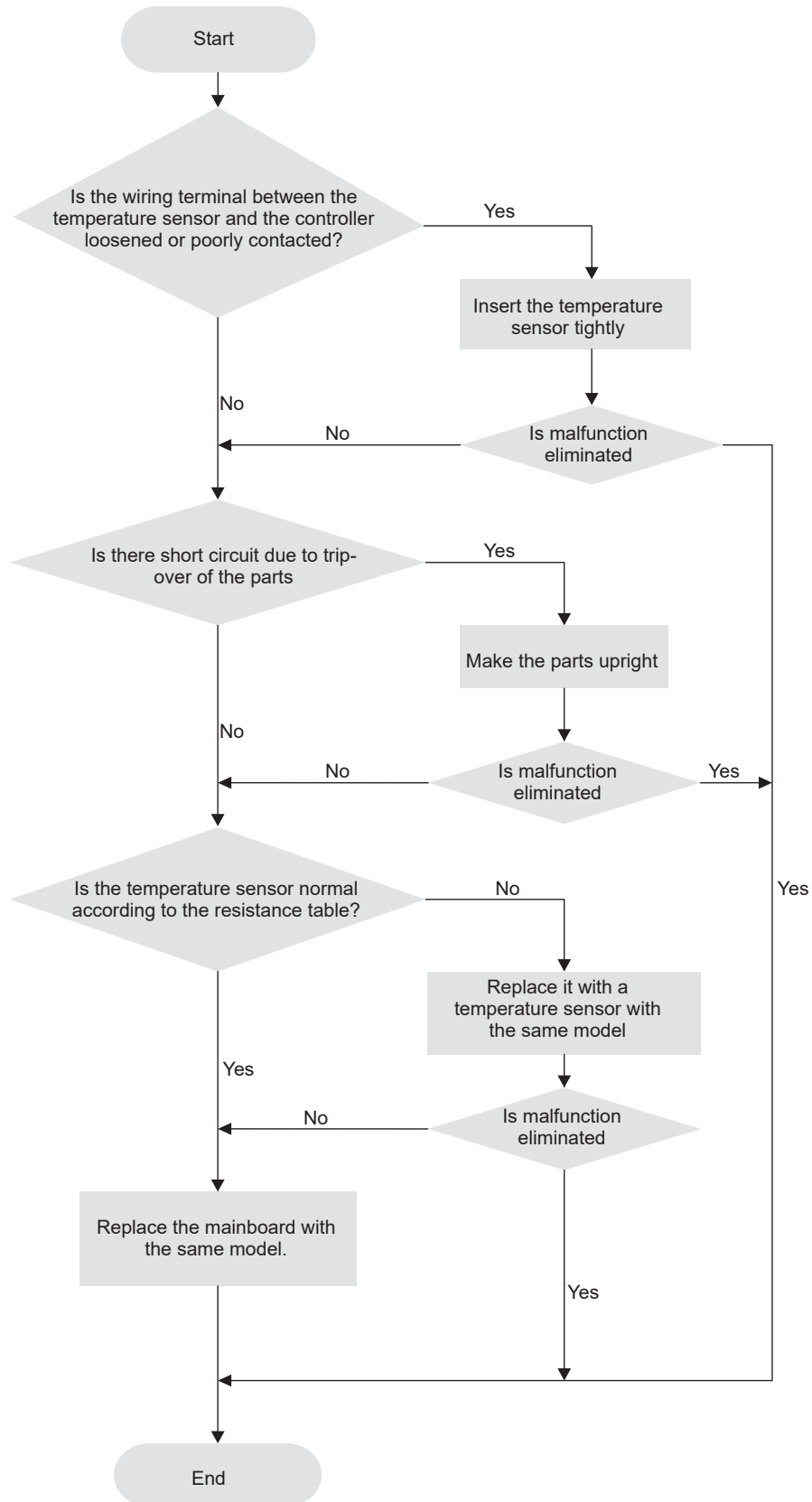

## 2. Malfunction of detecting plate(WIFI) JF

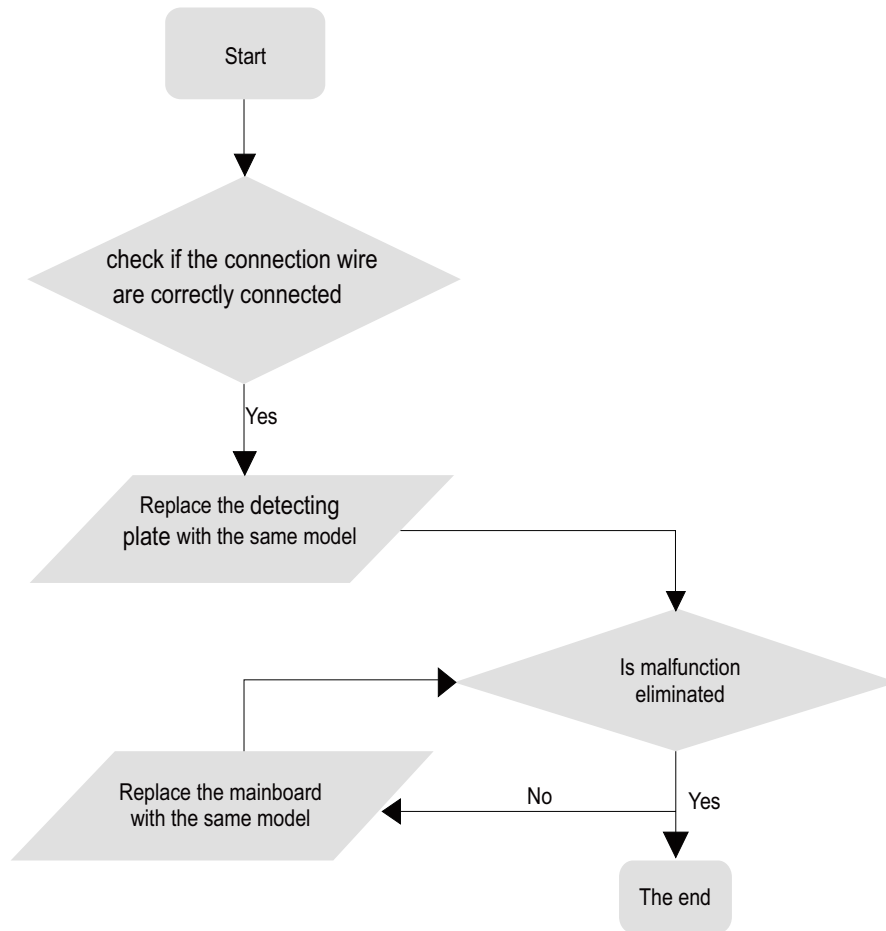

### 3. Overload malfunction E8

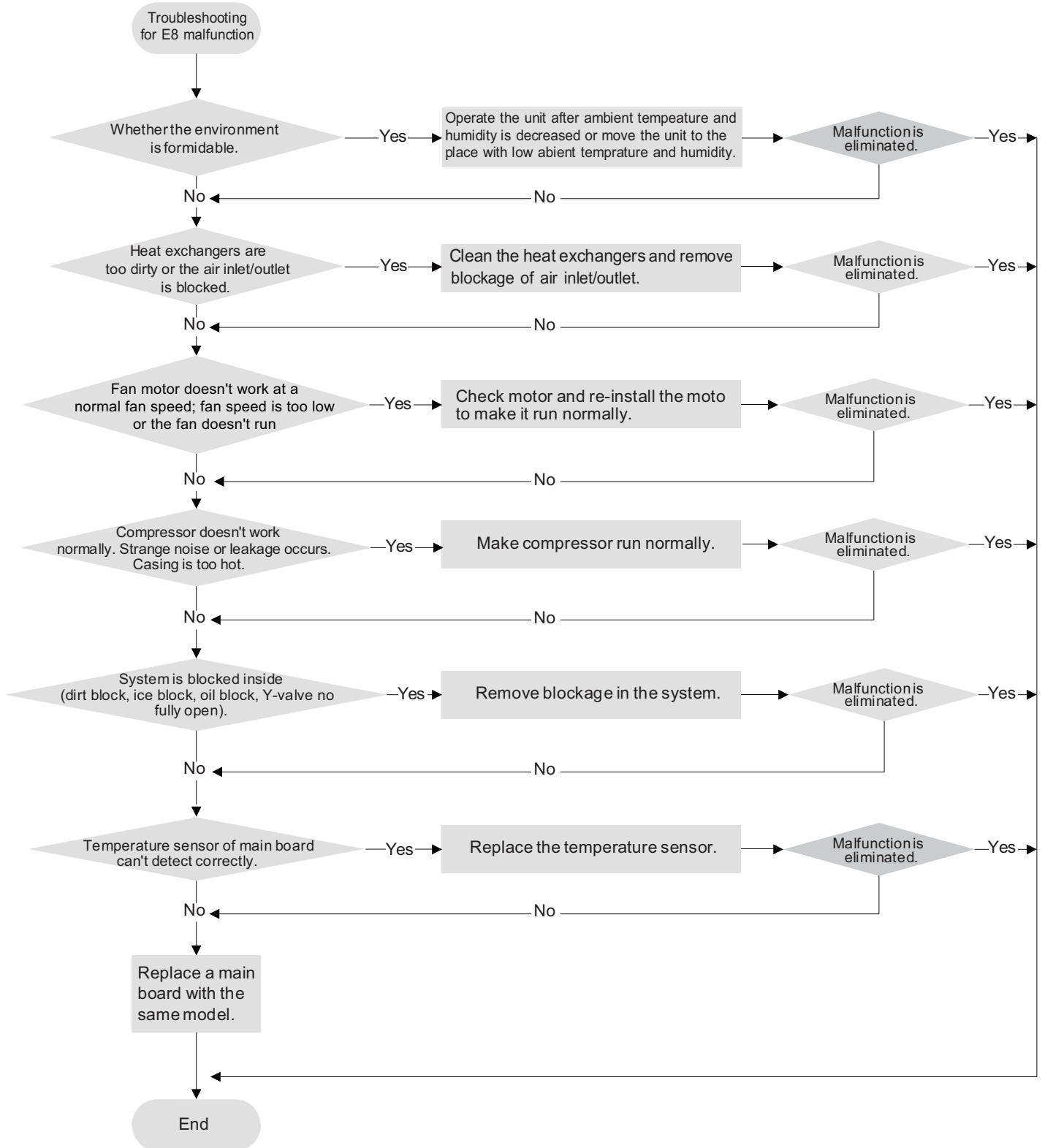

#### 4. Malfunction of Insufficient fluorine protection F0

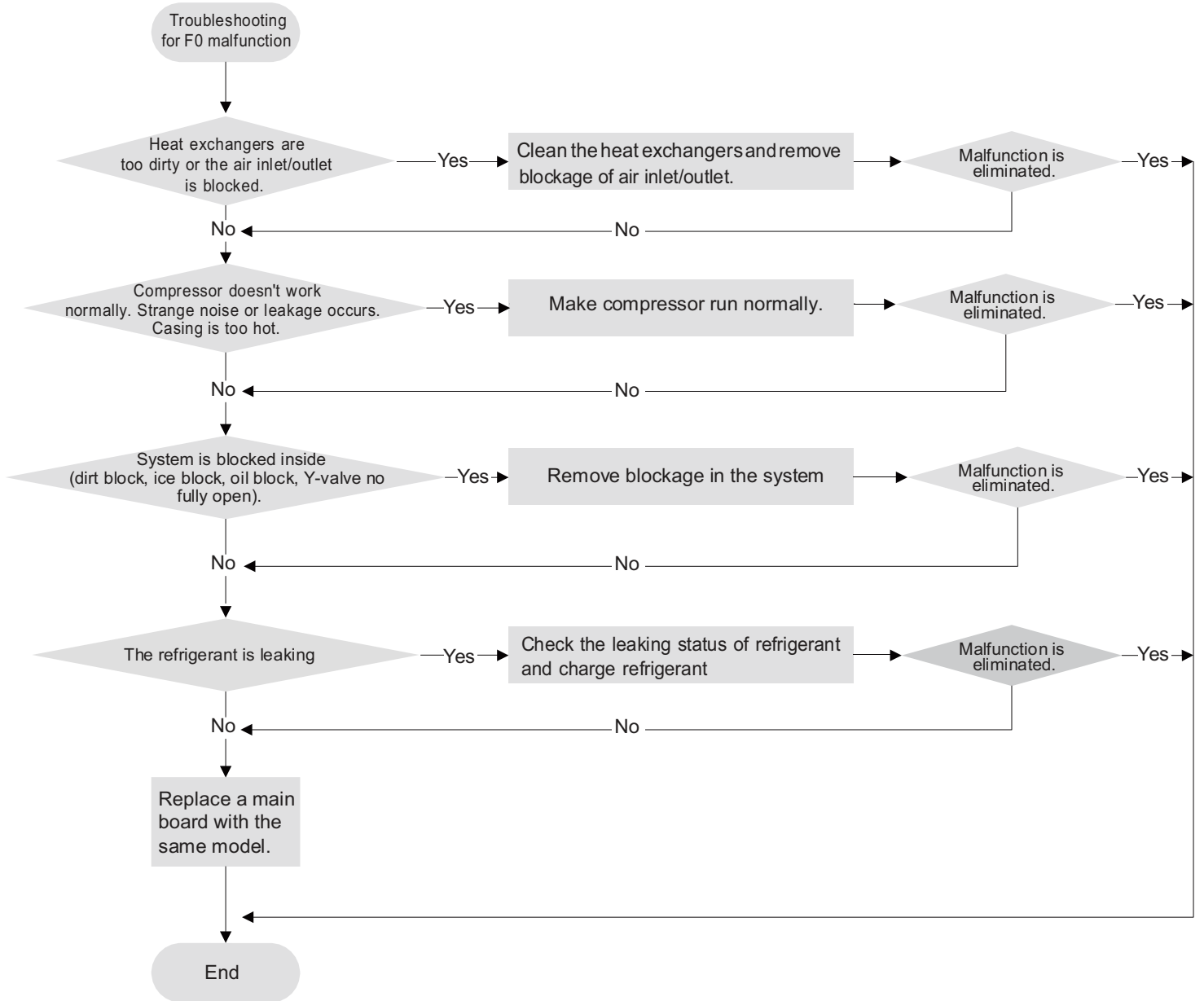

### 5. Overload malfunction H3

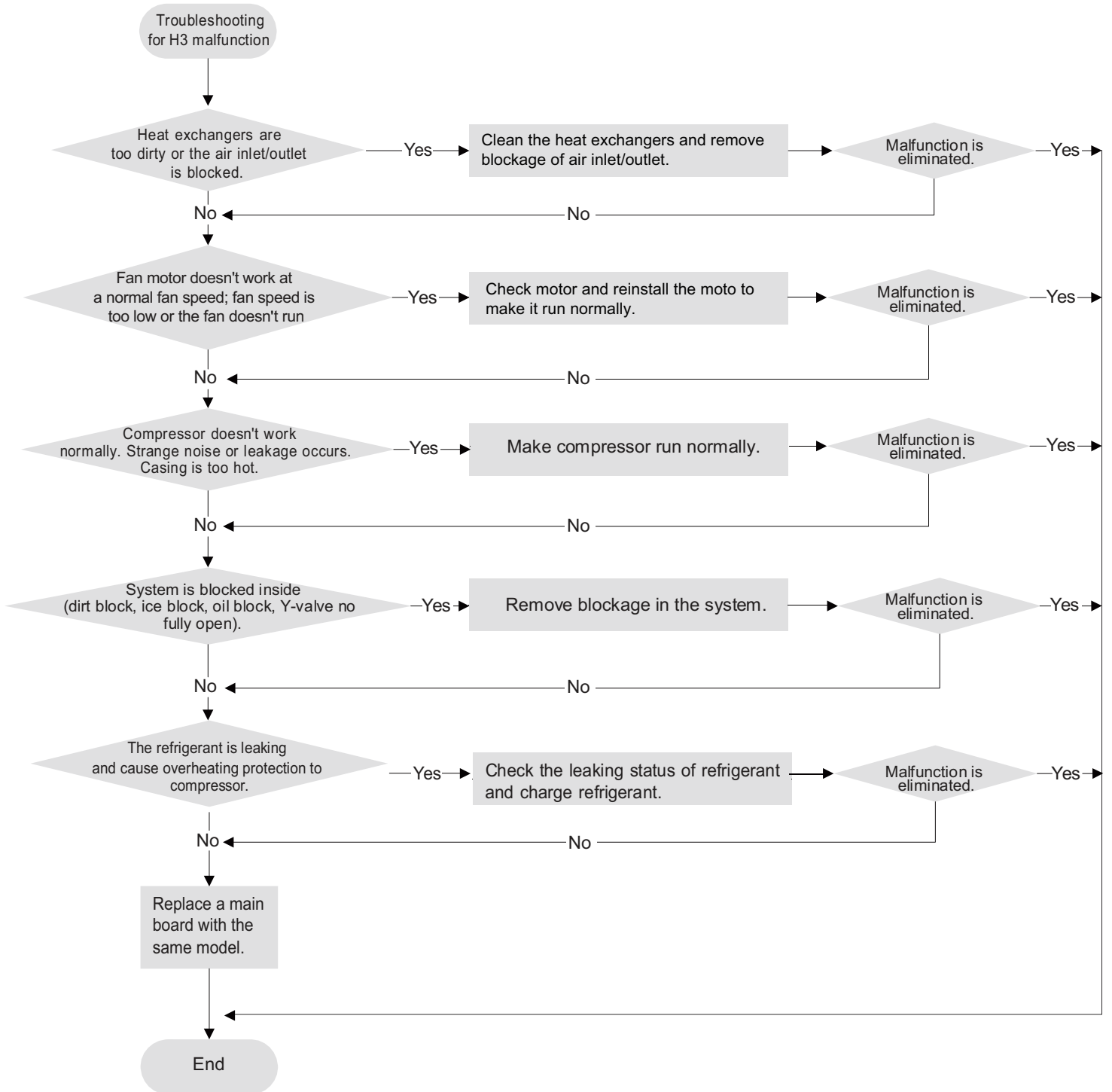



## 6. Overload malfunction PL

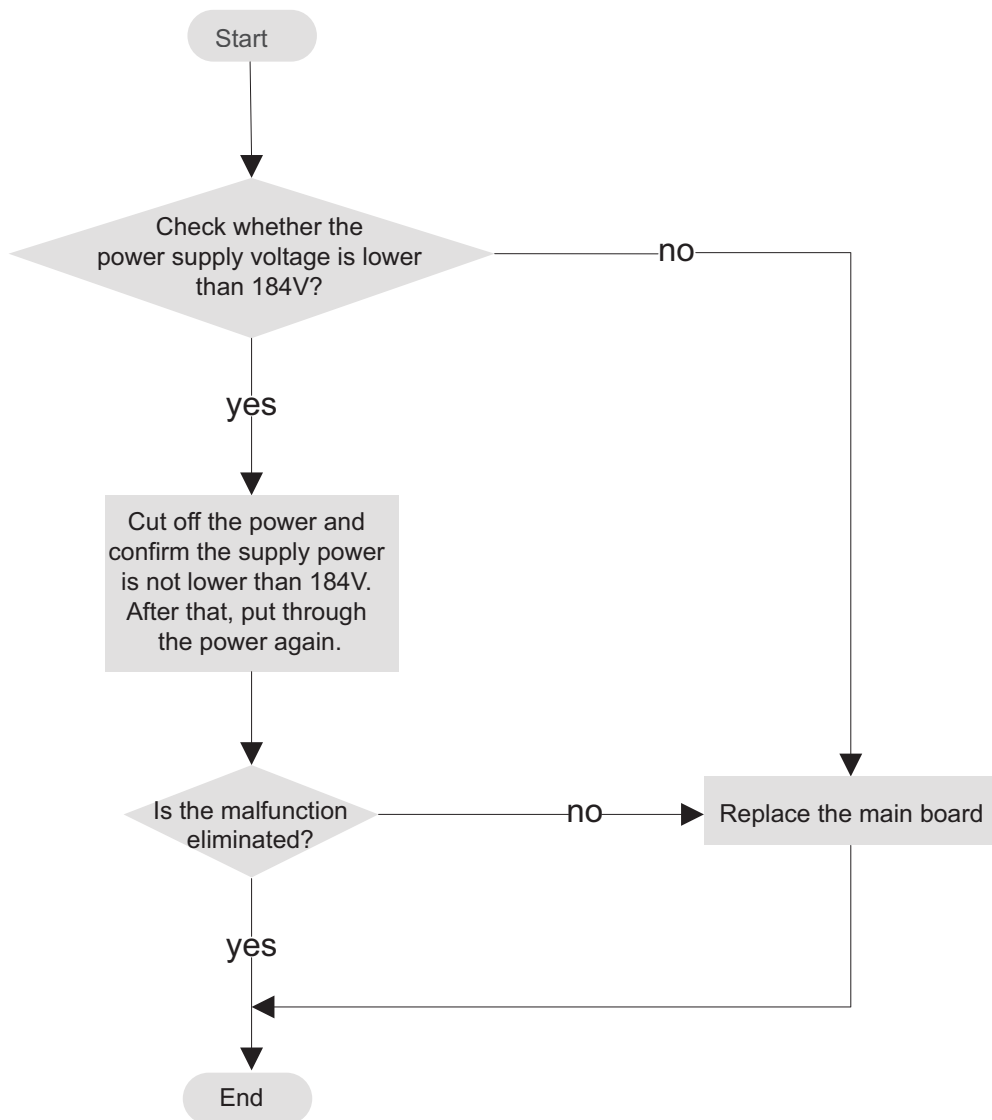

## 7. Communication malfunction E6

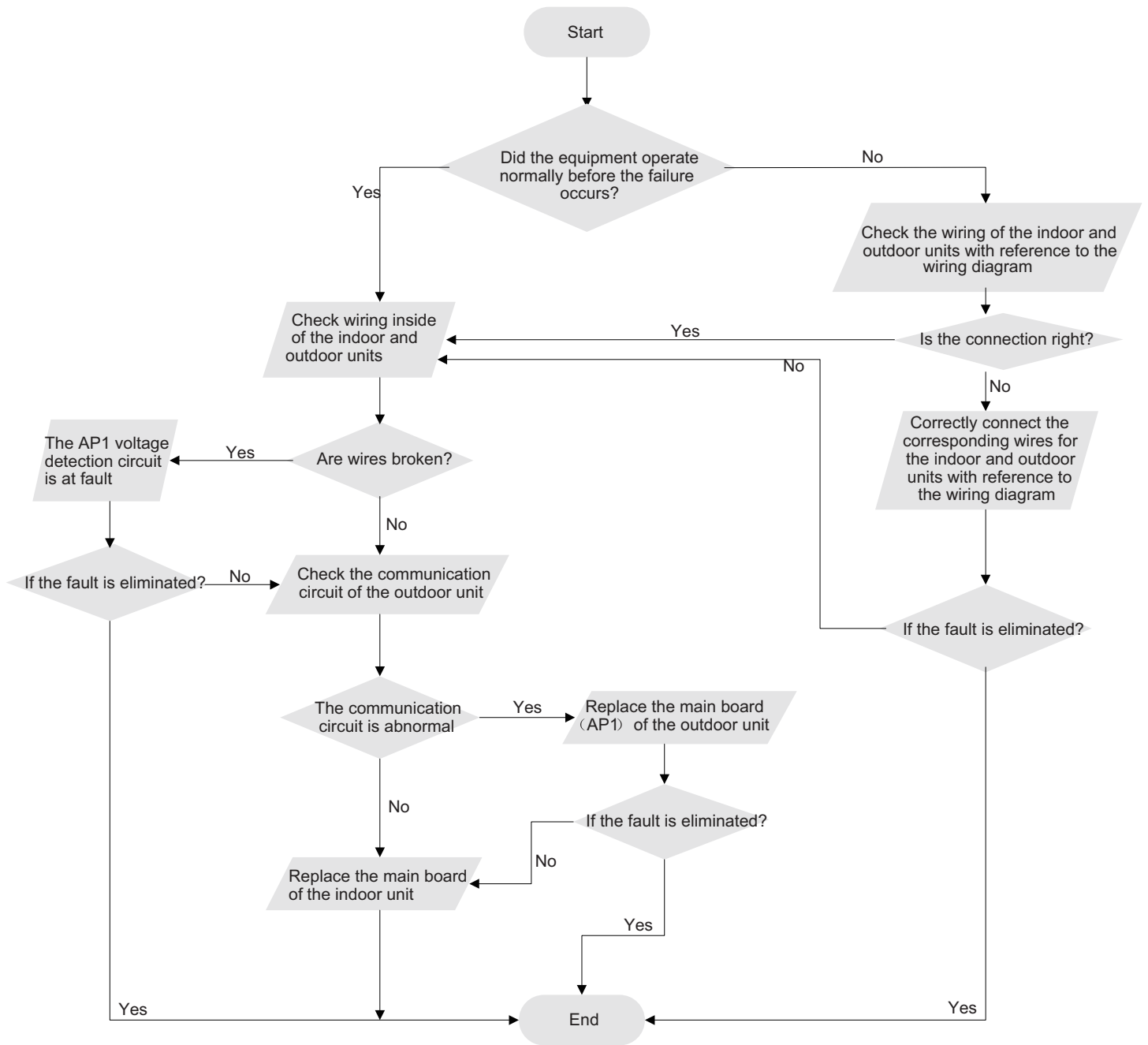

# 10. Exploded View and Parts List

## 10.1 Indoor Unit

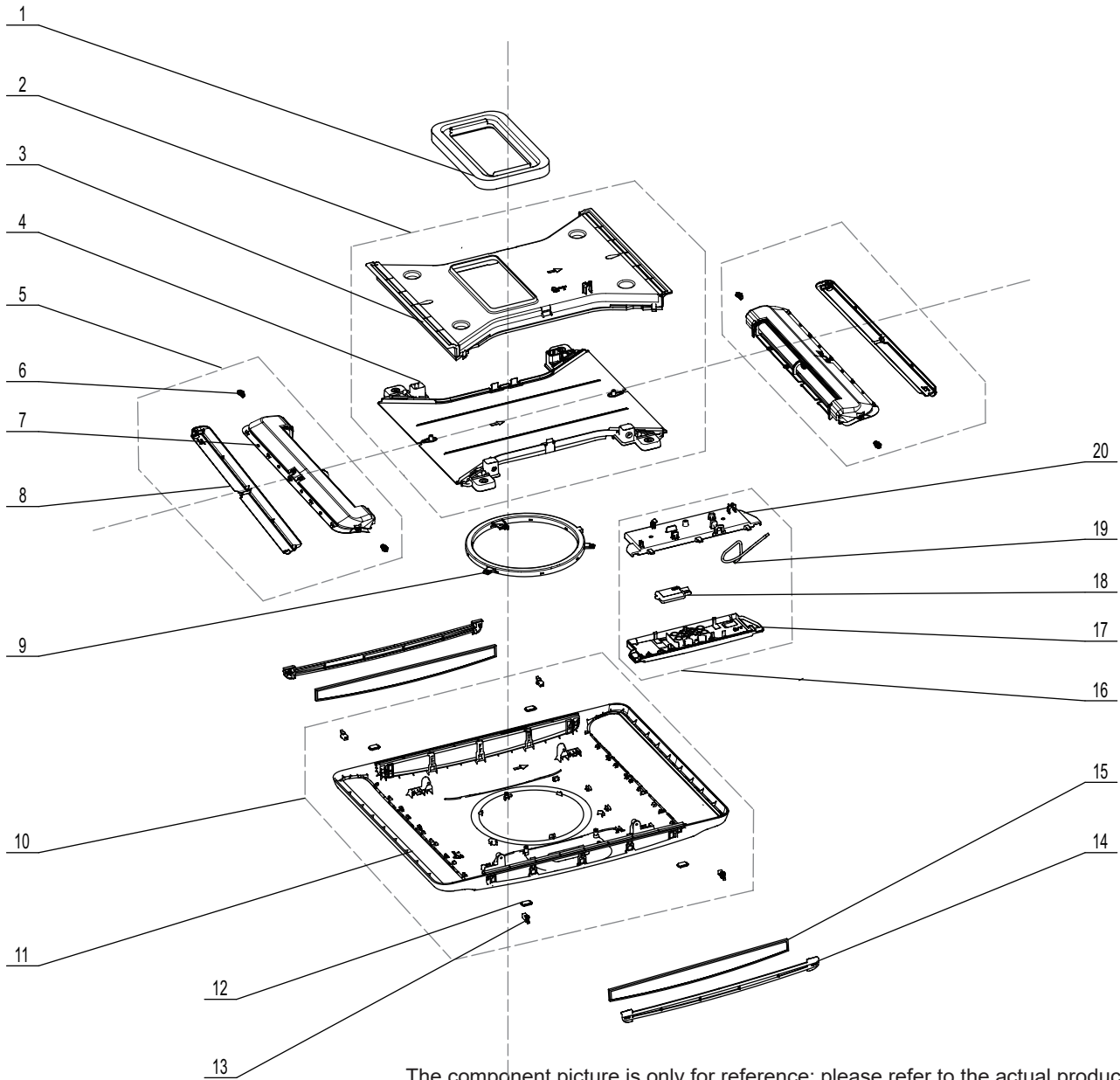

The component picture is only for reference; please refer to the actual product.

NO.	Description	Qty
1	Foam	1
2	Air Duct Sub-assy	1
3	Air Outlet Mid-panel	1
4	Base Plate	1
5	Air Outlet Frame Sub-assy	2
6	Shaft of Guide Louver	1
7	Air Outlet Frame	1
8	Guide Louver	1
9	Display Module	1
10	Front Panel Sub-Assy	1

NO.	Description	Qty
11	Front Panel	1
12	Magnet Sub-assy	4
13	Latch	4
14	Front Grill	2
15	Healthy Filter	2
16	Display Board	1
17	Display Box	1
18	Detecting Plate	1
19	Temperature Sensor	1
20	Display Box Cover	1

Some models may not contain some parts, please refer to the actual product.

## 10.2 Outdoor Unit

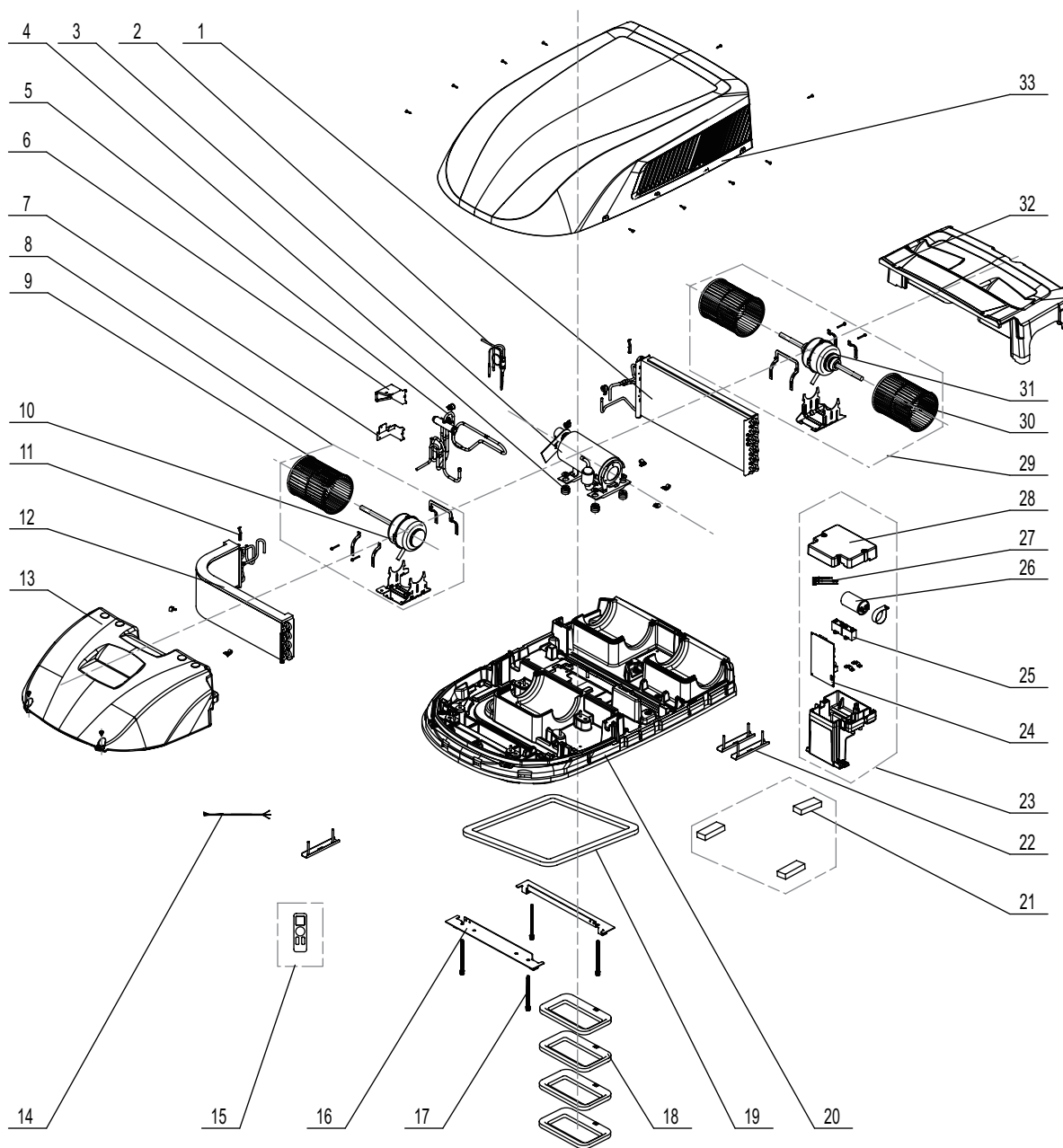

The component is only for reference; please refer to the actual product

No.	Description	Qty
1	Condenser Assy	1
2	Capillary Sub-assy	1
3	Compressor and Fittings	1
4	Compressor Gasket	4
5	4-Way Valve Assy	1
6	Water baffle (4-way valve)	1
7	Water baffle (fixing pipe)	1
2	Centrifugal fan (inside)	1
9	Centrifugal fan blade	1
10	Fan Motor	1
11	Sensor Insert	2
12	Evaporator Assy	1
13	Foam (inner side)	1
14	Connecting Cable	1
15	Remote Controller	1
16	mounting plat Sub-Assy	2
17	Bolt	4

No.	Description	Qty
18	Foam	4
19	Sponge (sealing strip)	1
20	Chassis Assy	1
21	Sponge	3
22	Motor base Assy	3
23	Electric Box Assy	1
24	Main Board	1
25	Capacitor CBB61S	2
26	Capacitor CBB65	1
27	Temperature Sensor	1
28	Electric Box Cover	1
29	Centrifugal fan (outside)	1
30	Centrifugal fan blade	2
31	Fan Motor	1
32	Foam (outside)	1
33	Cabinet	1

Some models may not contain some parts,  
please refer to the actual product.

# 11. Removal Procedure

## 11.1 Removal Procedure of Indoor Unit

Step	Procedure	Procedure
<b>1. Remove air-in grille and the filter</b>	Press both ends of air-outlet grille to unlock the door switch and then remove the air-in grille and the filter.	
<b>2. Remove front panel sub-assy</b>	Loose 4 screws at both ends and then remove the panel sub-assy downwards.	
<b>3. Remove air duct sub-assy</b>	Loose 4 bolts as shown in the figure and then remove the air duct sub-assy downwards.	 <p data-bbox="1166 1873 1221 1904">Bolts</p>

Step	Procedure
<p><b>4. Remove base plate and the middle air-outlet panel</b></p>	<p>Loose 2 screws at both ends; loose 7 clasps at both sides and then separate the base plate and the middle air-outlet panel.</p> 
<p><b>5. Remove detecting board</b></p>	<p>Loose 1 screw on the top; remove the detecting board.</p> 
<p><b>6. Remove display board</b></p>	<p>Loose 2 screws as shown in the figure and the remove the display board.</p> 

Step	Procedure
<p><b>7. Remove display module</b></p>	<p>Loose 1 screw as shown in the figure, and rotate the display module in clockwise direction to remove it.</p>  <p>Screw</p>
<p><b>8. Remove air-outlet frame sub-assy</b></p>	<p>Press inwards to press out the 5 clasps on the outside of the air-outlet frame sub-assy, so that the clasps out of the panel and pull down, so that the inside 4 limit clasps out can remove the air-outlet frame sub-assy. Remove another air-outlet frame sub-assy in the same way.</p>  <p>clasp</p> <p>clasp</p>
<p><b>9. Remove guide louver and shaft of guide louver</b></p>	<p>Loose the middle clasp, remove the horizontal louver outwards and then remove the shaft of horizontal louver at both ends.</p>  <p>clasp</p>



## 11.2 Removal Procedure of Outdoor Unit

 **Caution: discharge the refrigerant completely before removal.**

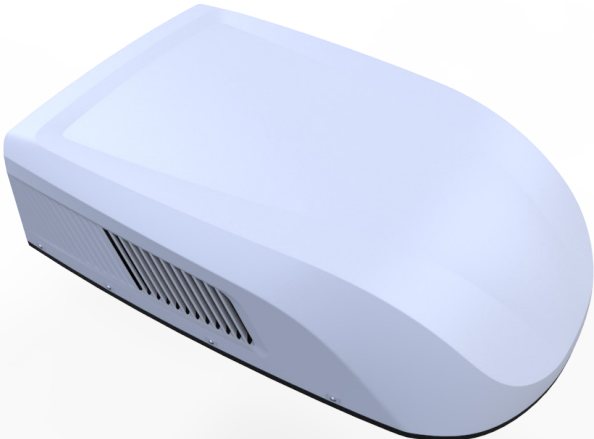
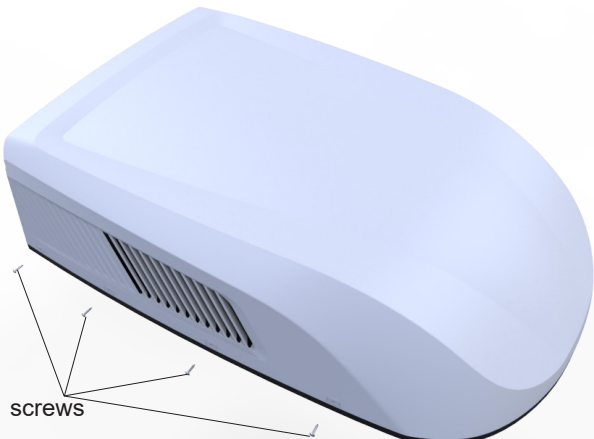
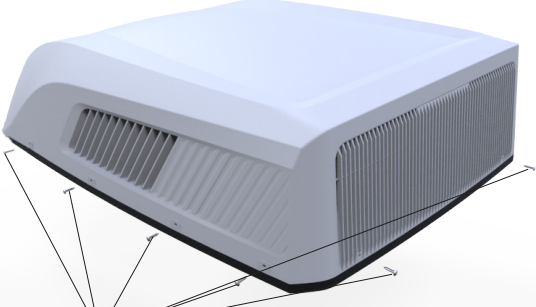
Step	Procedure
1. Outdoor unit diagram	
2.Remove outer case	<p data-bbox="185 1083 773 1137">Remove screws fixing outer case. Lift up to remove the outer case.</p>  <p data-bbox="857 1297 932 1319">screws</p>  <p data-bbox="922 1917 997 1939">screws</p>

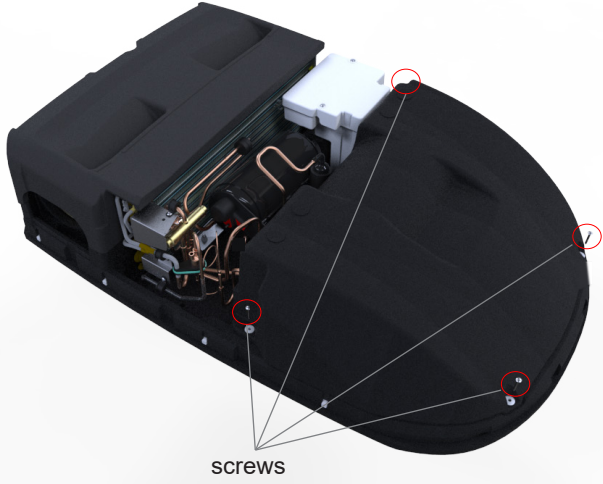
Step	Procedure
<p><b>3.Remove foam(inner side)</b></p> <p>Remove screws fixing the foam(inner side) and then remove the foam(inner side).</p>	 <p>screws</p>
<p><b>4.Remove foam(outside)</b></p> <p>Remove screws fixing the foam(outside) and then remove the foam(outside).</p>	 <p>screw</p>
<p><b>5.Remove Electric Box Cover</b></p> <p>Remove screws fixing the electric box cover and then remove the electric box cover.</p>	 <p>Electric box cover</p> <p>screws</p>

Step	Procedure
------	-----------

**7.Remove electric box assy**

Lift the mainboard, disconnect each wiring terminal on the mainboard; Remove screws fixing the electric box assy, remove the ground screw on the condenser and then lift the electric box assy to remove it.

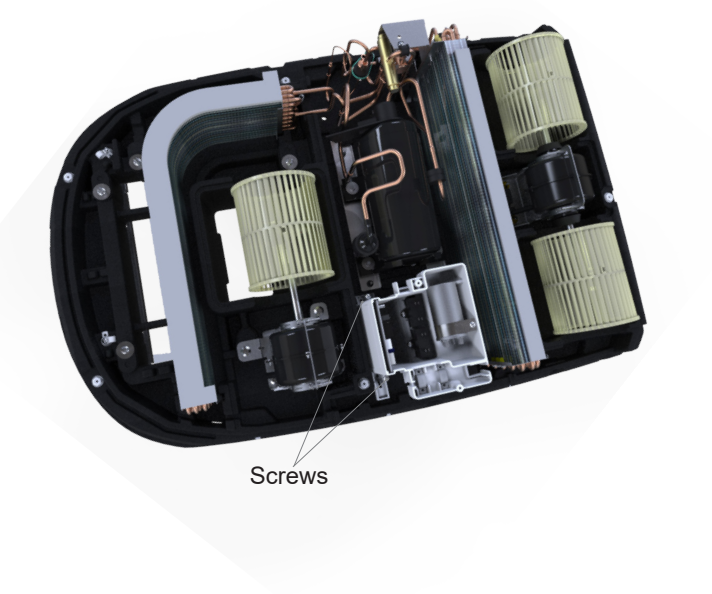
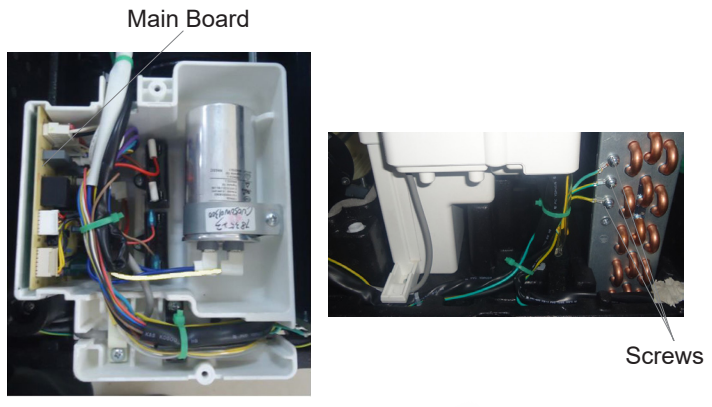

**8.Remove water baffle**

Remove screw fixing the water baffle (4-way valve); remove screw fixing the tube clip, then remove the water baffle (4-way valve).

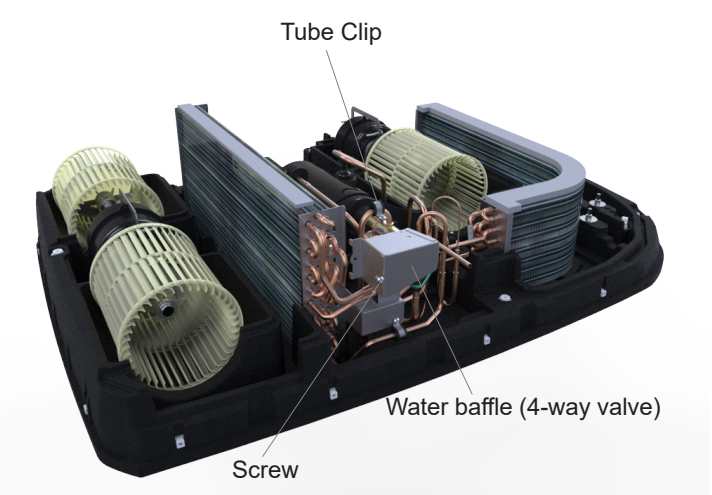

Step	Procedure
------	-----------

Remove screw fixing the water baffle (fixing pipe); remove screws fixing the tube clip, then remove the water baffle(fixing pipe).

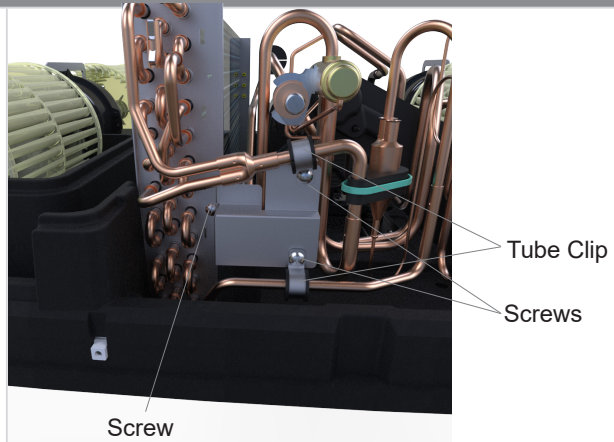

### 9.Remove Magnet Coil

Remove bolt fixing the magnet coil and then remove the magnet coil.

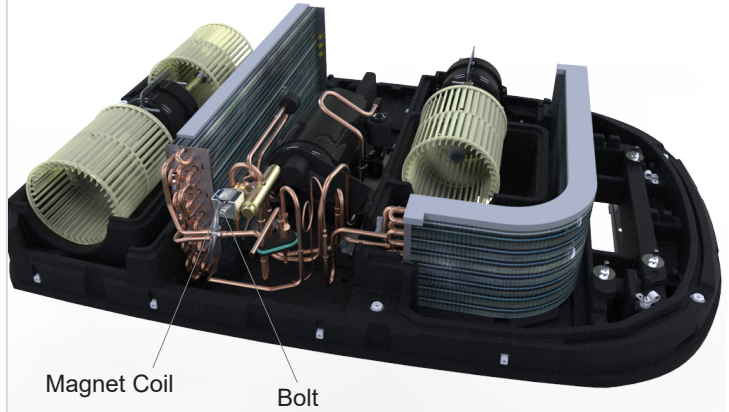

### 10.Remove Capillary Sub-assy

Cut the cable tie and remove the fixed block of tube. Unsolder the welding joint between the capillary sub-assy and then remove the capillary sub-assy.

Note:

- 1.Before unsoldering the welding joint, please make sure the refrigerant is discharged completely.
- 2.Before unsoldering the welding joint of capillary, wrap the capillary with a wet cloth completely to avoid damage to the capillary caused by high temperature. Seal the discharge pipe port and suction pipe port of compressor with rubber plug or rubber paper to avoid impurities getting into the pipe.

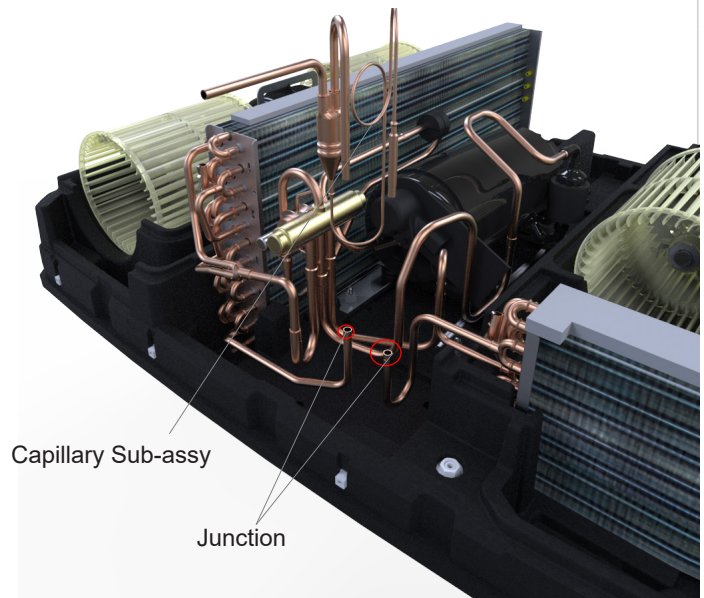

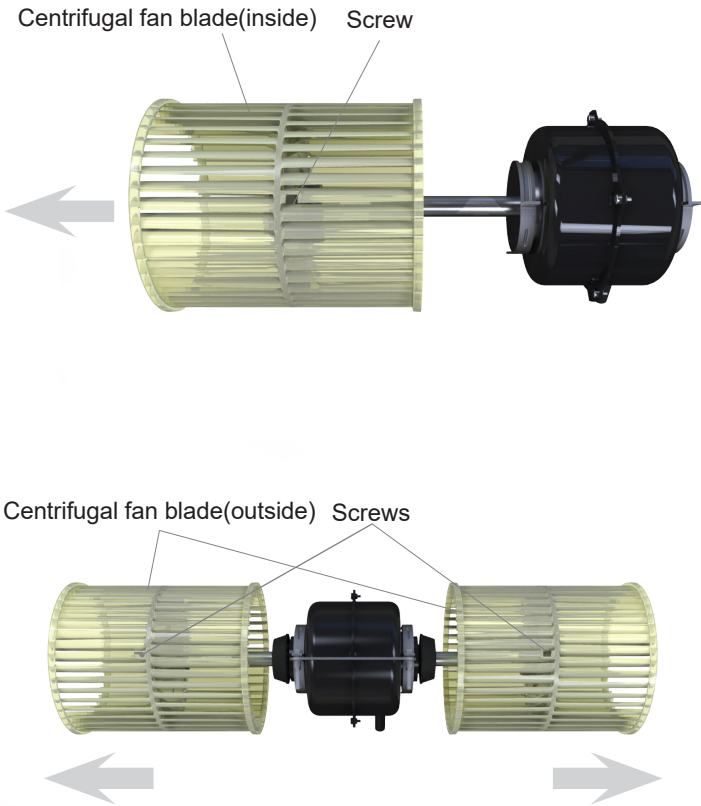
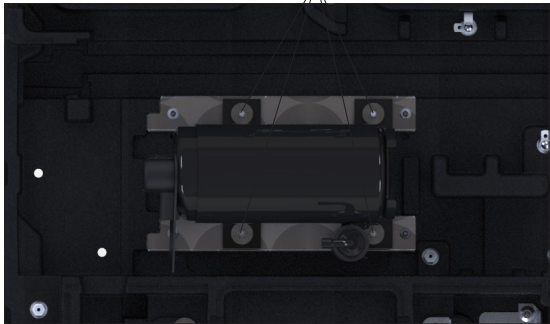

Step	Procedure
<p><b>10.Remove 4-way valve assy</b></p> <p>Unsolder the welding joint connecting the 4-way valve assy and then unsolder the 4-way valve assy.  Note:  1.Before unsoldering the welding joint, please make sure the refrigerant is discharged completely.  2.Before unsoldering the welding joint connecting the 4-way valve, wrap the 4-way valve assy with a wet cloth completely to avoid damage to the valve caused by high temperature.</p>	 <p>Welding joint</p>
<p><b>11.Remove condenser assy, evaporator assy</b></p> <p>Lift up, remove the condenserassy and evaporator assy.</p>	 <p>Condenser assy</p> <p>Evaporator assy</p>
<p><b>12.Remove Fan Motor And Centrifugal Fan Blade</b></p> <p>Remove Screws fixing the bar clasp, remove the fan motor and centrifugal fan blade.</p>	 <p>Fan Motor(outside)</p> <p>Rivet Jiont Nut</p> <p>Bar Clasp</p> <p>Screws</p>

Step	Procedure
<p><b>13.Remove Centrifugal Fan Blade</b></p> <p>Remove screws fixing the centrifugal fan; Pull out in the direction of the arrow, remove the centrifugal fan.</p>	 <p>Centrifugal fan blade(inside) Screw</p> <p>Centrifugal fan blade(outside) Screws</p>
<p><b>14.Remove Compressor</b></p> <p>Remove nuts with washer fixing the compressor; remove the compressor.</p>	 <p>Nuts with Washer</p>

# Appendix

## Appendix 1: Reference Sheet of Celsius and Fahrenheit

Conversion formula for Fahrenheit degree and Celsius degree:  $T_f = T_c \times 1.8 + 32$

### Set temperature

Fahrenheit display temperature (°F)	Fahrenheit (°F)	Celsius (°C)	Fahrenheit display temperature (°F)	Fahrenheit (°F)	Celsius (°C)	Fahrenheit display temperature (°F)	Fahrenheit (°F)	Celsius (°C)
61	60.8	16	69/70	69.8	21	78/79	78.8	26
62/63	62.6	17	71/72	71.6	22	80/81	80.6	27
64/65	64.4	18	73/74	73.4	23	82/83	82.4	28
66/67	66.2	19	75/76	75.2	24	84/85	84.2	29
68	68	20	77	77	25	86	86	30

### Ambient temperature

Fahrenheit display temperature (°F)	Fahrenheit (°F)	Celsius (°C)	Fahrenheit display temperature (°F)	Fahrenheit (°F)	Celsius (°C)	Fahrenheit display temperature (°F)	Fahrenheit (°F)	Celsius (°C)
32/33	32	0	55/56	55.4	13	79/80	78.8	26
34/35	33.8	1	57/58	57.2	14	81	80.6	27
36	35.6	2	59/60	59	15	82/83	82.4	28
37/38	37.4	3	61/62	60.8	16	84/85	84.2	29
39/40	39.2	4	63	62.6	17	86/87	86	30
41/42	41	5	64/65	64.4	18	88/89	87.8	31
43/44	42.8	6	66/67	66.2	19	90	89.6	32
45	44.6	7	68/69	68	20	91/92	91.4	33
46/47	46.4	8	70/71	69.8	21	93/94	93.2	34
48/49	48.2	9	72	71.6	22	95/96	95	35
50/51	50	10	73/74	73.4	23	97/98	96.8	36
52/53	51.8	11	75/76	75.2	24	99	98.6	37
54	53.6	12	77/78	77	25			

## Appendix 2: List of Resistance for Temperature Sensor

### Resistance Table of Ambient Temperature Sensor for Indoor and Outdoor Units(15K)

Temp(°C)	Resistance(kΩ)
-19	138.10
-18	128.60
-16	115.00
-14	102.90
-12	92.22
-10	82.75
-8	74.35
-6	66.88
-4	60.23
-2	54.31

Temp(°C)	Resistance(kΩ)
0	49.02
2	44.31
4	40.09
6	36.32
8	32.94
10	29.90
12	27.18
14	24.73
16	22.53
18	20.54

Temp(°C)	Resistance(kΩ)
20	18.75
22	17.14
24	15.68
26	14.36
28	13.16
30	12.07
32	11.09
34	10.20
36	9.38
38	8.64

Temp(°C)	Resistance(kΩ)
40	7.97
42	7.35
44	6.79
46	6.28
48	5.81
50	5.38
52	4.99
54	4.63
56	4.29
58	3.99

### Resistance Table of Tube Temperature Sensors for Indoor and Outdoor (20K)

Temp(°C)	Resistance(kΩ)
-19	181.40
-15	145.00
-10	110.30
-5	84.61
0	65.37
5	50.87
10	39.87
15	31.47

Temp(°C)	Resistance(kΩ)
20	25.01
25	20.00
30	16.10
35	13.04
40	10.62
45	8.71
50	7.17
55	5.94

Temp(°C)	Resistance(kΩ)
60	4.95
65	4.14
70	3.48
75	2.94
80	2.50
85	2.13
90	1.82
95	1.56

Temp(°C)	Resistance(kΩ)
100	1.35
105	1.16
110	1.01
115	0.88
120	0.77
125	0.67
130	0.59
135	0.52



## NOTE CONCERNING PROTECTION OF ENVIRONMENT

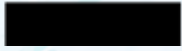

This product must not be disposed of via normal household waste after its service life, but must be taken to a collection station for the recycling of electrical and electronic devices. The symbol on the product, the operating instructions or the packaging indicate such disposal procedures. The materials are recyclable in accordance with their respective symbols. By means of re-use, material recycling or any other form of recycling old appliances you are making an important contribution to the protection of our environment. Please ask your local council where your nearest disposal station is located.

## INFORMATION CONCERNING USED REFRIGERANT MEDIUM

This unit is containing fluorinated gases included in the Kyoto protocol.  
The maintenance and the liquidation must be carried out by qualified personnel.

Type of refrigerant: R32

The quantity of the refrigerant: Please see the unit label.

The value GWP: 675 (1 kg R32 = 0,675 t CO<sub>2</sub> eq)

GWP = Global Warming Potential



Appliance filled with flammable gas R32.

In case of quality problem or other please contact your local supplier or authorized service center.

**Emergency number: 112**

## PRODUCER

SINCLAIR CORPORATION Ltd.

1-4 Argyll St.

London W1F 7LD

Great Britain

[www.sinclair-world.com](http://www.sinclair-world.com)

This product was manufactured in China (Made in China).

## REPRESENTATIVE

SINCLAIR Global Group s.r.o.

Purkynova 45

612 00 Brno

Czech Republic

## TECHNICAL SUPPORT

SINCLAIR Global Group s.r.o.

Purkynova 45

612 00 Brno

Czech Republic

Tel.: +420 800 100 285 | Fax: +420 541 590 124

[www.sinclair-solutions.com](http://www.sinclair-solutions.com) | [info@sinclair-solutions.com](mailto:info@sinclair-solutions.com)







