

Data Sheet

# Motor and Servo operated valves Type **ICM-HMMV** and **ICM-HMMR**

Motor controlled ICM in 2 variants HMMR and HMMV, which besides very accurate regulation also handles and controls direct expansion



The ICM motor variant is an electronic controlled valve driven by the actuator type ICAD. The ICM valve is designed to control pressure or temperature in all locations of a refrigeration system and additionally the valve is designed to control an expansion process (expansion over the valve).

The opening and closing forces in the ICM are minimized thus only 2 sizes of ICAD are required.

## Features

### **Actuator**

- Designed for industrial refrigeration installations
- Advanced and high speed Digital Stepper Motor Technology
- Seven segment LCD display and three programming keys included
- Valve opening degree can be observed continuously
- Can easily be configured to different applications on-site (change speed, ON/OFF, Fail Safe operation, modulating valve, etc..)
- Open – Close time: 3-45 seconds depending on valve size
- Modulating, ON/OFF operation or Neutral zone / 3 point control
- Multiple speed selection during operation
- Logging of old alarms • Password protection
- Control input signal : 4-20 mA, 0-20 mA, 0-10 V, 2-10 V. One or two digital inputs
- Position feed back : 0-20 mA, 4-20 mA (ICM)
- 3 Digital ON/OFF feedback
- Resolution: 20 micron/step (0.02 mm stroke pr. step)
- Total steps: 250 – 3650 depending on size
- Auto Calibration, Neutral zone
- In the event of a power failure, multiple fail safe options are possible. During power failure, ICM can be selected to:
  - Close ICM
  - Open ICM
  - Stay in the same position, as when power failure occurs
  - Go to a specific ICM valve opening degree
- Hermetic magnetic motor
- Enclosure: IP67 ~ NEMA 6
- Approvals: CE, UL, CRN
- Connectors for easy installation and servicing
- ICAD 600A/1200A ensures an accurate feedback on the valve position

**Function**

**ICM function**

Figure 1: ICM Valve

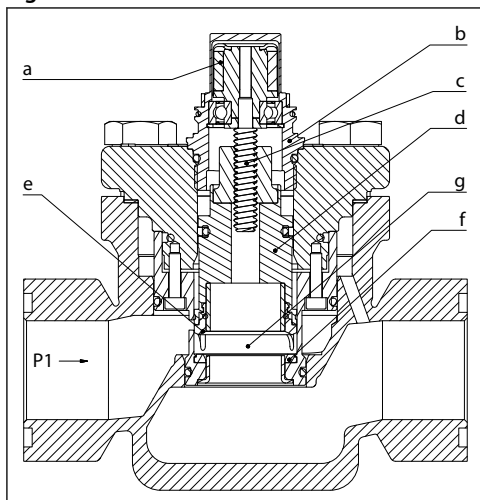

ICM, motor operated valves are designed for use with the ICAD actuator with Display.

The driving force from the actuator is transferred via a magnetic coupling (a) through the stainless steel top housing (b) and thus eliminates the need for a packing gland. The rotational movement of the magnetic coupling (a) is transferred to a spindle (c) which in turn provides the vertical movement of the piston (d) and the valve seat (e), to open and close the valve. The closing force of the actuator, combined with the the valve seat (e) and PTFE valve plate (f), provides an effective seal to prevent leakage across the valve port, when the valve is in the closed position. To prevent damage to the PTFE valve seat (e) and plate (f) from system debris, it is recommended that a filter is installed upstream of the valve.

**ICM 25-65:**

Valve inlet pressure (P1) acting on the underside of the PTFE valve seat (e) also passes through the hollow piston assembly (d) on to the top of the piston (d) and balances the pressure acting on the piston (d). Any trapped liquid across the throttle cone (g) is allowed to equalise down to the valve outlet without affecting the valve performance.

**ICAD**

There are two sizes of ICAD actuator that covers the range of valves from ICM 25 to ICM 65. The actuators have a fully weather protected enclosure with none of the moving parts exposed to the environment.

The fast acting actuators and balanced valve design results in the valve being able to move from the fully closed to the fully open position in between 3 to 45 seconds depending on valve size and ICAD setup.p

**ICAD actuator details**

Actuator types ICAD 600A and 1200A are dedicated for use with ICM motor operated valves. There are only two sizes of ICAD actuators that cover the range of valves from ICM 25 to ICM 65.

The ICAD is controlled via a modulating analogue signal (e.g. 4–20 mA/2–10 V) or a digital ON/OFF signal. ICAD incorporates an advanced MMI (Man Machine Interface), including continuous display of Opening Degree, which gives the user a very advanced and flexible setup procedure that can meet many different applications.

The ICM motor operated valve and ICAD actuator combinations are as follows:

Table 1: ICAD actuator combinations

Actuator	ICAD 600A	ICAD 1200A
Valve size		ICM 40
	ICM 25	ICM 50
	ICM 32	ICM 65

### ICAD 600A / ICAD 1200A

ICAD actuators can be controlled using the following signals:

- 0–20 mA
- 4–20 mA (default)
- 0–10 V
- 2–10 V
- One or two digital Input

ICAD actuators can operate an ICM valve as an On/ Off function supported by one digital input.

ICAD actuators can operate an ICM valve as Neutral zone / 3 point control supported by two digital inputs.

The ICM valve can be operated manually via the ICAD actuator or the Multi-function tool for ICM (see the ordering section).

### Fail Safe supply options

Fail Safe supply options In the event of a power failure, multiple fail safe options are possible, provided that a ICAD-UPS

or similar is used.

During power failure, ICM can be selected to:

- Close ICM
- Open ICM
- Stay in the same position, as when power failure occurs
- Go to a specific ICM valve opening degree

### NOTE:

See the data sheet <https://assets.danfoss.com/documents/240964/AI236186442940en-001302> for further information.

**A fail safe supply (battery or UPS) is required.**

### Actuator

The design of ICAD is based on a digital stepper motor technology combined with an advanced MMI (Man Machine Interface), that gives excellent possibilities for having a high degree of flexibility with the same type of ICAD actuator.

At the ICAD display the Opening Degree (0- 100 %) of the actual ICM valve installed can be continuously observed.

The advanced menu system will allow several parameters to be adjusted to obtain the required function.

Many different parameters can be configured, among these:

- Modulating, ON/OFF operation or Neutral zone / 3 point control
- Analog input 0- 20 mA or 4-20 mA 0-10 V or 2-10 V
- Digital Input ICAD can be configured to support one or two digital inputs. When using one digital input, 0-10 V can not be used at the same time. By using two digital inputs at Neutral zone / 3 point control, the analog input (0/2-10 V, 0/4-20 mA) and Analog Output (0/4-20 mA) can not be used at the same time
- Analog output: 0- 20 mA or 4-20 mA
- Automatic or manual control
- Change of ICM valve speed
- Automatic calibration
- Multiple Fail Safe set-up options during power cut

## Motor and Servo operated valves, type ICM-HMMV and ICM-HMMR

---

For service all Input and Output signals can be recalled and observed from the ICAD display.

A password protection has been linked to the parameter of entering the correct ICM valve to avoid unintentional and non-authorized operation.

ICAD can manage and display different alarms. If an alarm has been detected the display will alternate between showing: Actual alarm present and Opening Degree of ICM valve. If more than one alarm is active at the same time the alarm with the highest priority will take preference. The alarm with the highest priority is shown on the display. All alarms will automatically reset when disappearing.

Previous alarms can be recalled for traceability and service purposes.

Any active alarm will activate the common digital alarm output.

All alarms will automatically reset when disappearing.

ICAD provides two digital output signals to 3rd party control equipment (e.g. PLC) indicating if the ICM valve is completely open or completely closed.

The hermetic magnetic motor coupling makes it easy to dismount the ICAD from ICM valve.

**NOTE:**

For further details on ICAD actuator please see the data sheet <https://assets.danfoss.com/documents/240964/AI236186442940en-001302>

**Product specification**

**Design**

A magnetic coupled actuator is easily installed. Only two actuators are needed to cover the entire ICM program.

Figure 2: ICAD 600A

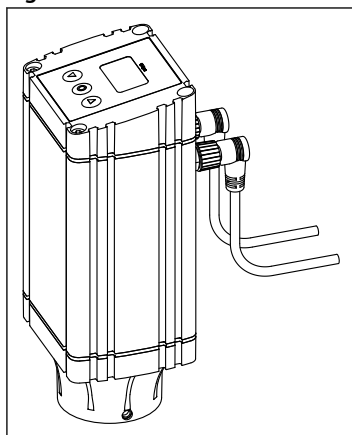
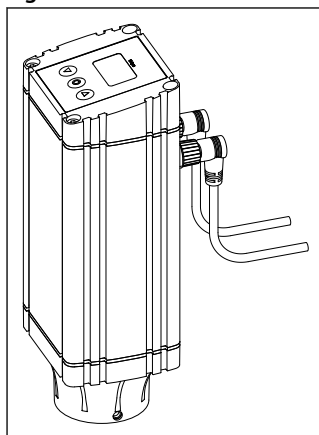

Figure 3: ICAD 1200A



**Materials**

**Housing:** Aluminium

**Top part of ICAD:** PBT thermo plastic

**Weight:**

ICAD 600A: 2.64 lb (1.2 kg)

ICAD 1200A: 4.19 lb (1.9 kg)

**Enclosure:** IP 67 (~NEMA 6)

**Pressure and temperature data**

Table 2: Pressure and temperature data

Temperature range (ambient)	-22 °F/122 °F (-30 °C/+50 °C)
-----------------------------	-------------------------------

**Electrical connection**

Connection to ICAD is done via M12 connectors. ICAD has two M12 male connectors build-in:

**Power supply:** 4 poled M12 male connector

**Control signals:** 8 poled M12 male connector

ICAD can be delivered with (60 in. (1.5 m.)) or without cables with M12 female connectors: Power Supply cable with 4 poled M12 female connector: 3 x ~22 AWG (3 x 0.34 mm<sup>2</sup>) Control cable with 8 poled M12 female connector: 7 x ~24 AWG (7 x 0.25 mm<sup>2</sup>) Cable set with M12 female connectors in other lengths are available. See the section "Spare parts and accessories".

Table 3: Electrical data

Description	Values
Supply voltage	24 V DC, +10%/-15%
Load	ICAD 600A: 1.2 A ICAD 1200A: 2.0 A
Fail safe supply	Min. 19 V DC, Max. 26.4 V DC
Load	ICAD 600A: 1.2 A ICAD 1200A: 2.0 A
Analogue Input	Current or Voltage
Current	0/4–20 mA
Load	200 Ω
Voltage	0/2–10 V DC
Load	10 kΩ
Analogue Output	0/4–20 mA

## Motor and Servo operated valves, type ICM-HMMV and ICM-HMMR

Description	Values
Load	$\leq 250 \Omega$
Digital Input	Digital ON/OFF input by means of volt-free contact (Signal/Telecom relays with gold-plated contacts recommended) – Voltage input used ON: Contact impedance $< 50 \Omega$ OFF: Contact impedance $> 100 \text{ k}\Omega$
Digital Output	3 pcs. NPN transistor output
External supply	5–24 V DC (Same supply as for ICAD can be used, but please note that the galvanically isolated system will then be spoiled)
Output load	$50 \Omega$
Load	Max. 50 mA

**Table 4: Battery capacity - For each open/closed cycle**

Actuator	Speed Parameter i04	ICM 25	ICM 32
ICAD 600A	Max. (i04 = 100)	5 mAh	5 mAh
	Min. (i04 = 1)	467 mAh	533 mAh

**Table 5: Battery capacity - For each open/closed cycle**

Actuator	Speed Parameter i04	ICM 40	ICM 50	ICM 65
ICAD 1200A	Max. (i04 = 100)	17 mAh	22 mAh	22 mAh
	Min. (i04 = 1)	1667 mAh	2167 mAh	2167 mAh

## Cable connection

**Figure 4: Two 1.5 m (60 in) cables pre-mounted**

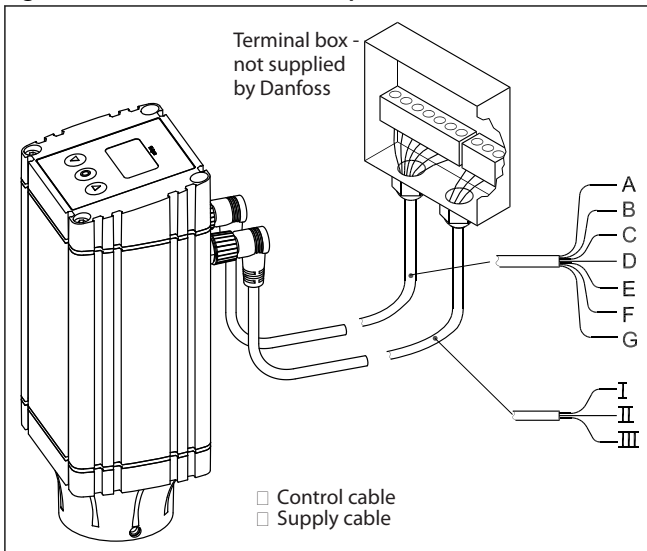

**Figure 5: Connector**

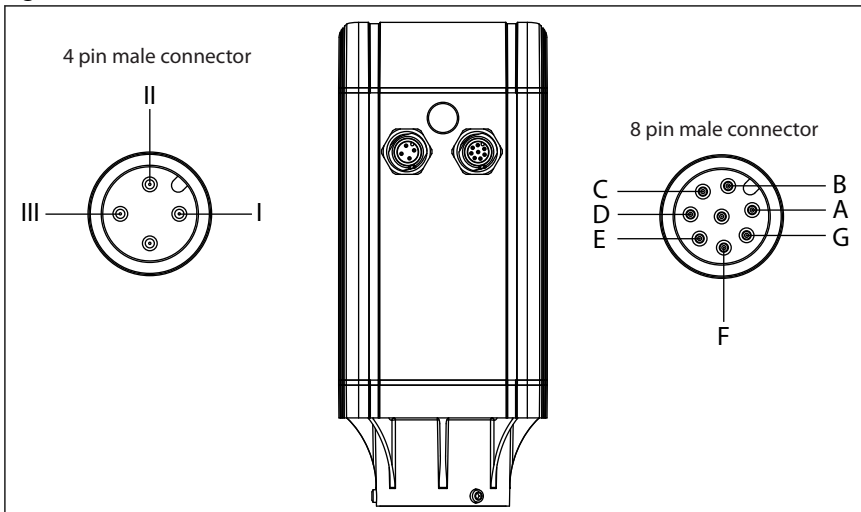

**Table 6: Cable connection**

Ref.	Colour		Description	
A	Black	-	Common Alarm	Digital Output
B	Brown	-	ICM fully open	
C	Red	-	ICM fully closed	
D	Orange	-	GND ground	
E	Yellow	+	0/4-20 mA Input <sup>(3)</sup>	Analogue In/Output
F	Green	+	0/2-10 V Input <sup>(2)</sup>	
G	Blue	+	0/4-20 mA Output <sup>(3)</sup>	
I	Black	+	Fail safe supply Battery / UPS <sup>(1)</sup> 19 V DC	
II	White	+	Supply voltage 24 V DC	
III	Brown	-		

<sup>(1)</sup> Uninterruptable Power Supply

<sup>(2)</sup> Also used with D (GND, ground) for DI1 - Digital ON-OFF operation.

<sup>(3)</sup> If Neutral zone / 3 point control is selected (parameter i02 = 3) then E and G are used as DI2 - Digital ON/OFF input.

**NOTE:**

Colour code changed when compared to older colour wiring diagram.



## Material specification

Figure 6: ICM Parts

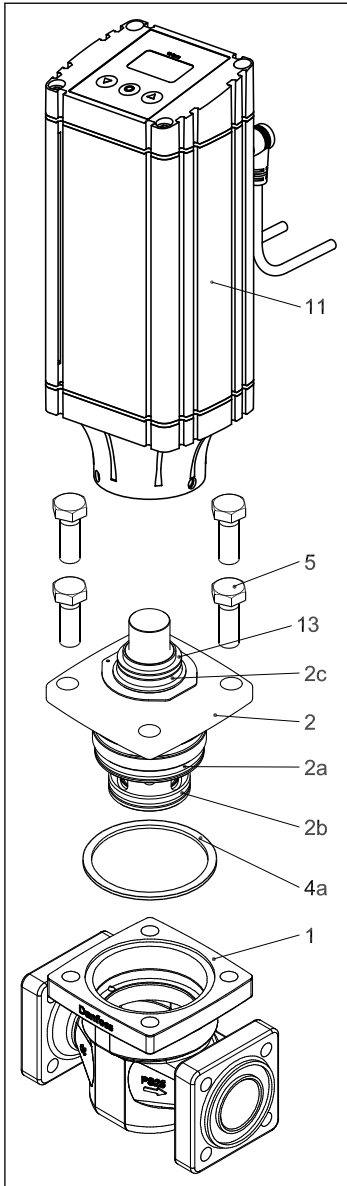

Table 7: Bolt sizes

Type	Screw
ICM 25	M12 × 30 A2-70 DIN 933
ICM 32	M14 × 35 A2-70 DIN 933
ICM 40	M14 × 35 A2-70 DIN 933
ICM 50	M16 × 40 A2-70 DIN 933
ICM 65	M16 × 40 A2-70 DIN 933

Table 8: Parts and material

No.	Part	Material	EN	ASTM	JIS
1	Housing	Low temperature steel	G20Mn5QT, EN 10213-3	LCC, A352	SCPL1, G5151
2	Top cover	Low temperature steel	G20Mn5QT, EN 10213-3	LCC, A352	SCPL1, G5151
2a	O-ring	Cloroprene (Neoprene)			
2b	O-ring	Cloroprene (Neoprene)			
2c	O-ring	Cloroprene (Neoprene)			
3	Function module				
4	Gasket	Cloroprene (Neoprene)			
4a	Gasket	Fiber, non-asbestos			

## Motor and Servo operated valves, type ICM-HMMV and ICM-HMMR

No.	Part	Material	EN	ASTM	JIS
5	Bolts	Stainless steel	A2-70, EN 1515-1	Grade B8 A320	A2-70, B 1054
11	Actuator				
12	O-ring	Cloroprene (Neoprene)			
13	O-ring	Cloroprene (Neoprene)			
14	Seat	High density polymer			

### Capacities

ICM is for each size available in 2 variants for low and high capacity.

Figure 7: ICM with ICAD actuator    Figure 8: ICM Valve



Table 9: Valve capacities

Type	Valve body size	$C_v$ (US gal/min)	$K_v$ (m <sup>3</sup> /h)
ICM 25-HMMR	25	7.0	6
ICM 25-HMMV		13.9	12
ICM 32-HMMR	32	10.4	9
ICM 32-HMMV		20	17
ICM 40-HMMR	40	17	15
ICM 40-HMMV		30	26
ICM 50-HMMR	50	27	23
ICM 50-HMMV		46	40
ICM 65-HMMR	65	41	35
ICM 65-HMMV		81	70

## Dimension and weight

Figure 9: Dimension and weight

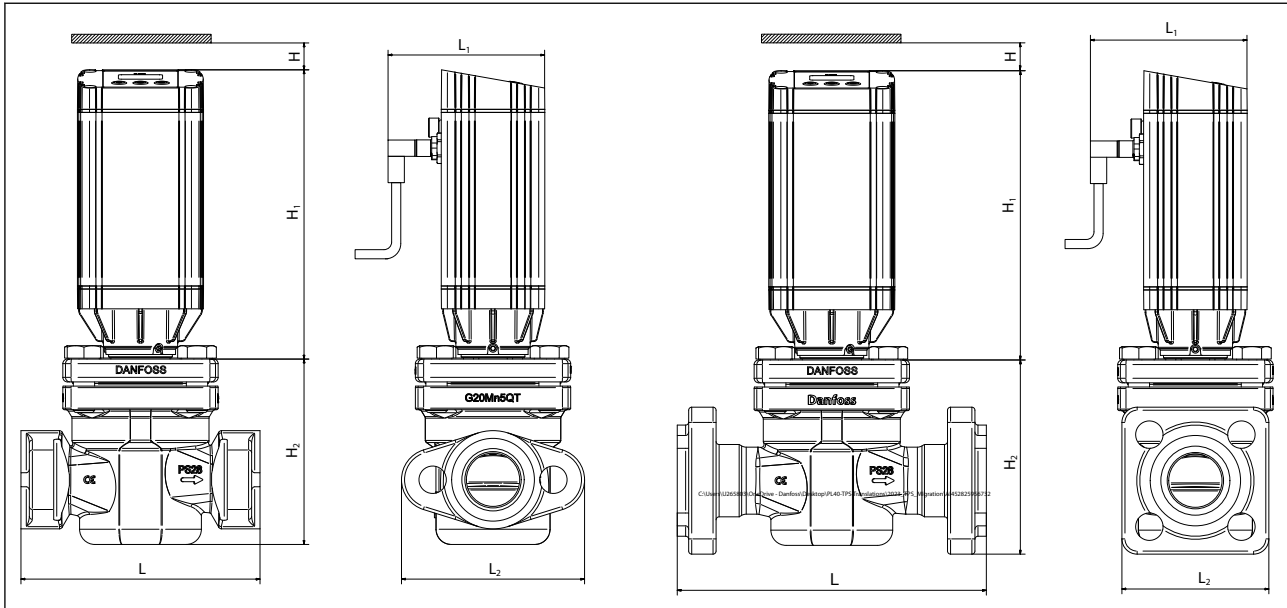

Table 10: Dimension and weight

Valve size		L	L <sub>1</sub>	L <sub>2</sub>	H	H <sub>1</sub>	H <sub>2</sub>	Weight ICM incl. ICAD
25 HMMR(V) 1 in.	in.	6.2	4	4.7	1.6	7.7	4.1	11.9 lb
	mm	157	102	118.4	40	195	104.5	5.4 kg
32 HMMR(V) 1 1/4 in.	in.	6.2	4	4.7	1.6	7.7	4.8	15.6 lb
	mm	157	102	120.2	40	195	121.8	7.1 kg
40 HMMR(V) 1 1/2 in.	in.	9.9	4	4.7	1.8	8.6	5.6	28.2 lb
	mm	251	102	120	45	219	143.1	12.8 kg
50 HMMR(V) 2 in.	in.	9.9	4	4.7	1.8	8.6	6.4	34.1 lb
	mm	251	102	120	45	219	162.1	15.5 kg
65 HMMR(V) 2 1/2 in.	in.	9.9	4	5.7	1.8	8.6	7.7	50.8 lb
	mm	251.5	102	145	45	219	196.6	23.1 kg

## Ordering

**Table 11: Ordering**

Type	C <sub>v</sub> [gpm]	K <sub>v</sub> [m <sup>3</sup> /h]	Code number
ICM 25 HMMR 1 in. incl. ICAD, control cable 9.84 ft and supply cable 9.84 ft. <sup>(1)</sup>	7.0	6	148X0859
ICM 32 HMMR 1 1/4 in. incl. ICAD, control cable 9.84 ft and supply cable 9.84 ft. <sup>(1)</sup>	10.4	9	148X0861
ICM 40 HMMR 1 1/2 in. incl. ICAD, control cable 9.84 ft and supply cable 9.84 ft. <sup>(1)</sup>	17	15	148X0862
ICM 50 HMMR 2 in. incl. ICAD, control cable 9.84 ft and supply cable 9.84 ft. <sup>(2)</sup>	27	23	148X0863
ICM 65 HMMR 2 1/2 in. incl. ICAD, control cable 9.84 ft and supply cable 9.84 ft. <sup>(2)</sup>	41	35	148X0864
ICM 25 HMMV 1 in. incl. ICAD, control cable 9.84 ft and supply cable 9.84 ft. <sup>(1)</sup>	13.9	12	148X0865
ICM 32 HMMV 1 1/4 in. incl. ICAD, control cable 9.84 ft and supply cable 9.84 ft. <sup>(2)</sup>	20	17	148X0867
ICM 40 HMMV 1 1/2 in. incl. ICAD, control cable 9.84 ft and supply cable 9.84 ft. <sup>(1)</sup>	30	26	148X0868
ICM 50 HMMV 2 in. incl. ICAD, control cable 9.84 ft and supply cable 9.84 ft. <sup>(2)</sup>	46	40	148X0869
ICM 65 HMMV 2 1/2 in. incl. ICAD, control cable 9.84 ft and supply cable 9.84 ft. <sup>(2)</sup>	81	70	148X0892

<sup>(1)</sup> Includes flange gaskets and flange bolts

<sup>(2)</sup> Includes flange gaskets, flange bolts and flange nuts

### Accessories

**Figure 10: ICAD-UPS**



**Table 12: ICAD-UPS**

Description	Code no.
ICAD-UPS	027H0182

**Figure 11: Multi-funtion tool**

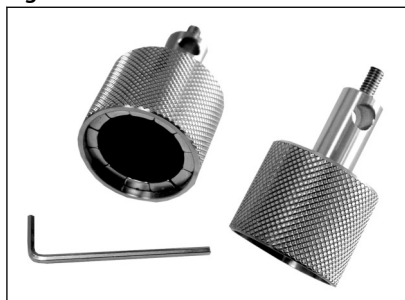

**Table 13: Multi-funtion tool**

Description	Code no.
Multi-function tool for ICM 25-32	027H0180
Multi-function tool for ICM 40-65	027H0181

Figure 12: Cable for ICAD

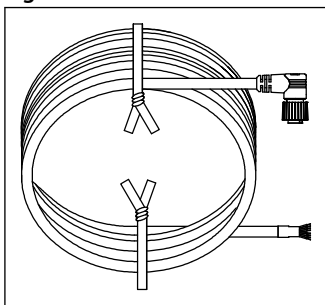

Table 14: Cable for ICAD 600A / 1200A

Cable length (all female)	Code no.
4.92 ft. (1.5 m)	027H0426
9.84 ft. (3 m)	027H0438
32.81 ft. (10 m)	027H0427
49.21 ft. (15 m)	027H0435

Figure 13: Connectors for ICAD

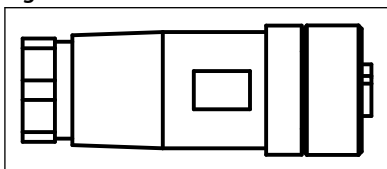

Table 15: Connectors for ICAD 600A / 1200A

Connector type	Code no.
Two Female Connectors with screw terminals: - connector for power - connector for control signals	027H0430

Figure 14: Protection cap for ICAD

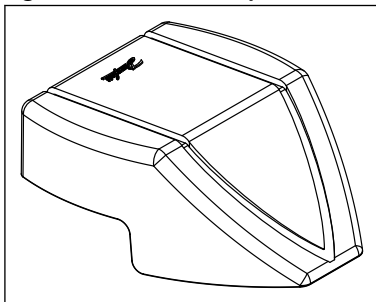

Table 16: Protection cap for ICAD 600A / 1200A

Description	Code no.
Protection cap	027H0431

**Certificates, declarations, and approvals**

The list contains all certificates, declarations, and approvals for this product type. Individual code number may have some or all of these approvals, and certain local approvals may not appear on the list.

Some approvals may change over time. You can check the most current status at danfoss.com or contact your local Danfoss representative if you have any questions.

**Valid approvals**

**ICM**

The ICV valve concept is designed to fulfil global refrigeration requirements.

ICM is CE, UL and CRN approved.

For specific approval information, please contact Danfoss.

The ICM valves are approved in accordance with the European standard specified in the Pressure Equipment Directive and are CE marked. For further details / restrictions - see Installation guide.

**Table 17: Conformity approvals**

ICM valves				
	Nominal bore	DN ≤ 25 (1 in.)	DN 32 – 65 (1 1/4 – 2 1/2 in.)	DN 80 – 125 (3 – 5 in.)
	Classified for	Fluid group I		
	Category	Article 3, paragraph 3	II	III

**ICAD**



CE according to 89/336 EEC (EMC)

Emission : EN61000-6-3

Immunity: EN61000-6-2

**REACH requirements**

All Danfoss products fulfill the requirements in REACH. One of the obligations in REACH is to inform customers about presence of Candidate list substances if any, we hereby inform you about one substance on the candidate list: An O-ring used in ICAD 600A actuator contains 6,6'-di-tert-butyl-2,2'-metylenodi-p-krezol (CAS no: 119-47-1) in a concentration above 0.1% w/w.

## Online support

Danfoss offers a wide range of support along with our products, including digital product information, software, mobile apps, and expert guidance. See the possibilities below.

### The Danfoss Product Store



The Danfoss Product Store is your one-stop shop for everything product related—no matter where you are in the world or what area of the cooling industry you work in. Get quick access to essential information like product specs, code numbers, technical documentation, certifications, accessories, and more.

Start browsing at [store.danfoss.com](https://store.danfoss.com).

### Find technical documentation



Find the technical documentation you need to get your project up and running. Get direct access to our official collection of data sheets, certificates and declarations, manuals and guides, 3D models and drawings, case stories, brochures, and much more.

Start searching now at [www.danfoss.com/en/service-and-support/documentation](https://www.danfoss.com/en/service-and-support/documentation).

### Danfoss Learning



Danfoss Learning is a free online learning platform. It features courses and materials specifically designed to help engineers, installers, service technicians, and wholesalers better understand the products, applications, industry topics, and trends that will help you do your job better.

Create your Danfoss Learning account for free at [www.danfoss.com/en/service-and-support/learning](https://www.danfoss.com/en/service-and-support/learning).

### Get local information and support



Local Danfoss websites are the main sources for help and information about our company and products. Find product availability, get the latest regional news, or connect with a nearby expert—all in your own language.

Find your local Danfoss website here: [www.danfoss.com/en/choose-region](https://www.danfoss.com/en/choose-region).

### Spare Parts



Get access to the Danfoss spare parts and service kit catalog right from your smartphone. The app contains a wide range of components for air conditioning and refrigeration applications, such as valves, strainers, pressure switches, and sensors.

Download the Spare Parts app for free at [www.danfoss.com/en/service-and-support/downloads](https://www.danfoss.com/en/service-and-support/downloads).

### Coolselector®2 - find the best components for you HVAC/R system



Coolselector®2 makes it easy for engineers, consultants, and designers to find and order the best components for refrigeration and air conditioning systems. Run calculations based on your operating conditions and then choose the best setup for your system design.

Download Coolselector®2 for free at [coolselector.danfoss.com](https://coolselector.danfoss.com).

### Danfoss A/S

Climate Solutions • [danfoss.com](https://danfoss.com) • +45 7488 2222

Any information, including, but not limited to information on selection of product, its application or use, product design, weight, dimensions, capacity or any other technical data in product manuals, catalogues descriptions, advertisements, etc. and whether made available in writing, orally, electronically, online or via download, shall be considered informative, and is only binding if and to the extent, explicit reference is made in a quotation or order confirmation. Danfoss cannot accept any responsibility for possible errors in catalogues, brochures, videos and other material. Danfoss reserves the right to alter its products without notice. This also applies to products ordered but not delivered provided that such alterations can be made without changes to form, fit or function of the product.

All trademarks in this material are property of Danfoss A/S or Danfoss group companies. Danfoss and the Danfoss logo are trademarks of Danfoss A/S. All rights reserved.