



Fan Speed Controllers Type RGE

Contents

	Page
Introduction	3
Features.....	3
Specifications.....	4
Adjusting Method	5
Operation	5
Dimensions.....	6
Wiring	7
Installation	7

Introduction

Saginomiya type RGE condenser fan speed controllers are compact, robust phase controllers designed for application on condensing units and packaged air-conditioning systems. They are particularly suitable in units that operate the year around, and provide stable operation with constant condensing pressure during winter or moderate seasons. RGE controllers make possible cost-efficient variable control of fan speed.

**Features**

- Pressure sensing element integrated.
- Sensor-bellows structure provides high reliability
- Single phase and 3 phase versions available.
- All common refrigerants R22, R407C, R404A, R134a, R410A
- Designed for reduced-noise operation
- Selectable slowdown mode or cut-off mode
- ¼" female connection with schraeder depressor pin
- Terminal for an external forced operation switch is provided.
- IP54 enclosure
- CSA-us approved
- CE and EMC

Specifications

Common specifications:

- Control method: Phase control
- Enclosure: IP54

Danfoss Code No.	Catalog No.	F.V.S. Setting Adjusting Range (psi) ¹	E.P.B. (psi) Fixed ²	Max. Working Pressure (psi)	Electrical Rating		Function	Ambient Temp. (°F)	Refrigerants	Factory Set (psi)	Wt. (kg)				
					Voltage	Ampere									
061H3045	RGE-Z1L4-7DS	116 to 406	87	681	Single phase 200 to 240V AC 50/60Hz	0.2 to 2A	At approx. 45% (50Hz) at approx 35% (60Hz). Cut Off or Minimum Speed function is selectable with changeover switch. Default setting: Cut Off	-4 to 131	R22, R404A, R407C (R134a)	276 ³	0.36				
061H3005	RGE-Z1N4-7DS		0.2 to 4A			0.50									
061H3008	RGE-Z1P4-7DS		58			0.2 to 6A					0.54				
061H3009	RGE-Z1Q4-7DS		0.2 to 8A			0.58									
061H3048	RGE-Z1L6-7DS	232 to 566	116			0.2 to 2A					0.36				
061H3021	RGE-Z1N6-7DS					0.2 to 4A					0.50				
061H3022	RGE-Z1P6-7DS					0.2 to 6A					0.54				
061H3023	RGE-Z1Q6-7DS					0.2 to 8A					0.58				
061H3003	RGE-Z3R4-7DS	116 to 406	58	681	Three phase 200 to 240V AC 50/60Hz	0.2 to 5A	At approx. 35%, Cut Off or Minimum Speed function is selectable with changeover switch. Default setting: Min. speed	-4 to 122	R22, R404A, R407C (R134a)	232 ³	1.40				
061H3050	RGE-Z3T4-7DS		87			0.2 to 7A					1.53				
061H3027	RGE-Z3R6-7DS	232 to 566	116			0.2 to 5A					1.40				
061H3051	RGE-Z3T6-7DS					0.2 to 7A					1.53				
061H3006	RGE-X3R4-7DS	116 to 406	58			Three phase 380 to 415V AC 50/60Hz					0.2 to 5A	5 to 122	R22, R404A, R407C (R134a)	232 ³	1.40
061H3028	RGE-X3R6-7DS	232 to 566	116												

¹ The pressure at which the control delivers 95% output effective voltage (VRMS).

² Pressure width where effective voltage corresponds to the minimum speed or causes cut off operation.

³ When the refrigerant is R134a, please change the pressure setting.

Minimum speed: Fan motor will be kept running at minimum speed when pressure decrease to the set value, (the specific value (V%)).

Cut off: Fan motor will be stopped when pressure decreases to the specific value (V%) for R.M.S.

Adjusting Method

- 1) Range adjustment
 Setting point is increased by turning the range adjusting screw clockwise. It is decreased by turning the screw counter-clockwise.
 Adjustment should be within the range indicated for the setting pointer.
- 2) Lower pressure operation selection
 Following operation are selectable with the change-over switch.
 Minimum speed running : Fan motor operates at the Minimum speed when the pressure decreases below the value "Pmin".
 Cut-off : Fan motor stops when the pressure decreases below the value "Pmin".

$$Pmin = F.V.S - E.P.B.$$

F.V.S = Pressure setting for max. speed (Adjustable)

E.P.B = Effective Proportional Band (Fixed)

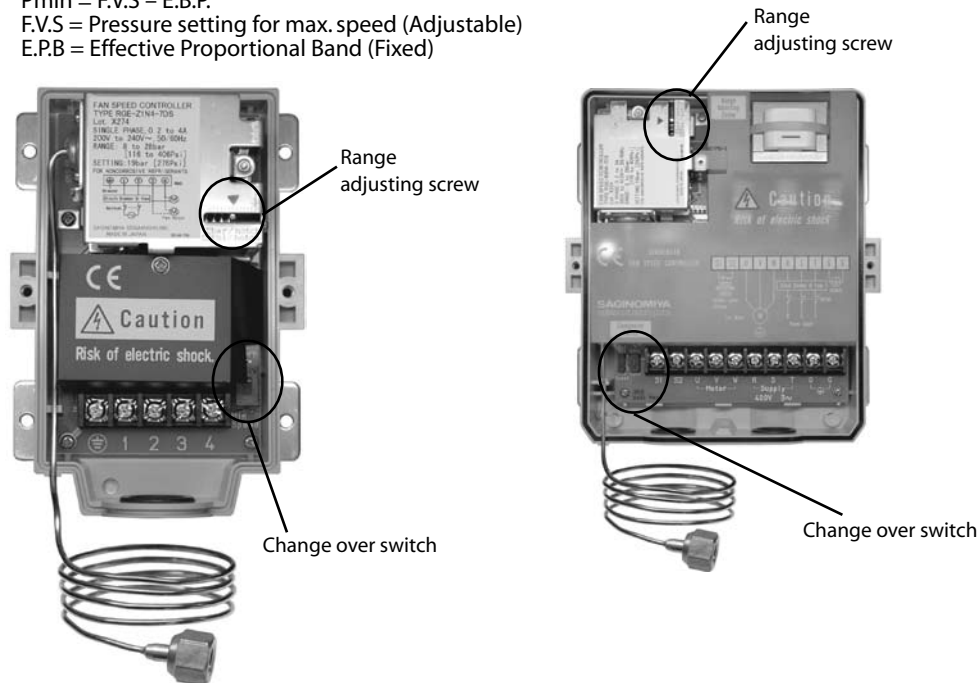

Operation

① Single-phase type (RGE-Z1)

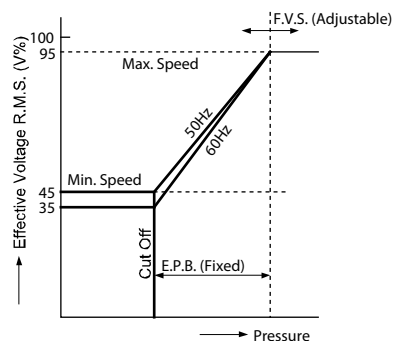

② Three-phase type (RGE-Z3,X3)

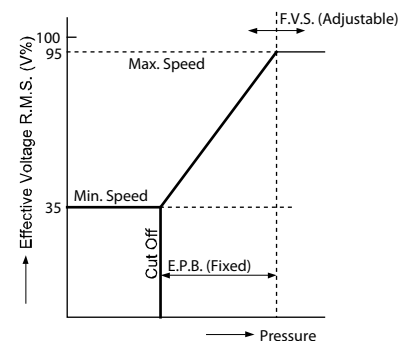

The operating characteristic may vary according to the voltage, frequency, and fan motor characteristics.

Dimensions

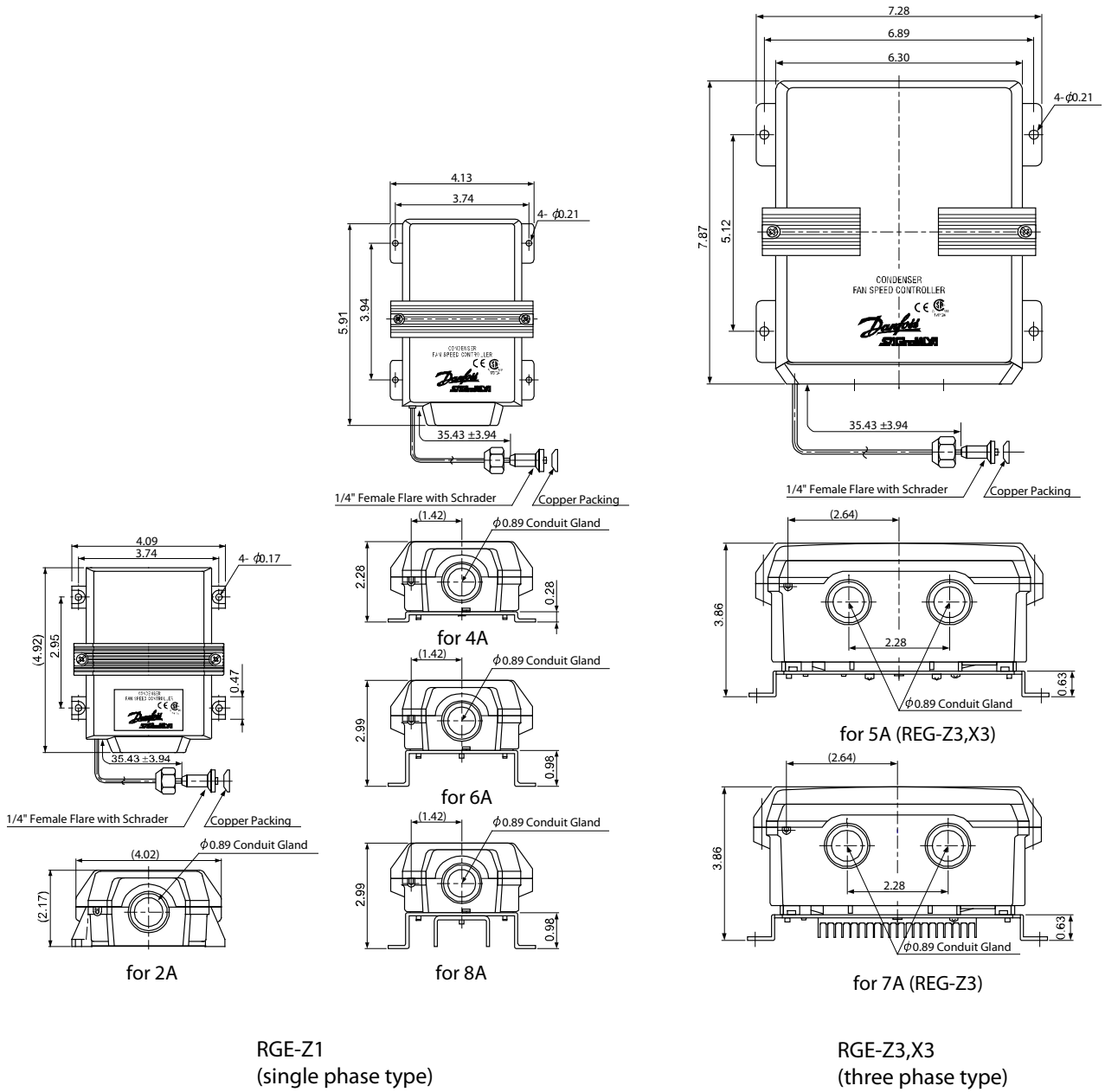

Wiring

Single-phase type

for 4A,6A,8A(RGE-Z1)

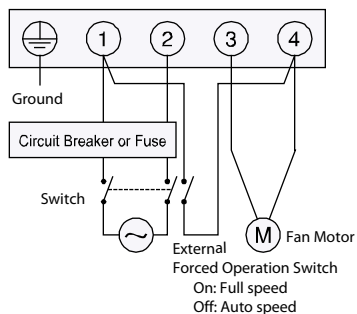

Three-phase type

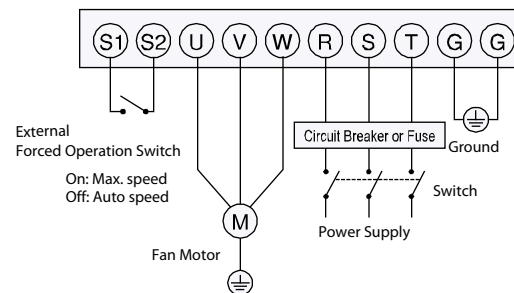

for 2A(RGE-Z1)

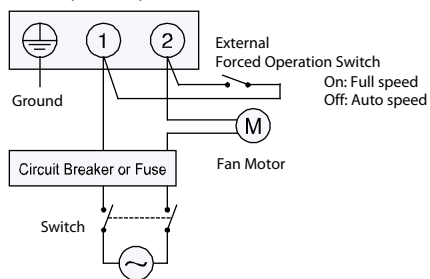

Installation

1. Mount on flat surface with conduit connection downward.
2. Connect the pressure sensing element so as to sense head pressure.
3. If installing the controller outside the unit housing, protect human hand from direct touching.
4. Do not use RGE with ammonia systems.
5. Connect RGE only to fan motor.
6. Operate only with cover in place.
7. Turn off the power supply before adjusting the setting or operating the change-over switch.

