

User Guide

Controller for cascade systems with CO₂ EKC 313

ADAP-KOOL® Refrigeration control systems



Introduction

Application

The controller can be used in systems with cascade regulating and CO₂ as refrigerant on the low temperature circuit. It regulates the cooling of the heat exchanger to optimise super-heat.

Advantages

- Dedicated cascade controller

System

The controller must receive a signal from two pressure transmitters and two temperature sensors. The pressure transmitters must have a type AKS 32R or AKS 2050 ratiometric output signal, as determined by the actual pressure conditions. The signal from the pressure transmitters can be a voltage signal of either 0-10 V or 1-5 V.

Type AKS 11 temperature sensors can be used, but type AKS 21 must be used if the temperature exceeds 100°C.

Functions

Output signal

The controller has a voltage output on 0-10 V.

The signal can be used for:

- Indicating the valve's opening degree when using an ETS valve
- Controlling the valve when using an ICAD/ICMTS valve

Valves opening degree

The valve's opening degree can be limited.

Relay

The relay in the controller can be used for:

- Alarm relay
- Control of solenoid valve in liquid line

Start/stop

A switch can be connected for starting and stopping the regulation.

PC-operation

The controller can be provided with data communication so that it can be connected to other products in the range of ADAP-KOOL® refrigeration controls. In this way operation, monitoring and data collection can be performed from one PC – either on the spot or in a service company.

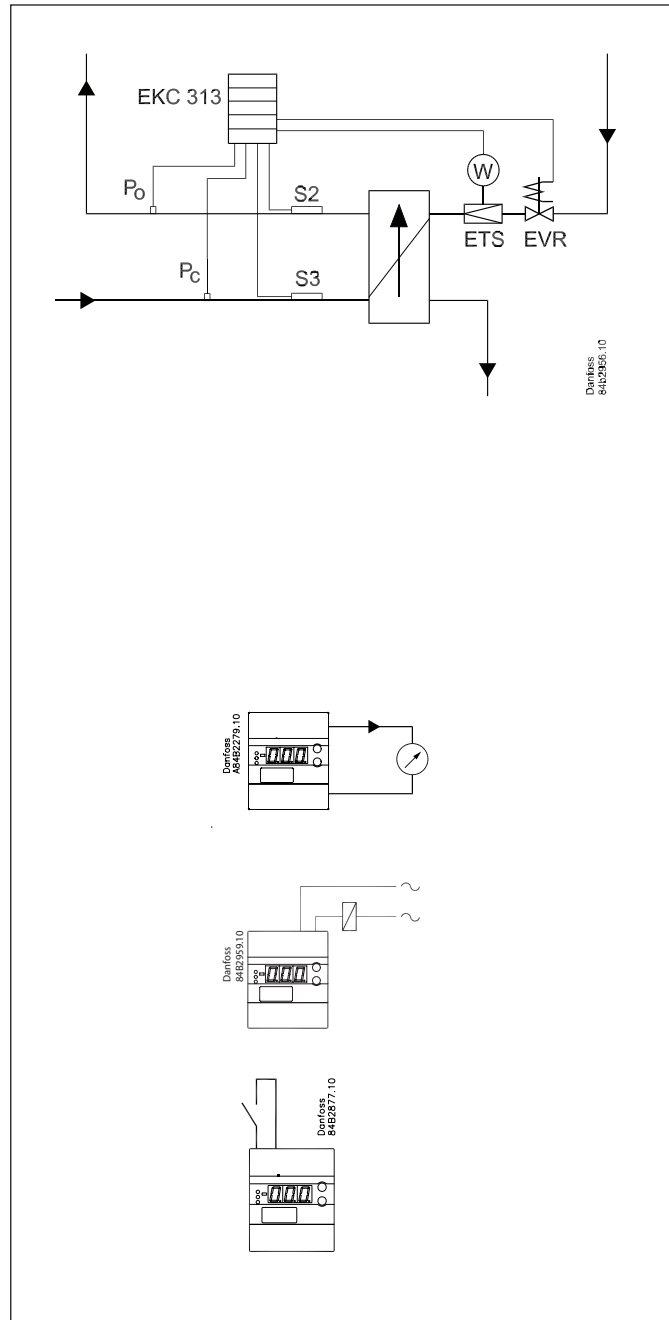

Contents

Introduction	2	Menu survey.....	8
Example	3	Connections.....	10
Function overview	4	Data.....	11
Operation	8	Ordering.....	11

Example

Optimised superheat regulation with limit if the condensing pressure is low.

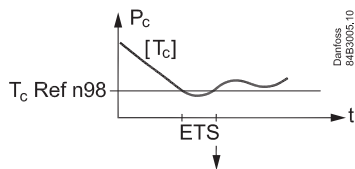
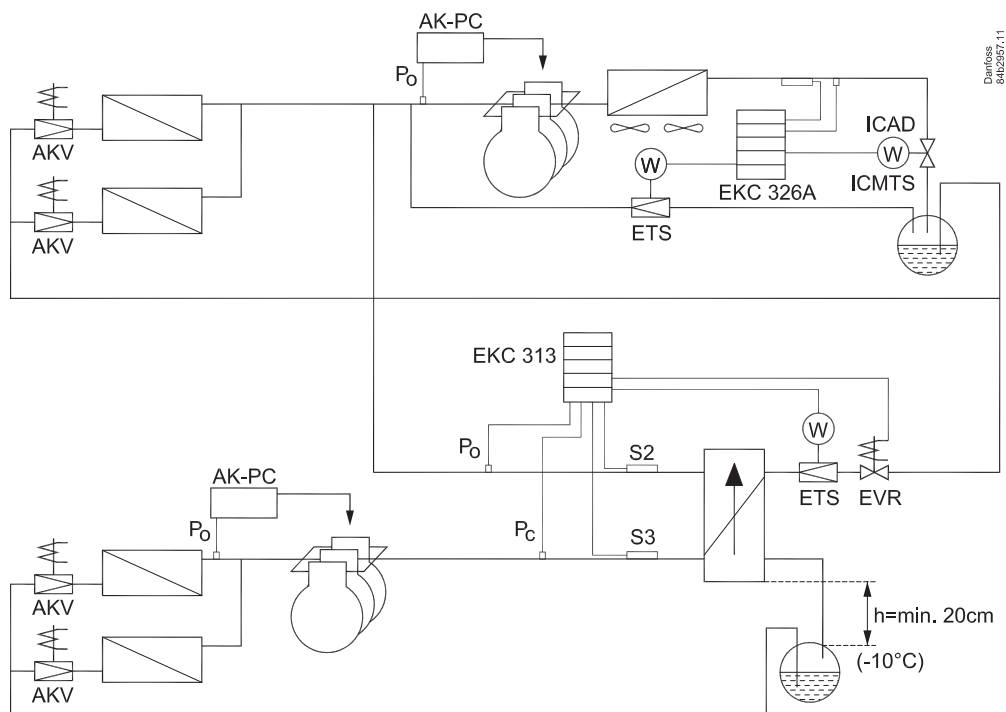

Optimised superheat regulation is used when the condensing pressure is above the set value.
 If the condensing pressure falls below the set value, the optimised superheat regulation ceases and the ETS valve closes gradually until the pressure rises above the value.

Function overview

Function	Parameter	Parameter by operation via data communication
Normal display		
Displays either the valve's actual opening degree or the actual superheat value. (Desired value can be set in o17) Briefly pushing the bottom button will display one of the two readings. Briefly pushing both buttons will display the superheat reference (u22).	u24 / u21	Valve OD % SH
Control parameters		Injection control
Start/stop of regulation This setting can be used to start and stop regulation.	r12	Main Switch
I: Integration time Tn If the Tn value is increased the regulation becomes slower	n05	Tn sec.
Lower limit value for the condensing pressure. If the pressure falls, the valve will start closing.	n98	Tc Ref
Max. opening degree The valve's opening degree can be limited here. The setting is expressed as a % of the total opening degree. The voltage signal of 0-10 V on the output will be limited correspondingly.	n32	OD% Max
Amplification factor for the superheat This setting determines the valve's opening degree as a function of the change in evaporating pressure. An increase of the evaporating pressure will result in a reduced opening degree. When there is a drop-out on the low-pressure thermostat during start-up the value must be raised a bit. If there is pending during start-up the value must be reduced a little. The value should only be changed by specially trained staff.	n20	Kp T0
Kp value for amplification factor for PID regulation	n95	Kp Max
Kp value near reference value Just around the reference this value will be used in stead of the "n95 value" The value should only be changed by specially trained staff.	n19	Kp Min
Signal safety during start-up The control function uses the value as start value for the valve's opening degree at each thermostat cutin. By adaptive control the controller continuously calculates a new value. The value should only be changed by specially trained staff.	n17	Start OD%
Start-up time for safety signal If the controller does not obtain a reliable signal within this period of time the controller will in other ways try to establish a stable signal. (A too high value may result in a flooded evaporator). The value should only be changed by specially trained staff.	n15	StartUp time
MOP If no MOP function is required, select pos. Off. (A value of max. (60) will correspond to Off)	n11	MOP (bar)
Min. value for the superheat reference	n10	SH Min
Max. value for the superheat reference	n09	SH Max
D: Differentiation time Td	n06	Td sec

Configuration		Control config
Refrigerant setting on evaporator side Before refrigeration can be started, the refrigerant must be defined. You can select the following refrigerants: 1=R12. 2=R22. 3=R134a. 4=R502. 5=R717. 6=R13. 7=R13b1. 8=R23. 9=R500. 10=R503. 11=R114. 12=R142b. 13=User defined. 14=R32. 15=R227. 16=R401A. 17=R507. 18=R402A. 19=R404A. 20=R407C. 21=R407A. 22=R407B. 23=R410A. 24=R170. 25=R290. 26=R600. 27=R600a. 28=R744. 29=R1270, 30=R417A. 31=R422A. 32=R413A. 33=R422D. 34=R427A. 35=R438A. (Warning: Wrong selection of refrigerant may cause damage to the compressor).	o30	P0 Rfg type
Refrigerant setting on the condenser side Factory-set to R744, but can be changed. A modification can only be made via AKM.	-	Pc Rfg type
Actuator type 0: ETS 12½ and ETS 25 / CCM 10 and CCM 20 1: ETS 50 / CCM30 2: ETS 100 / CCM40 3: ETS 250 4: ETS 400 5: Other type. "n37" and "n38" should also be set when the setting = 5 ("n37" and "n38" are automatically set for settings 0 to 4) 6: 0-10 V output must control an ICAD actuator 7: 0-10 V output must control a solid state relay, which, in turn, controls an AKV valve (the signal will be an on/off signal [0 or 10 V]) NB! ETS 6 can not be used	n03	Valve type
ETS Setting Number of steps from 0% to 100% open Must only be set when "n03" is set to 5. Automatically set when "n03" is set to 0, 1, 2, 3 or 4	n37	Max. steps
ETS setting Spindle stroke speed (number of steps per second) Must only be set when "n03" is set to 5. Automatically set when "n03" is set to 0, 1, 2, 3 or 4	n38	Steps / sec
Miscellaneous		Miscellaneous
Address If the controller is built into a network with data communication, it must have an address, and the master gateway of the data communication must then know this address. These settings can only be made when a data communication module has been mounted in the controller and the installation of the data communication cable has been completed. This installation is mentioned in a separate document "RC8AC"		Following installation of a data communication module, the controller can be operated on a par with the other controllers in ADAP-KOOL® refrigeration controls.
The address is set between 0 and 119 (999)	o03	-
The address is sent to the gateway when the menu is set in pos. ON (The setting will automatically change back to Off after a few seconds.)	o04	-
Pressure transmitter selection 1: Ratiometric with AKS 32R / AKS 2050 2: Voltage signal with 0-10 V 3: Voltage signal with 1-5 V	o10	Trans. type
Pressure transmitter definition for Pc. Pressure transmitter lower limit	o20	MinTransPc
Pressure transmitter definition for Pc. Pressure transmitter upper limit	o21	MaxTransPc
Pressure transmitter definition for P0. Pressure transmitter lower limit	o47	MinTransP0
Pressure transmitter definition for P0. Pressure transmitter upper limit	o48	MaxTransP0
Frequency Set the net frequency.	o12	50 / 60 Hz (50=0, 60=1)
Definition of relay The relay can be defined for the following applications: 0: Alarm relay 1: Control of EVR-valve in liquid line.	o36	Alarm/Valve

Display view Normal display on the controller can be set to read one of the following readings: 1: Valve's opening degree 2: Superheat	o17	Display mode
Only access via data communication		For Danfoss only
Factor for calculating the superheat reference $SH_{ref} = (S3 - P0) \times SH_{factor} / 100$	n96	SH factor
Filter constant (delay) for calculating the superheat reference	n97	Ref Filter
Other refrigerant If the refrigerant type cannot be selected directly via settings 1 through 33, it can then be defined by the user. Select setting 13 and then set the refrigerant's three constants via AKM.		P ₀ Rfg.Fac A1 P ₀ Rfg.Fac A2 P ₀ Rfg.Fac A3 P _c Rfg.Fac A1 P _c Rfg.Fac A2 P _c Rfg.Fac A3
Service		Service
A number of controller values can be printed for use in a service situation		
Read status of input DI (start/stop input)	u10	DI status
Read the temperature at the S3 sensor	u12	S3 Temp
Read the temperature at the S2 sensor	u20	S2 Temp
Read the control's actual superheat	u21	SH
Read the control's actual superheat reference	u22	SH Ref
Read the ETS valve's opening degree	u24	Valve OD %
Reading the calculated closing value for superheating.	U19	SH Close
Reading the condensation pressure calculated for temperature	U20	Cond Temp Tc
Reading the condensation pressure (pressure at Pc)	U21	Cond Press Pc
Reading the evaporating pressure (pressure at P0)	U25	Evap Press P0
Reading the evaporating pressure calculated for temperature	U26	Evap Temp T0
Manual control of outputs For service purposes the valve outputs can be forced However only when regulation has been stopped. 0: No override 1: Override: If the relay is defined for solenoid valve use in o36, the solenoid valve will open. The opening degree of the ETS or ICMTS valve can then be set via o45.	o18	Manual Ctrl
Manual control of the ETS valve When "o18" is activated (=1) the valve's opening degree can be determined from this menu.	o45	Man Valve OD%
Operating status		
The controller's operating status can be called forth by a brief (1s) activation of the upper button. If a status code exists it will be shown. (Status codes have lower priority than alarm codes. This means that status codes cannot be seen if there is an active alarm code. The individual status codes have the following meanings:		EKC State (0 = regulation)
S10 (off): Regulation stopped by the internal start/ stop.		10
S24: Regulation is in start-up mode		24
S44: Delay time, or the time it takes for system stability to be reached. Appears if one of the regulating sensors fails.		44

Alarms	
The controller can give the following alarms. The alarm priority for all alarms is factory-set to 1, "High priority". The priority level can be modified, but only by altering the data communication settings.	Alarm destinations
E1: Fault in controller	Controller fault
E15: Cut-out S2 sensor	S2 o.c.
E16: Short circuited S2 sensor	S2 s.c.
E17: Cut-out S3 sensor	S3 o.c.
E18: Short circuited S3 sensor	S3 s.c.
E20: Fault on signal from Pc	Pc input err
E39: Fault on signal from P0	P0 input err
A11: No refrigerant has been selected. o30 must be set	No Rfg. Sel.
A43: Step motor fault. Output or phase	Step motor err
A45: Regulation stopped. Main switch r12 = off	Standby mode

Operation

Display

The values will be shown with three digits.
Temperature are shown in °C and pressure in bar.

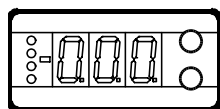

Light-emitting diodes (LED) on front panel

All 4 light-emitting diodes will flash when there is an error in the regulation.

In this situation you can upload the error code on the display and cancel the alarm by giving the uppermost button a brief push.

The controller can give the following messages:		
E1	Error message	Fault in controller
E15		Cut-out S2 sensor
E16		Short circuited S2 sensor
E17		Cut-out S3 sensor
E18		Short circuited S3 sensor
E20		Fault on signal from Pc
E39		Fault on signal from P0
A11	Alarm message	No refrigerant has been selected
A43		Step motor fault. Output or phase
A45		Regulation stopped. Main switch r12 = off

The buttons

When you want to change a setting, the two buttons will give you a higher or lower value depending on the button you are pushing. But before you change the value, you must have access to the menu. You obtain this by pushing the upper button for a couple of seconds - you will then enter the column with parameter codes. Find the parameter code you want to change and push the two buttons simultaneously. When you have changed the value, save the new value by once more pushing the two buttons simultaneously.

- Gives access to the menu (or cutout an alarm)
- Gives access to changes
- Saves a change

Examples of operations

Set of a menu

1. Push the upper button until a parameter is shown
2. Push one of the buttons and find the parameter you want to change
3. Push both buttons simultaneously until the parameter value is shown
4. Push one of the buttons and select the new value
5. Push both buttons again to conclude the setting

*) This setting will only be possible if a data communication module has been installed in the controller.

**) The display on the controller can show 3 digits only, but the setting value has 4 digits. Only the 3 most important will be shown. It means fx. 250 will give a setting of 2500.

Menu survey

SW =2.0x

Function	Parameter	Min.	Max.	Fac.set-ting
Normal display				
Displays either the valve's current opening degree or the current superheat value. (Can be set in o17)				
Briefly pushing the bottom button will display one of the two readings.				
Briefly pushing both buttons will display the superheat reference (u22).				
Start / stop				
Start / stop af regulation	r12	OFF (0)	On (1)	On (1)
Regulating parameters				
Select valve type:				
0=ETS 12,5 & 25 / CCM10 & CCM20				
1=ETS 50 / CCM30, 2=ETS 100 / CCM40				
3=ETS 250, 4=ETS 400,				
5=User defined (set : n37 and n38)				
6=0-10 V's output must control ICAD actuator				
7=0-10 V's output must on/off control a solid state relay.				
I: Integration time Tn	n05	5 s	600 s	90
D: Differentiation time Td	n06	0 s	60 s	0
Max. value of superheat reference	n09	3 K	60 K	40
Min. value of superheat reference	n10	3 K	40 K	10
MOP (max. = Off)	n11	0 bar	60 bar	60
Signal reliability during start-up. Time for safety. Should only be changed by trained staff	n15	0 s	240 s	0
Signal reliability during start-up - Opening degree's start value. Should only be changed by trained staff.	n17	0%	100%	0
Kp amplification just around reference value Changes should only be made by trained staff	n19	0	30	3
Amplification factor for superheat. (KpT0) Changes should only be made by trained staff	n20	0	30	5
Max. opening degree of valve	n32	0%	100%	100
Number of steps from 0-100% opening degree (x10)**	n37	0	500	263
Number of steps per second	n38	0	300	250
Max. Kp factor for PID-regulation (Kp max)	n95	0	30	5
Calculation factor for superheat SH Changes should only be made by trained staff	n96	10	100	50
Filter constant for SH reference Changes should only be made by trained staff	n97	5 s	600 s	60
Lower limit value for the condensing pressure	n98	-30°C	10°C	-5
Miscellaneous				
Controller's address (0 = off)	o03*	0	119	0
ON/OFF switch (service-pin message)	o04*	-	-	-
Set supply voltage frequency	o12	50Hz (0)	60 Hz (1)	0
Select display view for the "normal display"				
1: Opening degree of the valve	o17	1	2	1
2: Superheat				
Manual control of outputs:				
0: Normal regulation	o18	0	1	0
1: Overriding. Manual control permitted				
Pressure transmitter selection				
1: AKS 32R / AKS 2050	o10	1	3	1
2: Pressure transmitter with 0-10 V				
3: Pressure transmitter with 1-5 V				
Working range for pressure transmitter Pc - min.	o20	-1 bar	5 bar	-1
Working range for pressure transmitter Pc - max.	o21	6 bar	199 bar	59
Refrigerant setting for P0 circuit				
1=R12. 2=R22. 3=R134a. 4=R502. 5=R717.				
6=R13. 7=R13b1. 8=R23. 9=R500. 10=R503.				
11=R114. 12=R142b. 13=User defined.				
14=R32. 15=R227. 16=R401A. 17=R507.				
18=R402A. 19=R404A. 20=R407C. 21=R407A.				
22=R407B. 23=R410A. 24=R170. 25=R290.				
26=R600. 27=R600a. 28=R744. 29=R1270.				
30=R417A. 31=R422A. 32=R413A. 33=R422D.				
34=R427A. 35=R438A				
Relay application: 0=Alarm relay. 1=EVR valve i liquid line	o36	0	1	0
Forced control of the valves opening degree. (Only if o18 is set to manual)	o45	0	100%	0
Working range for pressure transmitter P0 - min.	o47	-1 bar	5 bar	-1

Working range for pressure transmitter P0 - max.	048	6 bar	199 bar	12
Refrigerant for Pc circuit	----	0	35	28
Can only be changed via AKM / service tool				

Factory setting

If you need to return to the factory-set values, it can be done in this way:

- Cut out the supply voltage to the controller
- Keep both buttons depressed at the same time as you reconnect the supply voltage

Service		
Read status of input DI	u10	on/off
Temperature at S3 sensor	u12	°C
Temperature at S2 sensor	u20	°C
Read actual superheat SH	u21	K
Read actual superheat reference	u22	K
Read ETS valves opening degree	u24	%
Read pressure at pressure transmitter P0	u25	bar
Read P0 converted to temperature	u26	°C
Read calculated SH closing value	U19	K
Read Pc converted to temperature	U20	°C
Read pressure at pressure transmitter Pc	U21	bar

Connections

At opening degree: 10 V = 100% open valve
At signal to ICAD/ICMTS: 10 V = Open valve

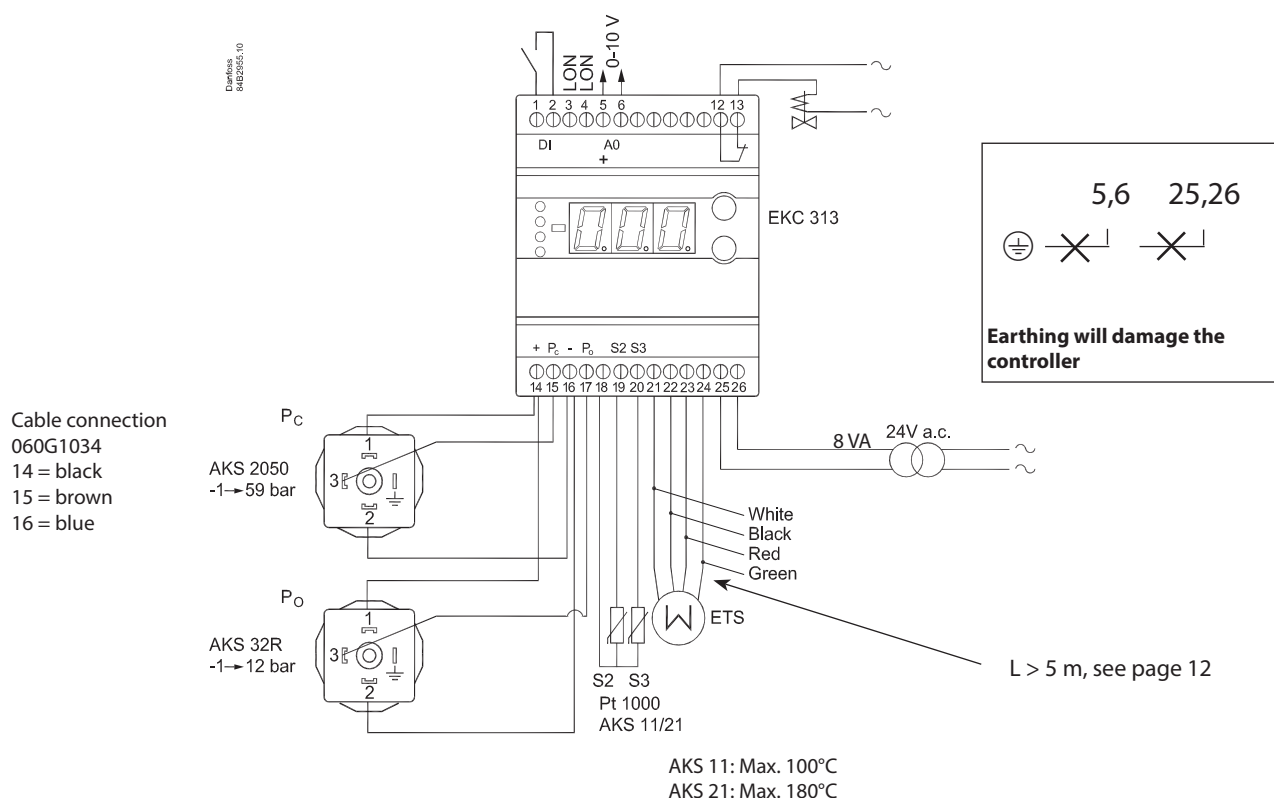

Necessary connections

Terminals:

- 25-26 Supply voltage 24 V a.c.
- 18-19 Pt 1000 sensor at the heat exchanger discharge on the cool side (S2)
- 18-20 Pt 1000 sensor at the heat exchanger input on the warm side (S3)
- 14,15,16 Type AKS 2050* pressure transmitter, -1 to 59 bar. Mounted at the heat exchanger's inlet on the warm side (P_c)
- 14,16,17 Type AKS 32R* pressure transmitter, -1 to 12 bar. Mounted at the heat exchanger discharge on the cold side (P_o)

Application dependent connections

Terminals:

- 1-2 DI input for external main switch (also see r12). If no switch is mounted, the terminals should be short circuited.
- 12-13 Relay for controlling solenoid valve in liquid line or the relay can be used as alarm relay (see o36).
Valve control: 12 and 13 are connected under normal operating conditions and interrupted supply voltage. Disconnects when regulation requires a low valve opening degree.
Alarm relay: 12 and 13 are connected in case of alarm.
- 21,22,23,24 Connecting an ETS valve. (Terminals 21 through 24 should not be used when using an ICMTS valve instead of an ETS valve. ICMTS valves should be controlled via the 0-10 V signal on terminals 5 and 6.)
- 5-6 Voltage output 0-10 V. Can be used for the valve's opening degree signal or to control an ICMTS valve. (For a special use with a solid state relay and AKV, the output will pulse with 10 V on/off)
- 3-4 Data communication
Mount only, if a data communication module has been mounted.
It is important that the installation of the data communication cable be done correctly. Cf. separate literature No. RC8AC...

*) For explosive applications an intrinsically safe pressure transmitter can be used. Connection is shown on page 12.

Data

Supply voltage	24 V a.c. +/-15% 50/60 Hz	
Power consumption	Controller	8 VA
Input signal	2 Pressure transmitter	Ratiometric, AKS 32R
		Ratiometric, AKS 2050 or 0-10 V / 1-5V
	Digital input from external contact function	
Sensor input	2 pcs. Pt 1000 ohm	
Alarm relay / solenoid valve relay	1 pcs. SPST	AC-1: 4 A (ohmic) AC-15: 3 A (inductive)
Actuator	ETS /CCM / CCMT	Step motor
	ICAD mounted on ICMTS	Voltage signal 0-10 V
Output signal	Voltage signal 0-10 V to either ICAD-control or to signal for valves opening degree	
Data communication	Possible to connect a data communication module type EKA 174	
Environments	-10 to +55°C, during operations	
	-40 to +70°C, during transport	
	20 - 80% Rh, not condensed	
	No shock influence / vibrations	
Enclosure	IP 20	
Weight	300 g	
Mounting	DIN rail	
Display	LED, 3 digits	
Terminals	max. 2.5 mm ² multicore	
Approvals	EMC acc. EN 61000-6-3 and EN 61000-4-(2-6, 8,11) LVD acc. EN 60730-1 and EN 60730-2-9	

NB

EKC 313 does not support valve type ETS 6.

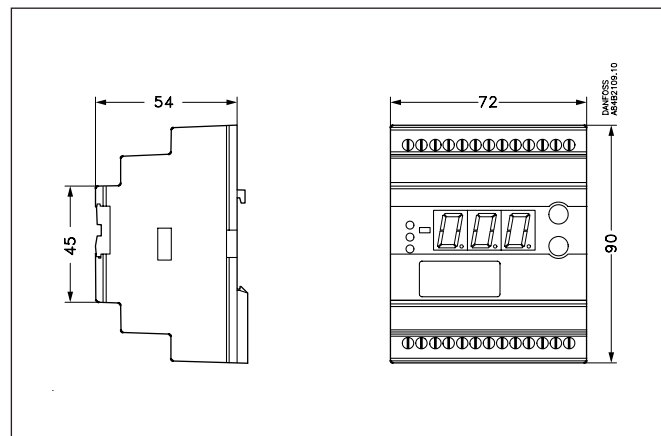

Ordering

Type	Function	Code no.
EKC 313	Cascade controller	084B7253
EKA 174	Data communication module (accessories), (RS 485 module) with galvanic separation	084B7124

Temperature sensor Pt 1000 ohm and pressure transmitter:
Kindly refer to catalogue RK0YG

ETS connection

If the distance between EKC 313 and the ETS valve exceeds 5 m a filter must be mounted to obtain the correct valve function.

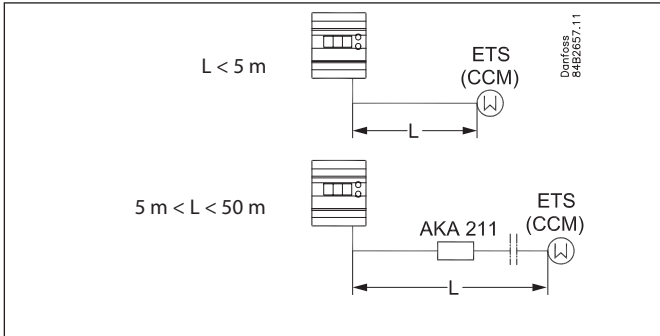

Connection

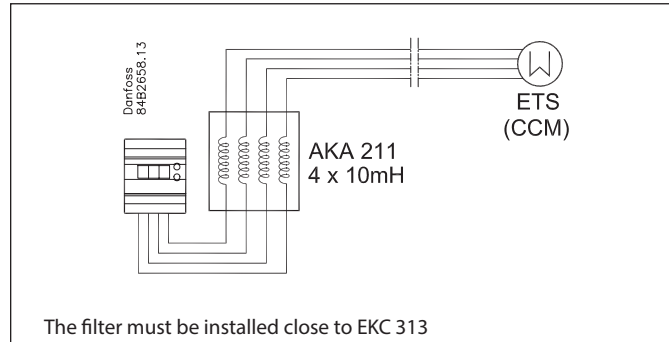

Dimensions

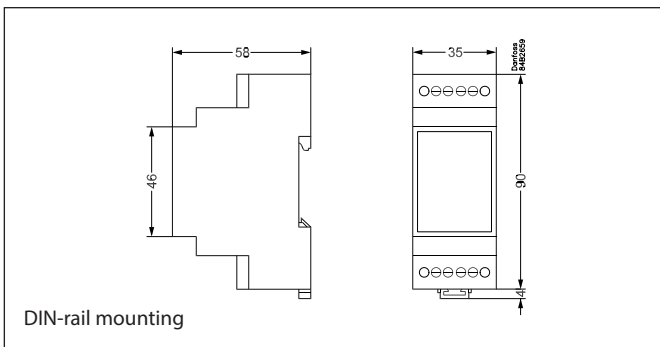

Ordering

Type	Description	Code no.
AKA 211	Filter 4 x 10 mH	084B2238

EX

Explosive application

Here the controller can receive a voltage signal of either 0-10 V or 1-5 V.
If the pressure transmitter supplies a current signal, a resistance of 250 ohm must be installed over the terminals.
The supply must be taken from the zener barrier.

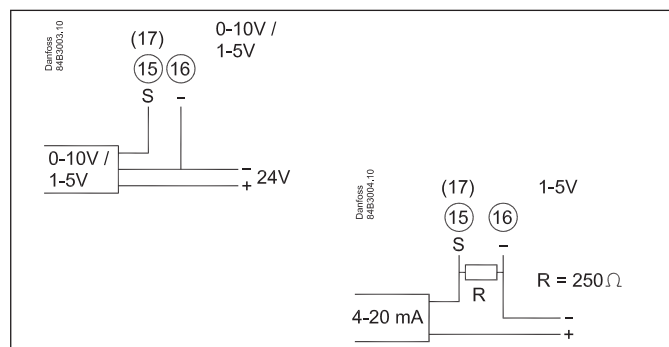

List of literature

- Instructions R18PB (extract from this manual).
Here you can see how controllers are mounted and programmed.
- Installation guide for extended operation RC8AC
Here you can see how a data communication connection to ADAP-KOOL® Refrigeration control systems can be established.

Installation considerations

Accidental damage, poor installation, or site conditions, can give rise to malfunctions of the control system, and ultimately lead to a plant breakdown.
Every possible safeguard is incorporated into our products to prevent this. However, a wrong installation, for example, could still present problems. Electronic controls are no substitute for normal, good engineering practice.
Danfoss will not be responsible for any goods, or plant components, damaged as a result of the above defects. It is the installer's responsibility to check the installation thoroughly, and to fit the necessary safety devices.