

ASC-18BI

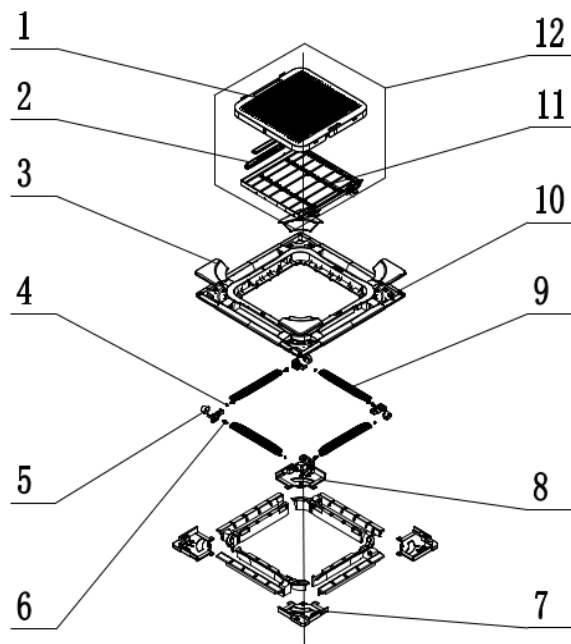
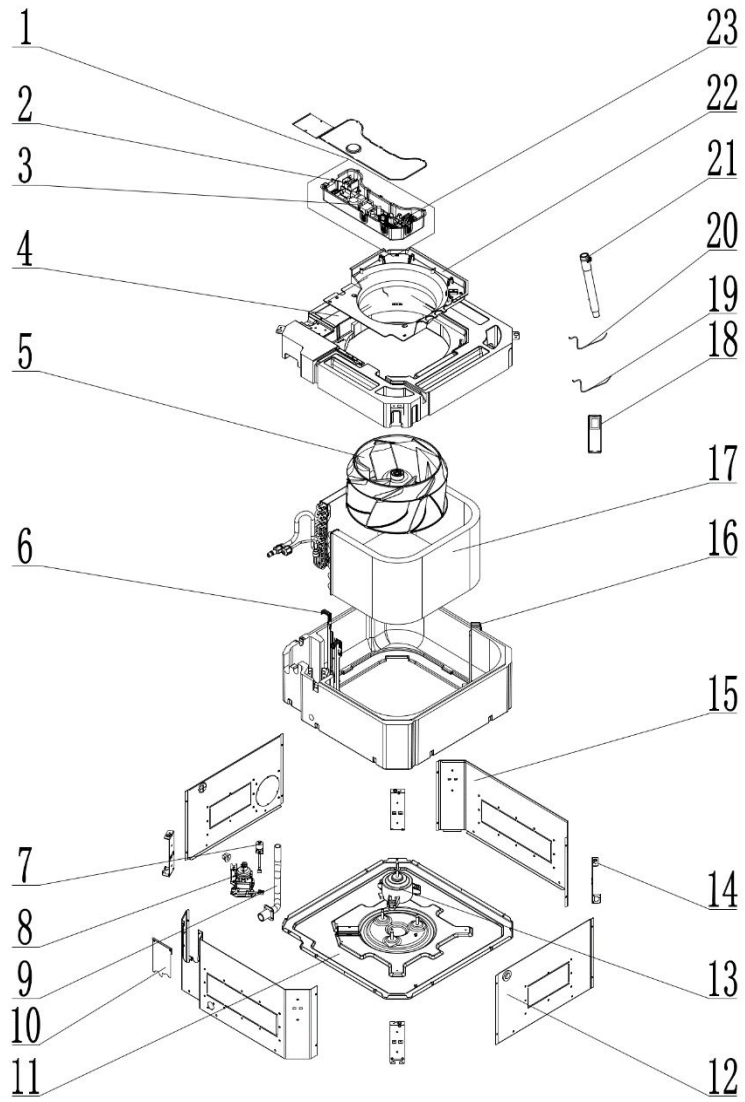

No	Description	Part Code	Note	Qty	Price Code
MODEL: ASC-18BI Cassette unit					
1	Electric Box Assy	100002003276		1	BA
2	Terminal Board	42011106		1	AD
3	Main Board	300002060465		1	AZ
4	Water Tray Assy	000069060065		1	AZ
5	Centifugal Fan	103003060008		1	AZ
6	Connection Sheet Sub-Assy	017025060047		1	AG
7	Liquid Level Switch	430024000005		1	AK
8	Water Pump	4313800005802		1	-
9	Drain Pipe	200070060005		1	AL
10	Sealplate	012034060119		1	AD
11	Seat Board Sub-Assy	017080060023		1	AS
12	Side Plate	012010060177		1	AH
13	Brushless DC Motor	150104060012		1	BC
14	Mounting Rack Sub-Assy	017044060011		4	AD
15	Side Plate	012010060175		1	AK
16	Support	012060061048		1	AC
17	Evaporator Assy	011001060299		1	BE
18	Remote Control	305001060024_L41419		1	-
19	Room Sensor	39000191		1	AD
20	Temperature Sensor	390001921		1	AD
21	Drain Hose Sub-Assy	007008000001		1	AG
22	Flow Guide Loop	200150060003		1	AF
23	Terminal Board	42018000551		1	AG
	Remote Holder	2615000701			
	Jumper	4202021902			
	Block Gasket	70413008			
	Nut	70310118			
	SWM-03 Wi-Fi Module (Optional)	5351100000626			
MODEL: ASC-18BI Cassette unit: PANEL					
1	Front Grill	27230012113		1	-
2	Display Board	300001060286		1	AK
3	Corner Cover Sub-assy	209066060003		4	AD
4	Left Axile Bush	10512037		4	AB
5	Step Motor	15729401		1	AG
6	Crankshaft	200023060001		4	AB
7	Corner Cover Sub-assy	209066060002		1	AD
8	Corner Cover Sub-assy	209066060001		3	AD
9	Guide Louver	200004060025		4	AC
10	Front Case	200002060020		1	AP
11	Filter Sub-Assy	111001060046		1	AD
12	Front Grill	209059060003_L41419		1	-

The data are subject to change without notice.