

Data sheet

Differential pressure controller (PN 25) AVP - return and flow mounting, adjustable setting

Description



AVP(-F) is a self-acting differential pressure controller primarily for use in district heating systems. The controller closes on rising differential pressure.

The controller has a control valve, an actuator with one control diaphragm and handle for differential pressure setting (fixed setting version (available on special request) is without handle).

Main data:

- DN 15-50
- k_{vs} 0.4-25 m³/h
- PN 25
- Setting range (AVP): 0.2-1.0 bar / 0.3-2.0 bar
- Fixed setting (AVP-F)¹⁾: 0.2 bar / 0.5 bar
- Temperature:
 - Circulation water / glycolic water up to 30%: 2 ... 150 °C
- Connections:
 - Ext. thread (weld-on, thread and flange tailpieces)
 - Flange

¹⁾ On special request

Ordering

Example 1:
Differential pressure controller;
return mounting; DN 15; k_{vs} 1.6;
PN 25; setting range 0.2-1.0 bar;
 T_{max} 150 °C; ext. thread

- 1x AVP DN 15 controller
Code No: **003H6283**
- 1x Impulse tube set AV, R 1/8
Code No: **003H6852**

Option:
- 1x Weld-on tailpieces
Code No: **003H6908**

The controller will be delivered completely assembled, inclusive impulse tube between valve and actuator. External impulse tube (AV) must be ordered separately.

AVP Controller (return mounting)

Picture	DN (mm)	k_{vs} (m ³ /h)	Connection	Δp setting range (bar)	Code No.	Δp setting range (bar)	Code No.	
	15	0.4	Cylindr. ext. thread acc. to ISO 228/1	0.2-1.0	003H6281	0.3-2.0	003H6291	
		1.0			003H6282		003H6292	
		1.6			003H6283		003H6293	
		2.5			003H6284		003H6294	
		4.0			003H6285		003H6295	
	20	6.3	G 1 A		003H6286		003H6296	
	25	8.0			G 1 1/4 A		003H6287	003H6297
	32	12.5			G 1 3/4 A		003H6288	-
	40	16			G 2 A		003H6289	-
	50	20			G 2 1/2 A		003H6290	-
	15	4.0	Flanges PN 25, acc. to EN 1092-2	003H6345	003H6351			
	20	6.3		003H6346	003H6352			
	25	8.0		003H6347	003H6353			
	32	12.5		003H6348	003H6354			
	40	20		003H6349	003H6355			
	50	25		003H6350	003H6356			

Note: other controllers available on special request.

Ordering (continuous)

Example 2 - AVP controller without predefined impulse tube:

Differential pressure controller; flow mounting; DN 15; k_{vs} 4.0; PN 25; setting range 0.2-1.0 bar; T_{max} 150°C; flange

- 1x AVP DN 15 controller
Code No: **003H6369**
- 2x Impulse tube set AV, R 1/8
Code No: **003H6852**

- Option:
- 1x Weld-on tailpieces
Code No: **003H6908**

The controller will be delivered completely assembled, without impulse tube between valve and actuator. External impulse tubes (AV) must be ordered separately.

AVP Controller (flow mounting)

Picture	DN (mm)	k_{vs} (m ³ /h)	Connection	Δp setting range (bar)	Code No.	Δp setting range (bar)	Code No.
	15	0.4	Cylindr. ext. thread acc. to ISO 228/1	0.2-1.0	0.2-1.0	0.3-2.0	003H6313
		1.0					003H6314
		1.6					003H6315
		2.5					003H6316
		4.0					003H6317
	20	6.3	G 1 A	003H6318			
	25	8.0	G 1 1/4 A	003H6319			
		15	4.0	Flanges PN 25, acc. to EN 1092-2			003H6369 ¹⁾
		20	6.3				003H6370 ¹⁾
25		8.0	003H6371 ¹⁾				
32		12.5	003H6372				
40		20	003H6373				
50	25	003H6374					

Note: other controllers available on special request.

¹⁾ Controller is without predefined impulse tube (see ordering example 2)

Accessories

Picture	Type designation	DN	Connection	Code No.
	Weld-on tailpieces	15	-	003H6908
		20		003H6909
		25		003H6910
		32		003H6911
		40		003H6912
		50		003H6913
	External thread tailpieces	15	Conical ext. thread acc. to EN 10226-1	R 1/2 003H6902
		20		R 3/4 003H6903
		25		R 1 003H6904
		32		R 1 1/4 003H6905
		40		R 1 1/2 065B2004
		50		R 2 065B2005
	Flange tailpieces	15	Flanges PN 25, acc. to EN 1092-2	003H6915
		20		003H6916
		25		003H6917
	Impulse tube set AV	Description: - 1x copper tube $\varnothing 6 \times 1 \times 1500$ mm - 1x compression fitting ¹⁾ for imp. tube connection to pipe $\varnothing 6 \times 1$ mm	R 1/8 003H6852	
			R 3/8 003H6853	
			R 1/2 003H6854	
			¹⁾ 10 compression fittings for imp. tube connection to pipe, $\varnothing 6 \times 1$ mm R 1/8 003H6857	
			¹⁾ 10 compression fittings for imp. tube connection to pipe, $\varnothing 6 \times 1$ mm R 3/8 003H6858	
			¹⁾ 10 compression fittings for imp. tube connection to pipe, $\varnothing 6 \times 1$ mm R 1/2 003H6859	
			¹⁾ 10 compression fittings for imp. tube connection to actuator, $\varnothing 6 \times 1$ mm G 1/8 003H6931	
	Shut off valve $\varnothing 6$ mm			003H0276

¹⁾ Compression fitting consists of a nipple, compression ring and nut.

Service kits

Picture	Type designation	DN (mm)	k_{vs} (m ³ /h)	Code No.	
				AVP return	AVP flow
	Valve insert	15	1.6	003H6863	003H6871
			2.5	003H6864	003H6872
			4.0	003H6865	003H6873
		20	6.3	003H6866	003H6874
		25	8	003H6867	003H6875
		32 / 40 / 50	12.5 / 20 / 25	003H6868	003H6876
	Type designation	Actuator with adjustable handle (AVP)	Δp setting range (bar)	AVP return	AVP flow
				0.2-1.0	003H6829
			0.3-2.0	003H6830	003H6835

Technical data

Valve

Nominal diameter		DN	15					20	25	32	40	50	
k_{VS} value		m ³ /h	0.4	1.0	1.6	2.5	4.0	6.3	8.0	12.5	20	25	
Cavitation factor z			≥ 0.6					≥ 0.55		≥ 0.5			
Leakage acc. to standard IEC 534	% of k_{VS}		≤ 0.02					≤ 0.05					
Nominal pressure		PN	25										
Max. differential pressure		bar	20					16					
Medium			Circulation water / glycolic water up to 30%										
Medium pH			Min. 7, max. 10										
Medium temperature		°C	2 ... 150										
Connections	valve	External thread											
		-					Flange						
	tailpieces	Weld-on and external thread											
			Flange					-					
Materials													
Valve body	thread		Red bronze CuSn5ZnPb (Rg5)					Ductile iron EN-GJS-400-18-LT (GGG 40.3)					
	flange		-					Ductile iron EN-GJS-400-18-LT (GGG 40.3)					
Valve seat			Stainless steel, mat. No. 1.4571										
Valve cone			Dezincing free brass CuZn36Pb2As										
Sealing			EPDM										
Pressure relieve system			Piston										

AVP Actuator

Type		AVP, AVP-F ¹⁾	
Actuator size	cm ²	54	
Nominal pressure	PN	25	
Diff. pressure setting ranges and spring colours	bar	0.2-1.0	0.3-2.0
		yellow	red
Materials			
Actuator housing	Upper casing of diaphragm	Stainless steel, mat. No.1.4301	
	Lower casing of diaphragm	Dezincing free brass CuZn36Pb2As	
Diaphragm		EPDM	
Impulse tube		Copper tube Ø6 × 1 mm	

¹⁾ On special request.

Application principles
- Return mounting

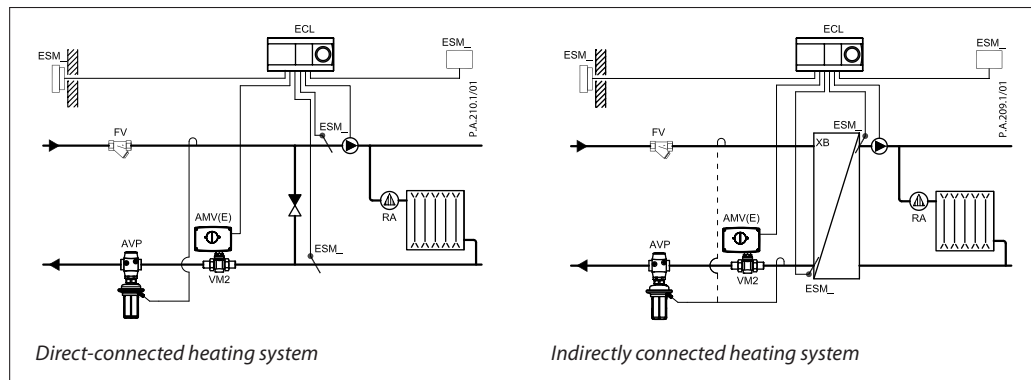

- Flow mounting

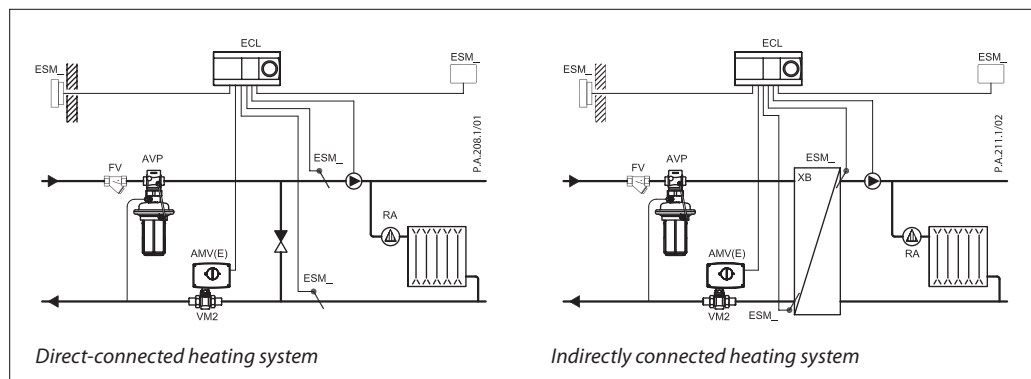

Installation positions

Up to medium temperature of 100 °C the controllers can be installed in any position.

For higher temperatures the controllers have to be installed in horizontal pipes only, with a pressure actuator oriented downwards.

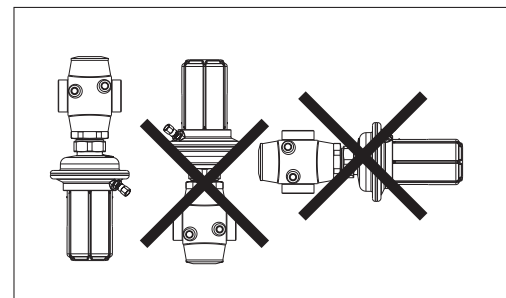
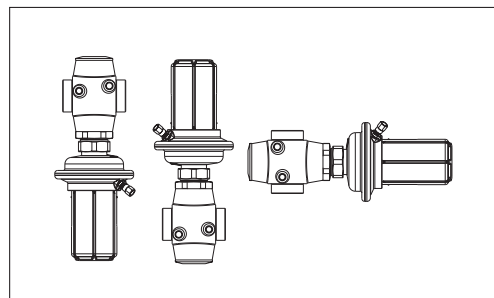

Pressure temperature diagram

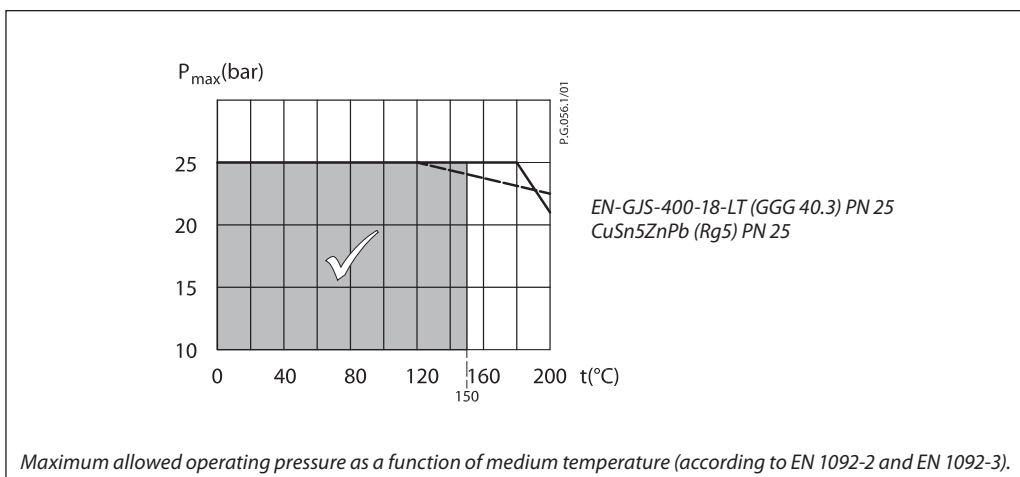

Sizing

- Directly connected heating system

Example 1

Motorised control valve (MCV) for mixing circuit in direct-connected heating system requires differential pressure of 0.3 bar (30 kPa).

Given data:

- Q_{max} = 1.2 m³/h (1200 l/h)
- Δp_{min} = 0.7 bar (70 kPa)
- * $\Delta p_{circuit}$ = 0.1 bar (10 kPa)
- Δp_{MCV} = 0.3 bar (30 kPa) selected

*Remark

$\Delta p_{circuit}$ corresponds to the required pump pressure in the heating circuit and is not to be considered when sizing the AVP.

The differential pressure set value is:

$$\Delta p_{set\ value} = \Delta p_{MCV}$$

$$\Delta p_{set\ value} = 0.3\ bar\ (30\ kPa)$$

The total pressure loss across the controller is:

$$\Delta p_{AVP} = \Delta p_{min} - \Delta p_{MCV} = 0.7 - 0.3$$

$$\Delta p_{AVP} = 0.4\ bar\ (40\ kPa)$$

Possible pipe pressure losses in tubes, shut-off fittings, heatmeters, etc. are not included.

k_v value is calculated according to formula:

$$k_v = \frac{Q_{max}}{\sqrt{\Delta p_{AVP}}} = \frac{1,2}{\sqrt{0,4}}$$

$$k_v = 1.9\ m^3/h$$

Solution:

The example selects AVP DN 15, k_{vS} value 2.5, with differential pressure setting range 0.2-1.0 bar.

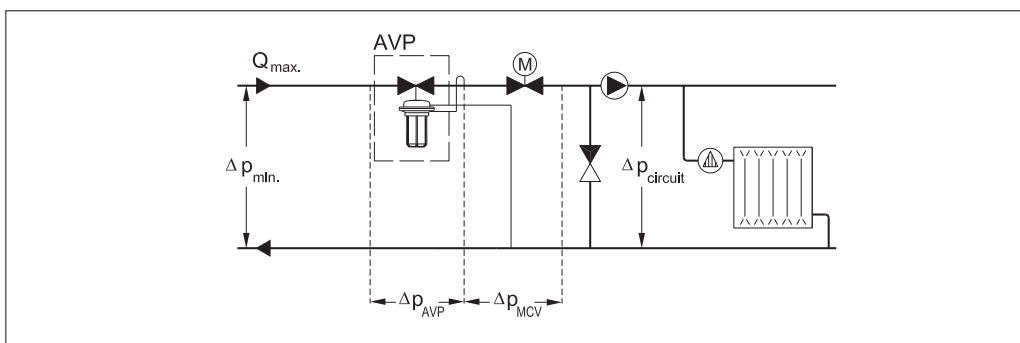
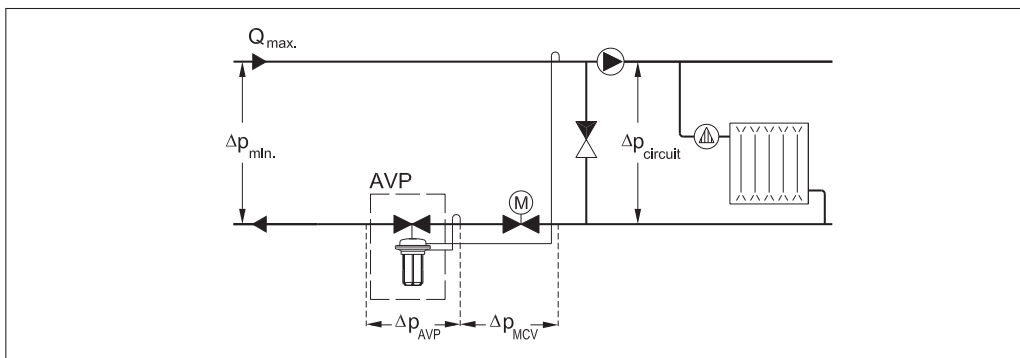

Sizing (*continuous*)

- Indirectly connected heating system

Example 2

Motorised control valve (MCV) for indirectly connected heating system requires differential pressure of 0.4 (40 kPa) bar.

Given data:

- $Q_{max} = 1.25 \text{ m}^3/\text{h}$ (1250 l/h)
- $\Delta p_{min} = 1.0 \text{ bar}$ (100 kPa)
- $\Delta p_{exchanger} = 0.05 \text{ bar}$ (5 kPa)
- $\Delta p_{MCV} = 0.4 \text{ bar}$ (40 kPa) selected

The differential pressure set value is:

$$\Delta p_{set \text{ value}} = \Delta p_{exchanger} + \Delta p_{MCV} = 0.05 + 0.4$$

$$\Delta p_{set \text{ value}} = 0.45 \text{ bar (45 kPa)}$$

The total pressure loss across the controller is:

$$\Delta p_{AVP} = \Delta p_{min} - \Delta p_{exchanger} - \Delta p_{MCV} = 1.0 - 0.05 - 0.4$$

$$\Delta p_{AVP} = 0.55 \text{ bar (55 kPa)}$$

Possible pipe pressure losses in tubes, shut-off fittings, heatmeters, etc. are not included.

k_v value is calculated according to formula:

$$k_v = \frac{Q_{max}}{\sqrt{\Delta p_{AVP}}} = \frac{1,25}{\sqrt{0,55}}$$

$$k_v = 1.7 \text{ m}^3/\text{h}$$

Solution:

The example selects AVP DN 15, k_{vs} value 2.5, with differential pressure setting range 0.2-1.0 bar.

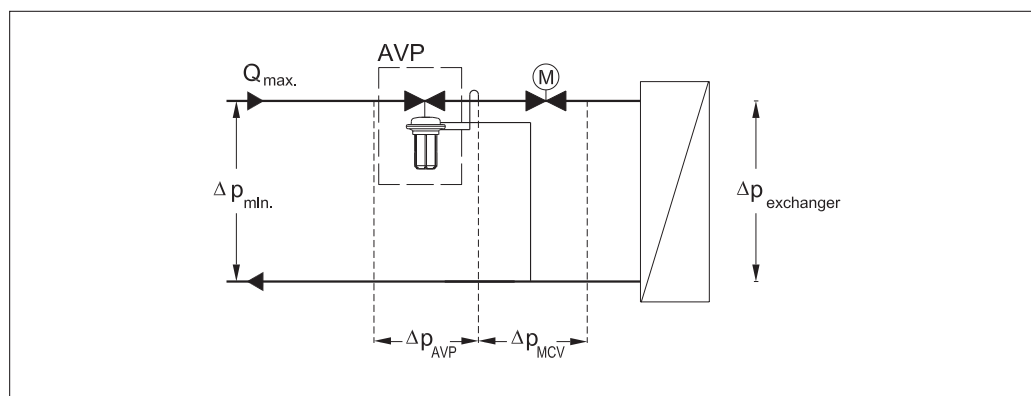
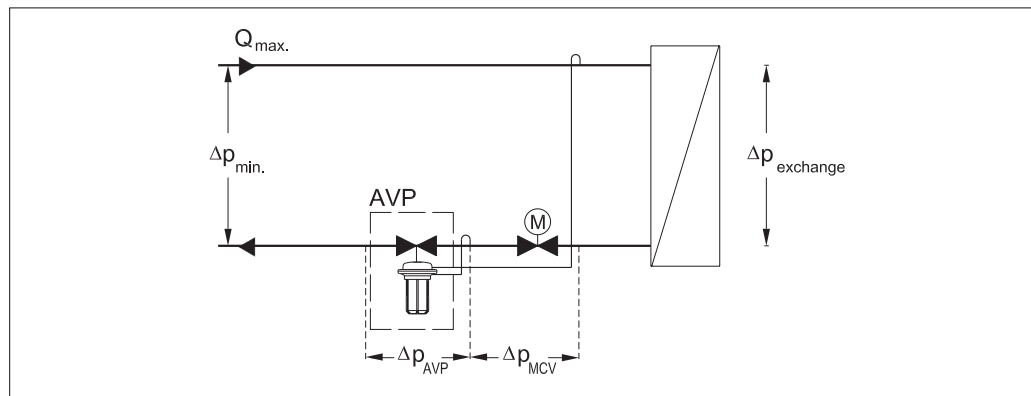

Design

- 1. Valve body
- 2. Valve insert
- 3. Pressure relieved valve cone
- 4. Valve stem
- 5. Control drain
- 6. Control diaphragm for diff. pressure control
- 7. Setting spring for diff. pressure control
- 8. Handle for diff. pressure setting, prepared for sealing
- 9. Union nut
- 10. Upper casing of diaphragm
- 11. Lower casing of diaphragm
- 12. Compression fitting for impulse tube
- 13. Excess pressure safety valve
- 14. Actuator

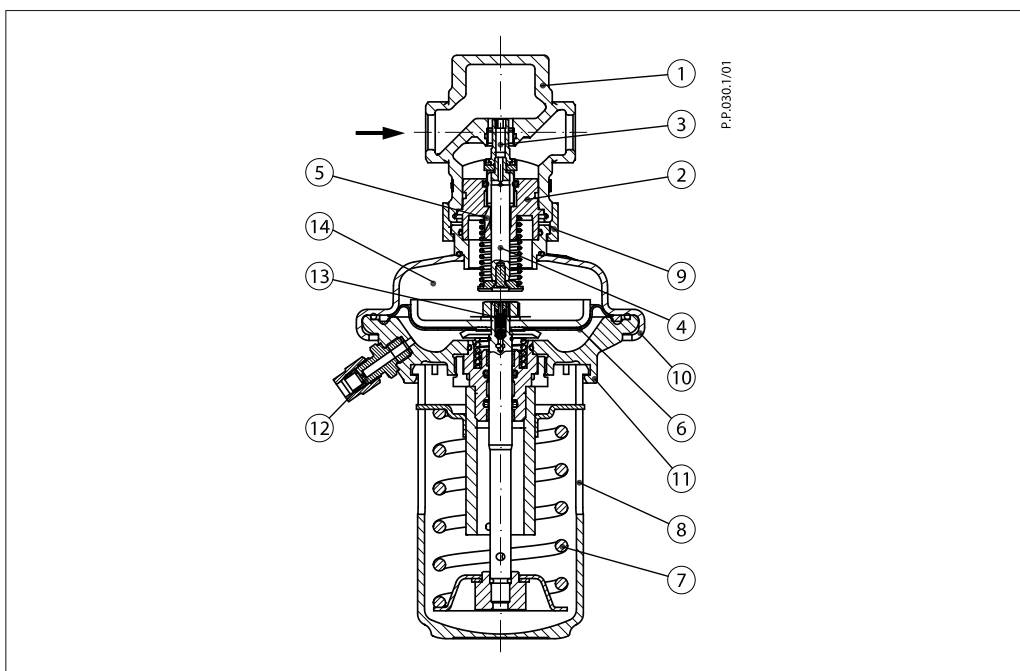

Function

Pressure changes from flow and return pipes are being transferred through the impulse tubes and/or control drain in the actuator stem to the actuator chambers and act on control diaphragm for diff. pressure control. The diff. pressure is controlled by means of setting spring for diff. pressure control. Control valve closes on rising differential pressure and opens on falling differential pressure to maintain constant differential pressure.

Controller is equipped with excess pressure safety valve, which protects control diaphragm for diff. pressure control from too high differential pressure (not implemented at AVP-F flow mounting version).

Settings

Differential pressure setting

Differential pressure setting (valid for AVP controller only) is being done by the adjustment of the setting spring for diff. pressure control. The adjustment can be done by means of handle for diff. pressure setting and/or pressure indicators.

Adjustment diagram

Relation between scale figures and differential pressure. Values given are approximate.

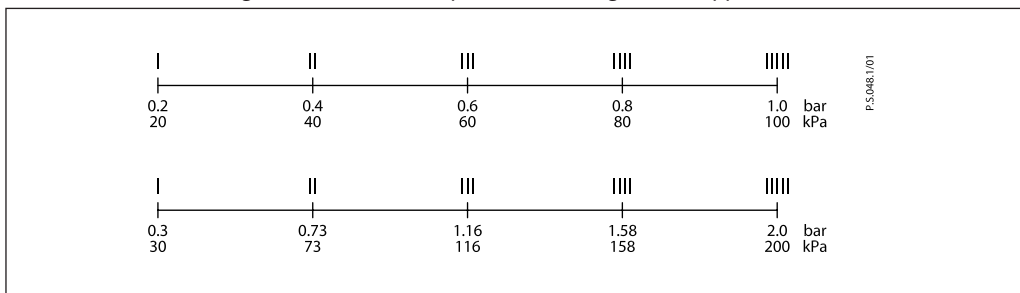

Data sheet

Differential pressure controller (PN 25) AVP

Dimensions

DN 15-50
DN 15-25
DN 32-50

DN	15		20		25		32		40		50	
	flow	return	flow	return	flow	return	flow	return	flow	return	flow	return
L	65		70		75		-	100	-	110	-	130
L ₁	130		150		160		180		200		230	
H	233		220		233		-		275		-	
H ₁	285		269		285		275		261		275	
H ₂	34		34		37		-		62		-	
H ₃	47		52		57		70		75		82	
Weight (thread)	3.5		3.5		3.7		-		5.8		-	
Weight (flange)	6.1		6.8		7.4		10.2		11.7		13.9	

Note: Other flange dimensions - see table for tailpieces.

DN	R ¹⁾	SW	d	L ₁ ²⁾	mm			k	d ₂	n
					L ₂	L ₃	k			
15	1/2	32 (G 3/4A)	21	130	120	139	65	14	4	
20	3/4	41 (G 1A)	26	150	131	154	75	14	4	
25	1	50 (G 1 1/4A)	33	160	145	159	85	14	4	
32	1 1/4	63 (G 1 3/4A)	42	-	177	184	100	18	4	
40	1 1/2	70 (G 2A)	47	-	200	204	110	18	4	
50	2	82 (G 2 1/2A)	60	-	244	234	125	18	4	

¹⁾ Conical ext. thread acc. to EN 10226-1
²⁾ Flanges PN 25, acc. to EN 1092-2

Compression fittings

R 1/8 / R 3/8 / R 1/2

Danfoss A/S

Climate Solutions • climatesolutions.danfoss.com • +45 7488 2222 • E-Mail: climatesolutions@danfoss.com

Any information, including, but not limited to information on selection of product, its application or use, product design, weight, dimensions, capacity or any other technical data in product manuals, catalogues descriptions, advertisements, etc. and whether made available in writing, orally, electronically, online or via download, shall be considered informative, and is only binding if and to the extent, explicit reference is made in a quotation or order confirmation. Danfoss cannot accept any responsibility for possible errors in catalogues, brochures, videos and other material. Danfoss reserves the right to alter its products without notice. This also applies to products ordered but not delivered provided that such alterations can be made without changes to form, fit or function of the product.

All trademarks in this material are property of Danfoss A/S or Danfoss group companies. Danfoss and the Danfoss logo are trademarks of Danfoss A/S. All rights reserved.